

# Freight- Supportive Guidelines





**Freight-Supportive Guidelines**

Ministry of Transportation

© Queen's Printer for Ontario, 2016.

**Disponible en français.**

All rights reserved. No part of this publication may be reproduced for commercial purposes without prior written permission of the copyright holder.

ISBN 978-1-4606-4675-5 (Print)

ISBN 978-1-4606-4676-2 (PDF)



# Table of Contents



<b>1.0</b>	<b>Introduction</b>	<b>1</b>
1.1	Purpose of the Guidelines .....	3
1.2	How to use the Guidelines.....	3
1.3	Benefits of Freight-Supportive Planning .....	6
1.4	Context.....	8
1.5	Freight Planning Integration .....	16
<b>2.0</b>	<b>Land Use and Transportation Planning Guidelines</b>	<b>19</b>
2.1	Freight Audit.....	21
2.2	Protecting Employment Areas and Freight Facilities .....	26
2.3	Planning for the Freight Movement Network.....	36
2.4	Improved Integration of Transportation and Land Use Planning.....	48
<b>3.0</b>	<b>Site Design Guidelines</b>	<b>57</b>
3.1	Site Design Elements Common to All Sites .....	59
3.2	Industrial Sites.....	65
3.3	Office Sites .....	68
3.4	Retail Sites .....	70
3.5	Residential Sites.....	74
3.6	Institutional Sites .....	76
3.7	Site Design to Support Freight Mobility in Existing Urbanized Areas.....	78
3.8	Site Design to Support Freight Movement in New Mixed-Use Areas.....	80
3.9	Site Design to Coordinate Freight Transportation with Public Transit, Cyclists and Pedestrians .....	81
3.10	Rural Sites .....	85

<b>4.0</b>	<b>Road Design and Operational Guidelines</b>	<b>87</b>
4.1	Access and Intersections.....	89
4.2	Corridors .....	103
4.3	Freight Gateways .....	112
4.4	Requirements, By-Laws, Policies, and Practice .....	117
<b>5.0</b>	<b>Implementation Strategies</b>	<b>125</b>
5.1	Recommended Actions .....	127
5.2	Implementation Tools.....	132
5.3	Infrastructure and Technology Investment and Funding Opportunities .....	137
5.4	Sample Checklist .....	139
<b>6.0</b>	<b>Case Studies</b>	<b>143</b>
6.1	Freight Audit Case Studies .....	145
6.2	Land Use and Transportation Planning Case Studies .....	151
6.3	Site Design Case Studies .....	159
6.4	Road Design and Operational Case Studies.....	161
<b>7.0</b>	<b>References</b>	<b>165</b>
7.1	Acknowledgements .....	167
7.2	Data References.....	168
7.3	Photo Credits .....	176
<b>8.0</b>	<b>Glossary and Index</b>	<b>185</b>
8.1	Glossary of Terms .....	187
8.2	Index.....	192

# 1.0 INTRODUCTION

---

A safe and efficient freight transportation system is important to the economic well-being of Ontario. The food we eat, the clothes we wear and items we use on a daily basis are all transported to our communities by road, rail, sea or air, and the goods we produce in Ontario start their journey on these transport networks. It also enables Ontario businesses to connect with North American and global markets. The freight transportation system relies on the same infrastructure that is used for moving people, and it is important to balance these competing interests when planning our communities and transportation systems. Creating communities that are supportive of freight movement is important to the sustainability of the economy, helping us maintain a high quality of life.







As communities change, through population and employment growth and intensification, it will become increasingly important to consider the needs of the freight movement industry. An efficient and effective freight movement network, integrated with developments that are supportive of freight, will help ensure that Ontarians have access to the goods and services that we rely on and will help support Ontario's economy. Efficient freight movement with appropriate facilities and infrastructure is a critical factor for Ontario and its municipalities to help attract new development and compete effectively with other jurisdictions.

### What is Freight Movement?

Freight movement is defined as the transportation of goods by road, rail, air, water and even pipeline. It includes: the movement of raw natural resources; the movement of refined goods for manufacturing, like steel, or auto parts; and the movement of finished products for markets like furniture or food products.

## 1.1 Purpose of the Guidelines

The purpose of the Guidelines is to help municipalities, planners, engineers, developers and other practitioners create safe, and efficient *freight-supportive* communities. By coordinating land use planning and freight mobility planning, the Guidelines help to respond to industry needs for freight movement in Ontario, as well as provide linkages between freight movement and land use planning policy and practice. The Guidelines include best practices, examples and implementation tools that are applicable to a wide range of communities and municipalities, and also provide direction for long-term, local implementation of *freight-supportive* policies and practices across Ontario.

In this context, the Guidelines are intended to:

- Provide direction for land use planning, site design practices and operational procedures that help with the movement of freight;
- Assist municipalities in understanding and planning for the various modes and types of vehicles used in the movement of freight; and
- Support the overall economic health and competitiveness of Ontario's municipalities.

The purpose of the Guidelines is to assist in the creation of communities, individual developments and transportation networks that are capable of supporting freight industries while integrating and balancing the compatibility of surrounding land uses and the needs of other *transportation system* users.

## 1.2 How to use the Guidelines

The Guidelines are intended to be used by municipal planners and civil engineers when updating or reviewing planning policy documents, reviewing development applications, or developing transportation plans. These Guidelines are applicable to both new development and redevelopment of existing areas.

The Guidelines represent advice to be used at the discretion of municipalities and do not represent formal statements of provincial policy. Implementation of the Guidelines is voluntary, and municipalities should evaluate their own freight needs and priorities to determine the appropriate guidelines and strategies required to address local circumstances. Where provincial plans and policies (e.g., Growth Plan and Provincial Policy Statement) apply, they may provide more specific direction.

The Guidelines have been organized as a manual to allow users to focus on specific guidelines applicable to land use and design scenarios. An interactive table of contents throughout the document helps users to focus on specific guidelines, and identifies complementary guidelines and related case study examples within each section.

### 1.2.1 Organization of the Guidelines

This introductory chapter provides background and context necessary to understand the complex role of freight movement along with the various modes available in Ontario. This background is intended to illustrate the transportation needs of the goods movement industry and demonstrates how freight movement may affect decisions related to transportation and land use planning as well as infrastructure investments.

The Guidelines provide a comprehensive set of strategies and direction for the implementation of *freight-supportive* planning measures in the areas of:

- Land use and transportation planning (Chapter 2);
- Site design (Chapter 3);
- Road design and operations (Chapter 4); and
- Implementation strategies (Chapter 5).

Chapter 6 provides case studies from other jurisdictions.

#### 1.2.1.1 Features and Navigation within the Guidelines

There are several features throughout this document that help to explain each guideline/strategy, and also help to direct the reader to additional information.

The strategies within the Guidelines are classified in five areas in order to indicate the appropriate location and resources required to implement the strategy. The five classification areas are:

**a**

- **Scope**
- **Settlement size**
- **Setting**
- **Required resources**
- **Land type**

The Complementary Guidelines feature allows the reader to switch back and forth between strategies located in other sections or other chapters that can be used together to help create *freight-supportive* communities.

In addition to the Complementary Guidelines feature, by clicking on the figure references within the text, the reader is taken directly to the corresponding figure.

Finally, the document includes text boxes in the side bar to draw the reader’s attention to additional information or resources related to the guideline or strategy that is being discussed.

An example of the features and navigation of the Guidelines is shown in **Figure 1.1**.



Figure 1.1: Example of guideline features and navigation

70 Freight-Supportive Guidelines

## 3.4 Retail Sites

### 3.4.1 Retail sites should balance truck access with access for other site users

Existing urban situations are discussed in more detail in Guideline 3.7.

Scope:	Settlement size:	Setting:
Site	All	All
<b>Required resources:</b> \$ - \$\$\$	<b>Land type:</b> 	

**Complementary Guidelines:**

- 2.2 Protecting Employment Areas and Freight Facilities, specifically Guidelines 2.2.4 and 2.2.5
- 2.4 Improved Integration of Transportation and Land Use Planning, specifically Guideline 2.4.1
- 4.1 Access and Intersections, specifically Guidelines 4.1.1, 4.1.2, 4.1.3, and 4.1.6
- 4.4 Requirements, By-Laws, Policies, and Practice, specifically Guideline 4.4.3

Retail sites, such as shops and restaurants, are found in all communities. They may be clustered in the centre of downtowns or at intersections in rural areas. For general retail sites, loading dock facilities are best located in the rear of these sites. Based on the available space, a designated loading area may be provided in front of the retail site. The retail site design should always consider the primary routes for customers arriving by foot, bike, automobile, or transit vehicle. Truck traffic should be routed in a way that facilitates access for trucks and customers.

**General Retail Strategies**

- a. Encourage truck deliveries to be made during off peak shopping and dining hours to facilitate better access for trucks and automobiles, transit, cyclists and *pedestrians*.
- b. Separate truck accesses from main *pedestrian*, cyclist and transit accesses.
- c. Design any on-site truck accesses to facilitate truck movement with sufficient cross-sections, lane widths and curb radii, and with direct connections from the main street network to the loading dock and delivery points.
- d. Loading docks should be located at the back of the building or on the side, away from the main road frontage and away from the main *pedestrian* entrance.
- e. Provide buffers in the form of landscaping, screens or walls to reduce the visual, noise and light impact from adjacent land uses (see [Figure 3.15](#)).

c

a

b

## 1.3 Benefits of Freight-Supportive Planning

These Guidelines recognize that sustainable freight systems make a positive contribution to the environmental, social and economic sustainability of the communities they serve. As such, elements of sustainability are integral to many of the guidelines and strategies in this document. These utilize proven techniques to improve freight mobility while reducing environmental and social impacts, and recognizing the importance of freight from an economic perspective.

The benefits of *freight-supportive* planning to Ontario's municipalities relate to the three pillars of sustainability: economy, society, and environment.

Freight movement plays a major role in the provincial economy, generating large revenues and supplying jobs for hundreds of thousands of employees. According to Transport Canada, in the year 2011, trade between Ontario and the United States amounted to over \$284 billion. 38% of Ontario's economy comes from freight-intensive industries. In that same year, Ontario led Canada in exports to countries other than the United States, with approximately \$40 billion in goods exported. Ontario's economy is multi-faceted, ranging from farming to manufacturing to 21st century knowledge economy businesses. All of these depend on the movement of freight in some way.

The location of industry is a function of a number of factors which are balanced against each other – proximity to raw materials, other related firms, population (markets), labour, capital, transportation infrastructure, the cost of land and municipal taxes. Efficient freight movement helps to support safe, livable and *complete communities*. Conflicts between trucks, trains, and *pedestrians*, cyclists, transit vehicles and private automobiles are minimized. *Sensitive land uses* such as residential areas, schools and hospitals are appropriately located, and either set away from freight movement facilities or buffered from them with landscaping, screens and walls.

The environmental benefits of efficient freight movement come from minimizing the amount of air pollution produced, minimizing the amount of fuel consumed and limiting the need for future transportation infrastructure investments. These benefits can be achieved through managing congestion and improving mobility, locating freight movement facilities with the "close to market" approach to reduce travel distances and optimizing the *transportation system* for efficient delivery of freight. Fuel efficiency is important to the freight industry because it directly impacts the bottom line. All of these efforts limit the environmental footprint of freight movement.

The value of freight transported in one year indicates the importance of freight movement to the Ontario economy. The freight movement industry needs a well-maintained infrastructure system and supportive land use policies to maintain and enhance this valuable industry. The continued success of the freight movement industry in Ontario reflects the tradition of maintaining and improving these *freight-supportive* factors.

### 1.3.1 Importance of Multimodal Supply Chains

Access to efficient multimodal supply chains is a deciding factor with respect to where a firm chooses to locate. While there are still many products that are quarried, grown, or harvested in Ontario and shipped to another region as a finished product, global supply chains are increasingly the norm. These supply chains are complex, with components for products being sourced from all over the world before being assembled and shipped to customers both at home and abroad.

Products rely on efficient transportation and use multiple modes. In general, high value-added, research-intensive sectors can have demanding transportation needs, with

components travelling longer distances under tighter timelines. As Ontario’s economy continues to attract high-value-added manufacturing and service jobs, the reliance on robust *multimodal transportation* networks and global supply chains will only increase.

The figures below show common global supply chains for Ontario products. A detailed supply chain view is illustrated for chocolate production. These supply chains require efficient transportation infrastructure and strong modal connections to operate effectively.

Figure 1.2: Chocolate production – detailed supply chain view

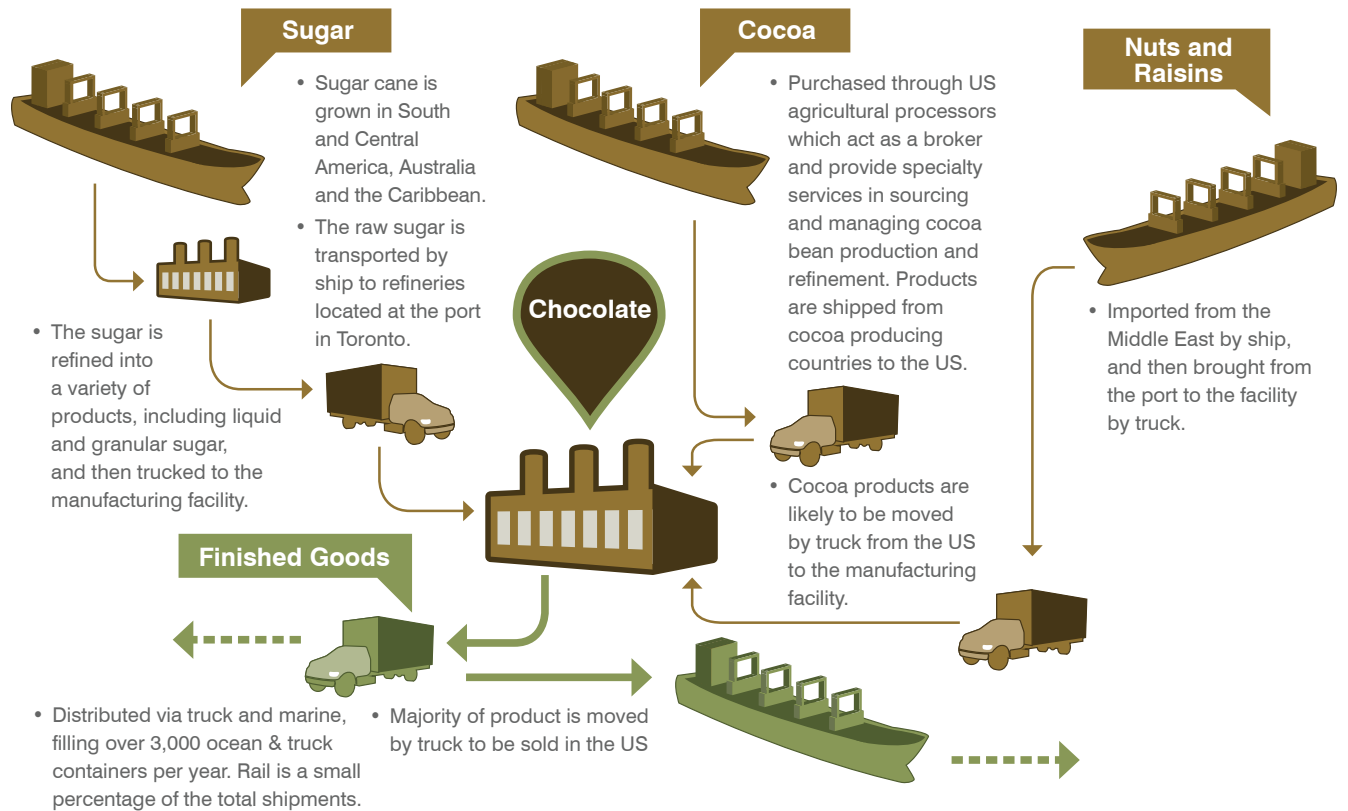

Figure 1.3: Common global supply chains for Ontario products

**Car Seat**



- 40 components sourced across 4 countries and 2 continents.
- Uses road, rail and marine modes.
- Requires 315 deliveries per week with deadlines as tight as 29 minutes.

**Lumber, Paper and Furniture**

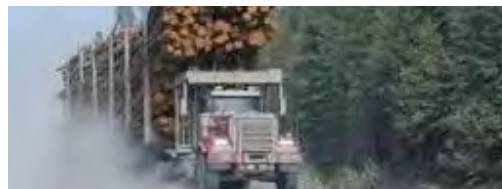

- Harvesting and initial processing in Northern Ontario
- Wood shipped by truck to Northern Ontario mills.
- Chemicals for pulp and paper moved by rail.
- Final products (paper, lumber, furniture) shipped throughout Canada and U.S. by rail and truck.
- International products moved by rail to ports of Montreal and Halifax, and then by ship to final markets.

**Copper**



- Mining and initial processing in Northern Ontario.
- Rail trip from mine to concentrator.
- Chemicals sourced from U.S. by rail and truck.
- Moved by rail to Quebec smelter.
- Finished copper shipped across North America (rail) and the world (marine) for use in other finished products.

## 1.4 Context

This section defines the context for freight movement planning in Ontario, in terms of:

- The planning context that supports freight movement;
- Introduction to *transportation systems* that support freight movement, by mode (road, rail, marine and air); and
- Freight movement trends.

### 1.4.1 Planning Context

Recent provincial planning initiatives, such as the Provincial Policy Statement (PPS), Growth Plan for the Greater Golden Horseshoe (Growth Plan) and the Growth Plan for Northern Ontario, support sustainable use of land by directing growth to *settlement areas* and discouraging growth in rural, prime agricultural and specialty crop areas. The transportation policies of these initiatives are implemented through various studies and plans, such as municipal official plans and transportation plans, and supported by publications, guidelines and studies prepared by the Ministry of Transportation.

Under the *Planning Act*, municipalities are required to revise and update their official plan every five years to ensure that it conforms with provincial plans, or does not conflict with them, has regard for matters of provincial interest and is consistent with the Provincial Policy Statement. The *Freight-Supportive Guidelines* are intended to complement and be in accordance with the existing provincial policy context by providing strategies, information and knowledge to assist municipalities in implementing *freight-supportive* policies in their official plans.

#### 1.4.1.1 Provincial Policy Statement (PPS)

All municipal official plans and decisions affecting a planning matter in Ontario are required to be consistent with the policies set out in the PPS. The PPS provides policy direction on matters of provincial interest related to land use planning and development, including providing specific direction on *freight-supportive* land use patterns, protection of *major goods movement facilities* and *corridors* and planning in the vicinity of *major facilities*.

#### 1.4.1.2 Official Plan

Official plans are high-level policy documents that:

- Set out the planning policy vision for the municipality;
- Guide how land is to be used; and
- Identify where and how growth and development will occur.

Municipalities should use official plans to establish policies that make the connection between transportation and land use. Often, municipalities use transportation master plans to complement or inform the official plan development process. The official plan can also be used as a tool to lay out a common vision to:

- Identify key transportation and freight networks;

- Identify appropriate land uses to support these networks;
- Coordinate public and private investments;
- Protect key transportation corridors and facilities from incompatible land use;
- Establish policies to measure and manage freight transportation needs; and
- Identify specific freight improvement projects that support the area’s economy by improving freight mobility.

#### 1.4.1.3 Other Supporting Tools, Guidelines, Plans, Legislation and Regulations

A number of other relevant guidelines and legislation provide some of the context for planning for *freight-supportive* communities and should be considered when planning for freight movement and freight industries. These guidelines and legislation include:

- The Metrolinx “Big Move” Regional Transportation Plan for the Greater Toronto and Hamilton Area;
- The Metrolinx GTHA Urban Freight Study (2011);
- Municipal zoning by-laws;
- Municipal Class Environment Assessment;
- Ontario Ministry of Environment and Climate Change’s Environmental Noise Guideline - Stationary and Transportation Sources;
- Vibration guidelines;
- D-Series Guidelines on land use compatibility;
- The Railway Association of Canada/Federation of Canadian Municipalities Guidelines for New Development in Proximity to Railway Operations; and
- The *Planning Act* and related regulations regarding notification to railways of land use changes adjacent to rail lines.

#### 1.4.2 Freight Movement Trends

The *transportation system* is used by a large number of shippers and many industries. Shippers and third party *logistics* providers make key decisions about the amount of goods to be shipped, where and when to move the goods, and which mode or service to utilize. In general, the decisions are based on finding a solution that minimizes the total cost of producing and shipping the goods, while meeting the levels of service, in terms of speed and reliability, which consumers demand.

##### **Global Supply Chains:**

Freight *transportation systems* have changed substantially over the past few decades. They must meet higher demands in service level, while maintaining competitive pricing, addressing issues associated with growth and congested road conditions.

##### **Just-In-Time Delivery:**

Global supply chains combined with integrated global production results in longer supply chains, with increased focus on service reliability. When considering logistic trends, it is

important to note that the use of rail, *intermodal* connections, ports, and air trade will continue to grow.

### Mobile Inventories and Demand-side Inventory Management:

“Just-in-time” delivery: businesses limit the amount of inventory on hand and rely on freight services to deliver the goods just in time

“Close to market”: locating distribution close to the markets they serve

Demand-side inventory management: ordering products from distribution centres to meet anticipated demand

New operating conditions imposed by changing economic, environmental and demographic practices have changed production, distribution and *logistics* requirements. An example of this is just-in-time delivery, where businesses limit the amount of inventory on hand and rely on freight services to deliver the goods that customers want “just-in-time.” This practice improves a business’s inventory cost by reducing transit times and reducing warehousing costs, while still providing the customer with the desired product.

Another example is demand-side inventory management, where online ordering results in mobile inventories as the normal business model in the freight movement industry. These changes have resulted in a significant increase in distribution and transportation centres, which are large warehouse structures, designed to accommodate and store high volumes of inventory with frequent movement of smaller loads. These centres are found in specific locations designed to serve regional markets. They require large tracts of land with easy access to higher order *transportation systems* and can generate significant amounts of truck traffic depending on the type of goods being stored. Some of these centres are being built on abandoned or underused industrial lands that are within the existing urban fabric. Re-using existing lands can benefit freight industries because of the close-to-market location of these *infill* sites.

These location requirements are resulting in clusters of truck activity along highway corridors and in large *employment areas* in urban areas. Just-in-time delivery and demand-side inventory management have led to frequent deliveries of goods and services. Understanding and adapting to trends in freight movement is important to maintain and grow freight industries while maintaining the quality-of-life of a municipality’s residents.

### 1.4.3 Introduction to Goods Movement in Ontario

Ontario’s *transportation system* is important to all sectors of the economy and to Canada’s overall economic health. Ontario has a complex and sophisticated *transportation system*, including Canada’s busiest highways, rail corridors, airports and border crossings, and it is also home to several significant ports and the Great Lakes marine system. Ontario’s *transportation system* and strategic location next to United States markets has made it a transportation hub for intra-provincial, national and international trade. Ontario’s highways and rail lines not only serve the needs of Ontario’s industries and employment sectors, but also increasing volumes of through traffic. This is also true for key airports, *intermodal* terminals and some ports that serve as national collection and redistribution points for goods.

Freight transportation is multimodal in Ontario. Four principal modes interact to deliver goods and services within and throughout the province, including roads (trucking), rail, marine, and air. The following paragraphs briefly describe the unique operating features of each of these modes, and identify their key facilities in Ontario. Some of the main facilities that support freight movement in Ontario are shown in [Figure 1.4](#).



Figure 1.4: Selected facilities that support freight movement in Ontario

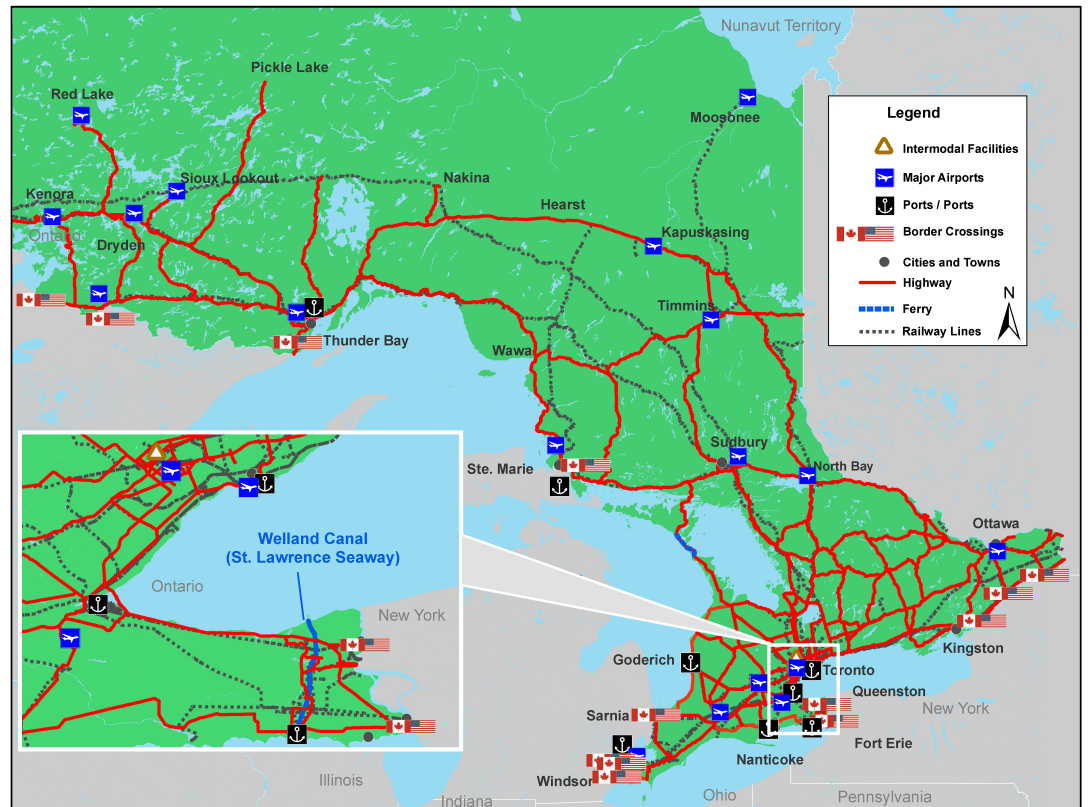

### 1.4.3.1 Roads

Trucking is used to transport a variety of goods. Examples of truck trips are provided to help illustrate the industry's diversity:

- High-value, small package freight generated from an on-line shopping order may travel by a company-owned small delivery truck from a courier depot at a major international airport to a local postal outlet in the same metropolitan area;
- Tankers haul products such as fuel and milk to communities across Ontario;
- Bulk agricultural products may be hauled several hundred kilometres from a field to a grain elevator by a farmer in a privately-owned transport trailer (i.e., single-trailer six-axle tractor semitrailer); and
- A for-hire carrier may make an inter-provincial trip hauling retail goods using a specially-permitted long combination vehicle (LCV).

Of the four freight transport modes, trucks offer the most geographically-specific freight delivery service from origin to destination. In addition to trips made exclusively by trucks, trucks are normally responsible for the “last mile” of trips in which other freight transport modes are used for the line-haul. Because of this, the trucking mode relies heavily on efficient connections with other freight modes at system facilities such as rail and marine *intermodal* terminals and airports. The trucking industry, which employs 200,000 people in Ontario, hauls 90% of consumer products and foodstuffs in the province. The amount of freight shipped on Ontario's roads is expected to grow.

In planning for future growth in the trucking industry, municipalities should be aware that increases in the number and size of trucks within communities and on roads will

The Ontario *Highway Traffic Act*, Section 16 defines a commercial motor vehicle, which for the purposes of this Guideline, will be described by the term “truck”, as any vehicle with a gross weight rating greater than 4,500 kilograms (though there are a few rare exceptions). The truck classification scheme shown in Table 1.1 has been used in these Guidelines. These classes describe trucks by trip type and also by geometric design requirements.

Table 1.1: Truck classification scheme

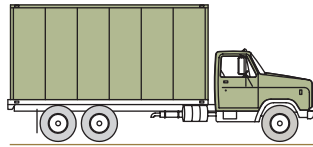

**Truck Class:**  
Single Unit (SU)

**Maximum Overall  
Vehicle Length:**  
12.5 m

- Used for small local deliveries
- Fixed connection between cab and body

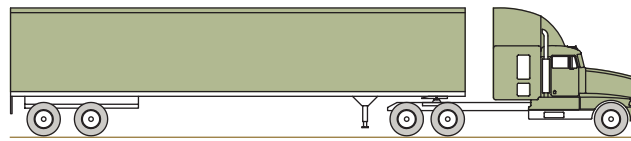

**Truck Class:**  
Single Semi Trailer (ST)

**Maximum Overall  
Vehicle Length:**  
23 m

- Most common articulated truck type
- Used for both long and short hauls

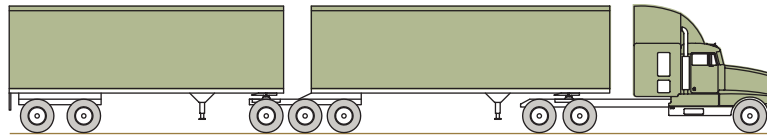

**Truck Class:**  
Double Trailer (D)

**Maximum Overall  
Vehicle Length:**  
25 m

- Used for long distance or heavy hauls

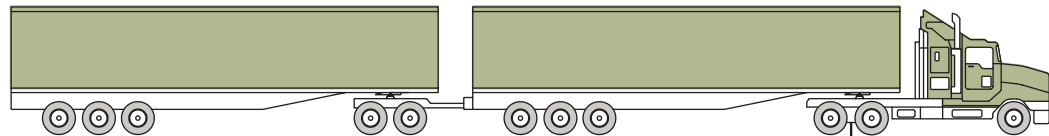

**Truck Class:**  
*Long Combination  
Vehicle (LCV)*

**Maximum Overall  
Vehicle Length:**  
40 m

- Has specific regulated requirements
- Restricted to approved routes
- Permitted to access origins and destinations about 2 km from the route, subject to municipal approval

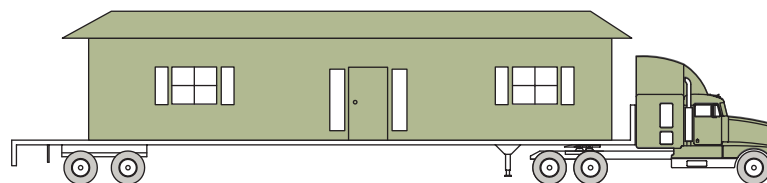

**Truck Class:**  
Oversize/Overweight  
(O/O)

**Maximum Overall  
Vehicle Length:**  
Varies

- Provide special freight movements which require a permit

result in an increase in the possibility of conflict between road users. For this reason, avoiding or reducing conflicts between various road users at intersections, and between transportation facilities and adjacent land uses continues to be an important part of land use planning.

### 1.4.3.2 Rail

The rail mode is mainly suited for hauling heavy, bulk commodities and *intermodal* containers over long distances, normally greater than about 650 kilometres. The rail mode is often used to move bulk shipments and other commodities to industrial facilities at *intermodal* terminals, port facilities and directly to and from industrial facilities that have rail sidings on site. Freight moved by rail is usually lower in value and is generally not time sensitive. However, rail transport can be used for higher value, time-sensitive freight such as finished automobiles, auto-parts, and consumer goods.

Figure 1.5: CN Brampton Intermodal Terminal



In Ontario, both Canadian National Railway (CN) and Canadian Pacific Railway (CP) operate mainline tracks, which service major freight hubs within the province and surrounding regions. CP owns and operates a transcontinental railway in Canada and the United States with direct links to eight major ports, including Vancouver and Montreal, extending its reach and allowing customers to access markets in every corner of the globe. CN offers an integrated North American rail network that serves Canada and 14 states, crossing the continent east-west and north-south - linking the Atlantic, Pacific and Gulf coasts to transport goods to a destination. Ontario also has a number of shortline and regional railways that operate on privately owned 'lower density' rail lines. Shortline and regional railways are an important component of Ontario's freight *transportation system* as they provide a direct link to the networks on branch lines connecting shippers to national, continental and international markets.

Railways under federal jurisdiction, including CN, CP and various smaller railways, are governed by the *Canada Transportation Act* and *Railway Safety Act*. Agreements with the federal government and agencies allow federal laws and powers, including safety regulations, to be applied to provincially-licensed railways. In planning for movement of goods by rail through communities, rail safety is a critical consideration. Municipalities can

Ontario has more kilometres of rail than any other province, with over 10,500 kilometres of rail lines.

support rail safety through planning decisions such as avoiding/reducing conflicts between various road users at road/rail crossings and between rail lines and adjacent land uses.

Key *intermodal* freight facilities within the Ontario rail network include:

CP *intermodal* facility in Vaughan (largest CP facility);

CN *intermodal* facility in Brampton (largest CN facility); and

Port of Thunder Bay, which is the largest outbound port on the Great Lakes St. Lawrence Seaway System.

Rail *intermodal facilities* are used to transfer goods between trains and other modes. Investments by rail operators in new track, equipment and other infrastructure improvements are increasing supply chain efficiencies. Additionally, the use of double stack rail flat cars, the use of longer trains coupled with distributed power, and the handling of containers at highly automated terminal facilities are developments aimed at increasing throughput capacity. Finally, increased transparency and improved communication and coordination will continue to improve supply chain performance.

### 1.4.3.3 Marine

Marine shipping is well suited to address the transportation needs of a variety of goods and sectors, ranging from aggregate resources to containers. The two main operational types of marine freight transportation are inland and ocean shipping. The majority of port deliveries are used on site, or transferred to rail. Deliveries are not always transferred immediately from marine to other modes and consequently there is a need to accommodate on-site storage. However, because of the types of cargo moved at ports, there can be a need to accommodate oversize and overweight movements for the local and regional road connections. Multimodal connections with the rail and road modes are important components of marine freight trips where the commodities are not used directly on site.

Marine transport accounts for almost 20,000 jobs in Ontario.

In Ontario, the major marine shipping corridor is the Great Lakes / St. Lawrence Seaway. The Seaway, which stretches from the Atlantic Ocean to Duluth, Minnesota on Lake Superior, handles a number of inland (short sea) trips with regional origins and destinations. Through the Seaway, Ontario's Great Lakes ports can provide a direct connection to overseas markets, either through direct end-to-end trips, or by transloading commodities to larger vessels in ports further up the St. Lawrence River or along the Atlantic coast. The Seaway services numerous ports in Canada and the United States, including important Ontario ports in Hamilton, Thunder Bay, Nanticoke, Port Colborne, Goderich, Windsor, and Toronto.

Planning and transportation needs will differ greatly depending on size of the port, volume of shipments and on-site operations. Looking to the future, a strong communication process between the local municipality and the port is critical for effectively planning for adjacent land uses and the surrounding transportation network that will support the economic activity at ports.

Figure 1.6: Port of Thunder Bay, Ontario



#### 1.4.3.4 Air

The air mode of transporting goods is the most ideal for high-value, and/or time-sensitive cargo such as courier shipments and perishables. Efficient connections at airports with the trucking mode of transport are an essential link for most freight trips by air. Traditional airfreight is highly concentrated in a few large airports. Two of the busiest Canadian airports by freight tonnage are located in Ontario, with Lester B. Pearson International Airport in Mississauga ranking first and the John C. Munro Hamilton International Airport in Hamilton ranking third. Other Ontario airports also play a role in providing specialized charter air freight service for specific commodities, and by providing freight service to remote regions without road access.

Air mode is used to move time-sensitive shipments to businesses that are higher in value and have a longer travel distance. Air requires the truck mode to transport the shipments to and from the airport; many of the truck types are smaller courier vehicles, however, tractor trailers can also be used. Most pick-ups and deliveries are time sensitive, and are less likely to have the scheduling flexibility to avoid travel during commuter peak periods is expected to grow significantly. In planning for transportation and land uses to support the airport facility, it is critical for municipalities to consider the impact on the municipal roads in terms of access to and from airports, especially as air cargo volumes increase and truck traffic increases to service the increased demand for freight delivered by air.

Over 450,000 tonnes of cargo was transported through Ontario airports in the year 2012, which represents 42% of all air cargo in Canada.

Figure 1.7: The FedEx facility at Lester B. Pearson International Airport in Toronto



## 1.5 Freight Planning Integration

Freight planning considerations need to be integrated into land use and transportation planning, site design and *transportation system* design, so that freight movements can occur safely and efficiently. Recognition of the existing freight movement patterns and trends, as discussed above, is critical to understanding how best to integrate freight into traditional land use and transportation planning.

### 1.5.1 Land Use and Transportation Planning

Coordinating and integrating land use planning with transportation planning is an important step in creating an efficient, competitive and sustainable community. *Transportation systems* provide the links for people and goods within a community and with neighbouring communities. Planning for freight is an important part of planning for *complete communities*. A well thought-out land use plan can improve *multimodal transportation* options by making trips shorter, decreasing traffic congestion, and lowering capital and maintenance costs for transportation infrastructure, as well as providing the opportunity for a healthier environment and a higher quality-of-life.

### 1.5.2 Site Design

Proper site design results in development of freight businesses, loading docks and delivery facilities that blend into the surrounding community and limit noise and air pollution. Integrating freight planning into site design includes:

- Appropriate site access points;
- Loading docks designed to accommodate the types of vehicles expected to use these facilities;
- Enough parking spaces, designed with appropriate dimensions and reserved for trucks. In urban settings with no on-site parking, on-street loading and unloading zones and truck-only parking spaces may be necessary to help with freight movement;
- Appropriate building placement on site, landscaping, noise mitigation and lighting; and
- Appropriate design of service lanes in strategic locations.

### 1.5.3 *Transportation Systems and Operations*

Operational planning and design ensures that *transportation systems* will be able to accommodate the full range of freight movement vehicles safely and efficiently, in harmony with other modes of transportation and in a way that reduces the impacts to the natural environment. Integrating freight planning into *transportation systems* and operations includes consideration for:

- Vehicle types and characteristics:
  - Truck size and weight; and
  - Increasing size of trains (both length and height with double stacking)
- Geometric design of roads and access points:

- Appropriate widths of travel lanes and turning lanes;
  - Turning lanes long enough to accommodate trucks;
  - Bridges designed to support the weight of trucks;
  - Adequate height clearance for trucks; and
  - Pavement design to support the loads of trucks.
- Access points, designed with appropriate curb radii and driveway width; and
  - Reliable travel time, through the provision of properly signed truck routes and real time information on any incidents along the truck routes.

#### 1.5.4 Stakeholder Collaboration

*Freight-supportive* planning benefits from collaboration with stakeholders. Principal stakeholders include:

- Federal, provincial, regional and local municipalities, which set the planning and transportation context for freight movement;
- Manufacturers, industries, farms, retail stores, offices and other trip generators that demand freight services for shipping and receiving freight;
- Freight facility operators (i.e., shippers, carriers, rail companies, airports, marine port authorities, airport authorities);
- Carriers (i.e., trucking companies, railways, airlines) that provide these services using a variety of modes; and
- Other stakeholders such as government regulatory agencies and third-party companies providing *logistics*, freight brokering and freight forwarding services.

Understanding the characteristics of freight demand within a municipality or region in terms of transportation mode, size, origin and destination, timing and trip frequency is important for proper public sector planning and engineering decisions. To promote progress toward common goals such as safety, productivity, and energy efficiency, there is a need to encourage coordination and dialogue between public sector officials, freight industry representatives and companies that are major shippers and receivers of freight deliveries.





## 2.0 LAND USE AND TRANSPORTATION PLANNING GUIDELINES

---

Freight considerations are an important part of planning for complete communities. The land use and transportation planning guidelines address how municipalities can become more freight-supportive through these planning processes, and balance the needs of freight movement with other municipal objectives. The following elements are addressed: protecting employment areas and freight facilities; planning for the freight movement network; and improved integration of transportation and land use planning.



## Legend

### Scope

Site

District

Municipal

Region

All

Applicable to all

### Settlement size



Small



Medium



Large

All

Applicable to all

### Setting



Rural



Urban

All

Applicable to all

### Required resources



Small



Medium



Large

All

Applicable to all

### Land type



Greenfield



Brownfield



Commercial



Residential

All

Applicable to all



Industrial



Mixed Use



Institutional



Denotes a strategy that supports fuel/energy efficiency or environmental protection.

## 2.1 Freight Audit

A *freight audit* is a planning and economic development tool used to assist municipalities, planners and engineers in making informed decisions to enable the safe and efficient movement of freight. By undertaking a *freight audit*, in coordination with a transportation master plan or an official plan update, municipalities will be in a better position to identify the appropriate tools to support freight and to develop *freight-supportive* communities. *Freight audit* case studies are described in Section 6.1.

### 2.1.1 What is a Freight Audit?

A *freight audit* is a background study that involves identifying where freight activities are generated or attracted (currently or in the future), operating constraints that affect freight levels of service (i.e., regulations, route restrictions, inadequate geometrics or loading standards), special considerations, and discussion with various stakeholders. Transit and the movement of people should be evaluated separately but planned for in a coordinated approach through the transportation master plan or official plan review.

### 2.1.2 The Need for Freight Audits

A *freight audit* is a proactive approach to freight transportation planning, which will help municipalities consider the local needs and priorities associated with the movement of freight in land use planning, site design and infrastructure investments. The role of the *freight audit* is to identify issues affecting local freight movements and to provide the baseline information to help establish planning and infrastructure priorities needed to support the safe and efficient movement of freight.

### 2.1.3 Freight Audit Phases

A *freight audit* involves four phases: set-up, data collection, analysis, and communication.

### 2.1.4 Phase 1: Set-up

The set-up phase includes three major activities including problem definition, identification of staff and financial resources, and project planning (i.e., identification of the information to be collected and analyzed). The scope of the audit should be compatible with the available resources. The amount of information needed to be collected in a *freight audit* will be a function of the size of a community, whether a freight issue exists that requires resolution

---

#### What is a freight audit?

A planning and economic development tool used to assist municipalities, planners and engineers in making informed decisions to enable the safe and efficient movement of freight.

---

#### What are the objectives of a freight audit?

Identification of:

- Locations where freight activities are generated or attracted (currently or in the future)
- Operating constraints

Stakeholder dialogue

---

#### Why is a freight audit needed?

- To identify issues affecting local freight movements
- To help establish priorities to support the safe and efficient movement of freight

---

#### Phases of a Freight Audit

1. Set-up
2. Data collection and Management
3. Analysis
4. Communication

and how much data is needed to address and solve the problem. *Freight audit* case studies are described in Section 6.1.

#### 2.1.4.1 Project Planning

##### Goal of Project Planning

Identify the type of information to collect for analysis and how the information is going to be collected.

Identify the type of information to collect for analysis and how the information is going to be collected based on the staff and financial resources dedicated to the project. Key information to collect as part of the *freight audit* may include:

1. *Major goods movement facilities and corridors*, including:
  - a. *Employment areas* by type and location (to identify clusters); and
  - b. Employment uses, including manufacturing, warehousing and storage facilities in industrial areas, primary uses (i.e., forestry, aggregate producers), retail shopping uses, commercial office buildings, institutional buildings and mixed use developments, rail yards, airports and marine ports.
2. Principal freight corridors and secondary feeder routes, including traffic volumes and patterns;
3. Contribution by the freight industry to the local economy;
4. Traffic activity by the mode(s) of interest (e.g., truck traffic, rail traffic);
5. Route constraints (i.e., geometric considerations at selected intersections, signal timings, speed limits, vehicle exclusions, size of laneways);
6. Operating constraints (e.g., insufficient loading areas, time of day restrictions, street furniture);
7. Other relevant factors of interest to the public (i.e., reduction of noise, vibrations and emissions, hazardous freight and exceptional load movement);
8. Applicable regulations (i.e., truck size, weight, and safety regulations);
9. Enforcement practices, including ticketing violations and compliance rates; and
10. Areas of conflict.

Not all elements need to be considered in all audits. Determining the information to collect and analyze, the method of collection, and stakeholder engagement strategy should be part of the project planning phase and should be based on the established scope and resources available for the *freight audit*.

## 2.1.5 Phase 2: Data Collection and Management

The data collection phase can involve a variety of steps depending on the scope of the audit, such as quantitative data collection, intelligence gathering and stakeholder consultation, and site visits. In a smaller municipality with less extensive freight needs, an audit could focus largely on discussions with other municipal departments and freight stakeholders. A municipality with more complex freight needs may choose to invest in more detailed studies and quantitative analysis to support the audit.

### 2.1.5.1 Quantitative Data Collection

In addition to the information identified for collection discussed in section 2.1.4.1, basic information about freight volumes and trends should be collected as part of a more detailed *freight audit*. In the case of freight movements by truck, useful freight data **could** include:

1. Traffic volumes by vehicle class on major roads or key freight corridors:
  - a. 24-hour Automatic Traffic Recorder count programs for a complete knowledge of the hourly distribution of the types of trucks; and
  - b. Traffic classification count programs (which many municipalities already conduct), including a count of multiple truck classes.
2. Freight movements by economic sector, including origins, and destinations.
3. Land use in terms of freight generators and attractors.

---

#### Quantitative Data Collection:

Information related to freight volumes and trends should be collected.

### 2.1.5.2 Intelligence Gathering and Stakeholder Consultation

Stakeholder consultation is important for identifying the characteristics of freight in a municipality as well as the critical transportation and land use issues affecting freight. Stakeholder consultations should consist of at least two components:

1. **Stakeholder Survey:** information gathering/survey of key freight generating facilities. Questions included in the survey should address:
  - Number of trucks into and out of a facility, ideally by time of day and day of week;
  - Key truck access/exit routes to a facility, and issues along those routes;
  - Operational issues and concerns; and
  - Plans for expansion (if possible).

---

#### Stakeholder consultations should consist of two or more components:

A stakeholder survey and workshops/public meetings.

2. **Workshop or Public Meeting:** General freight stakeholder consultation to identify freight transportation issues, through a symposium or workshop for stakeholders.

### Site Visits

Visiting freight-intensive areas is important in order to obtain additional information about physical infrastructure and freight needs. Site visits should be used to identify:

- Entering and exiting truck volumes from major transportation facilities during peak trucking hours;
- Areas of conflict;
- High volume trucking routes; and
- Transport mode interaction issues identified in stakeholder consultation (i.e., grade separations).

## 2.1.6 Phase 3: Analysis

### Freight Facilities: Supply and Demand

By identifying where the demand for freight service is located (i.e., *employment areas*, employment uses, commercial or mixed use areas and truck traffic), municipalities can analyze the supply of facilities and infrastructure to serve the freight industry and recommend any necessary adjustments.

Data collected for this part of the audit can be mapped in GIS to show the location of:

- Freight assets (nodes and freight centres);
- Freight corridors (haul routes - formal);
- Special facilities such as warehouses, rail yards, *intermodal* centres, ports and airports; and
- Planned infrastructure investments.

### Infrastructure

Analysis of existing infrastructure should consider the strengths and weaknesses of the *transportation system*, and should include consideration for developing a strategic freight or truck route network (see [Guideline 2.3.1](#)):

- The adequacy of infrastructure supporting freight movement (from a capacity and geometric perspective) including identification of priority projects to address identified issues.

### Applicable Policies, Regulations and By-Laws

When carrying out a *freight audit*, it is important to also understand the policies, regulations, and by-laws of both internal and neighbouring jurisdictions or municipalities. In many cases, the

---

#### Employment areas:

Areas designated in an official plan for clusters of businesses and economic activities including, but not limited to, manufacturing, warehousing, and offices.

---

By mapping the supply and demand for freight, the freight infrastructure can be further analyzed to identify where infrastructure is lacking and to recommend areas for further investment or policy changes to support freight movements.

regulations in other jurisdictions have an effect on what takes place in surrounding jurisdictions. Examples include:

- Special seasonal allowances and restrictions, and how they are applied;
- Requirements for overweight/over dimension movements;
- Policies/processes that address freight movement needs and issues such as:
  - A review of area by-laws; and
  - A review of restrictions to the safe and efficient movement of freight with an action plan (identified through the capital budgeting process) to address those impediments (i.e., changes to traffic signalling).

### Enforcement Practices

Enforcement practices and violation trends in a municipality are important considerations to document during the *freight audit*. While enforcement and violation issues may be viewed as negative towards freight, it is important to identify these issues in order to find appropriate solutions that are *freight-supportive*. Elements of interest, especially relating to freight movements by truck, include:

- Intensity of enforcement; and
- Intensity of violations.

This information is needed to better understand potential problems and to identify possible solutions. Stakeholders and the public can help to identify areas where conflicts may occur between freight and other road users or land uses.

## 2.1.7 Phase 4: Communication

Following the collection of detailed data and analysis, the *freight audit* report and presentation should provide direction for identifying the guidelines that should be considered or implemented to support freight, and can help identify priority areas for improvement.

### 2.1.7.1 Final Report

The *freight audit* report should outline the information gathered during the data collection process, any quantitative analysis, and observations obtained from the analysis, as well as a summary of input received from stakeholder consultation. The report should identify deficiencies in the existing infrastructure and *transportation system*, policies or by-laws and should also present opportunities and recommendations for improvement.

---

It is important to understand local policies, regulations, by-laws, enforcement and violation trends in the preparation of a *freight audit*.

---

The *freight audit* report should identify implementable actions to support safe and efficient freight movement.

## 2.2 Protecting Employment Areas and Freight Facilities

### 2.2.1 Consider freight movement needs through long-range planning

#### Complete communities:

*Complete communities* meet people's needs for daily living throughout an entire lifetime by providing convenient access to an appropriate mix of jobs, local services, a full range of housing, and community infrastructure including affordable housing, schools, recreation and open space for their residents. Convenient access to public transportation and options for safe, non-motorized travel is also provided.

It is very important for municipalities to consider freight when undertaking new long-range planning exercises, such as when undertaking a new or updated official plan, secondary plan, transportation master plan, or zoning by-law drafting or review. Incorporating freight into planning documents is part of planning for *complete communities*. For example, truck routes have been established by numerous municipalities as a means to reduce traffic congestion and conflict, help trucks avoid using inappropriate streets and provide an operating environment that improves *logistics* efficiencies and the economic competitiveness of land areas and municipalities.

Consider establishing links between the freight movement needs and that of the future or existing *employment areas* as identified in local planning documents. The *freight audit*, as discussed in Section 2.1 should be undertaken as a component of the long-range planning within a municipality.

#### Strategies

<b>Scope:</b>	<b>Settlement size:</b>	<b>Setting:</b>
Municipal and Region	All	All
<b>Required resources:</b>	<b>Land type:</b>	
\$	All	

- Undertake a *freight audit* to identify and assess demand for freight infrastructure and to make necessary improvements to freight infrastructure.
- Include a policy section in the municipal official plan, transportation master plan or secondary plan that provides support and direction for local freight movement.
- Provisions should be included in the local zoning by-law, including setbacks, loading zones, ingress and egress to support the needs of the freight movement industry.



### 2.2.2 Identify and protect all *major goods movement facilities and corridors* within and between neighbouring jurisdictions

As more freight is shipped via truck and rail transport, it is increasingly important to ensure that the existing infrastructure is maintained and enhanced, and that future freight corridors and *adjacent lands* are protected. Inter-regional level *truck routes/corridors* are key links in providing connections to and from communities and provincial highways, and also play a key role in serving many businesses with just-in-time delivery and door-to-door services.

Establishing priority routes for freight movement, to facilitate the movement of freight into and out of areas of significant employment, industrial and commercial activity and to provide alternative routes connecting to the provincial network will support efforts for efficient freight movement.

The location of employment nodes, freight transfer facilities (i.e., railway *intermodal* yards, airports and major ports) in adjacent municipalities along with connecting corridors and freight volumes passing through the regions should be identified in this process.

Figure 2.1: Freight nodes and corridors

It is important to identify the primary truck routes and nodes to understand where corridors should be protected for freight movement.

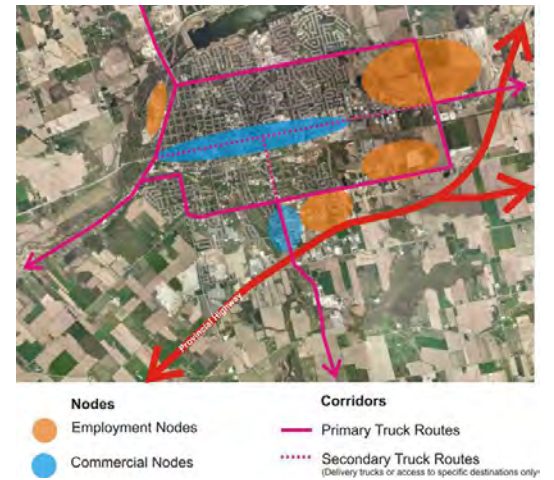

Figure 2.2: New employment areas in one jurisdiction may require road improvements in another jurisdiction

It is important to maintain cooperation between different jurisdictions as an element in freight movement.

## Strategies

<b>Scope:</b>	<b>Settlement size:</b>	<b>Setting:</b>
Municipal and Region	All	All
<b>Required resources:</b>	<b>Land type:</b>	
<b>\$</b>	All	

### Complementary Guidelines:

- 3.10 Rural Sites
- 4.1 Access and Intersections
- 4.2 Corridors, specifically Guideline 4.2.1
- 4.3 Freight Gateways
- 4.4 Requirements, By-Laws, Policies, and Practice

- a. Identify and protect existing and planned freight corridors and facilities in planning documents (official plans, transportation master plans, zoning by-laws etc.) to enhance the efficiency and quality of these routes.
- b. Prepare consistent and coordinated mapping of all major freight facilities (i.e., border crossings, rail corridors, harbours, *intermodal facilities*, major distribution centres, *employment areas* etc.) and truck routes/corridors within jurisdictional/municipal boundaries. Include information in a Geographic Information System (GIS) layer and official plan / zoning by-law schedules.
- c. Protect industrial and/or commercial lands located near identified freight corridors to allow for future freight movement industries to utilize this land use.
- d. Establish priority routes for freight movement, where feasible, to facilitate the movement of goods into and out of significant employment, industrial and commercial facilities.
- e. Collaborate with neighbouring municipalities and freight stakeholders.
- f. Discuss possible changes to local freight facilities and corridors or major trucking destinations with freight stakeholders and neighbouring municipalities to receive input and ensure plans are kept up-to-date, and to allow for coordinated infrastructure investments where possible.
- g. Coordinate major changes to inter-regional and international routes that affect neighbouring municipalities, identify new routes and agree on them before the projects that rely on the change are approved. This can be undertaken as part of a Class Environmental Study or within review periods of official plans or transportation plans.
- h. Consider freight needs of all sites and identify uses that are freight-intensive.

### 2.2.3 Identify areas for new freight facilities and *freight-intensive land uses* and plan for future freight corridors

Municipalities should develop strategies for identifying and updating potential new freight attractors and generators, such as new or expanded *employment areas*, new factories, new major commercial areas, potential quarries or landfill sites, or new freight distribution facilities. This will help to ensure that freight routes/corridors are protected and that consideration of the location of existing employment nodes and future nodes outside of municipal borders have been undertaken.

In addition, when developing and designing new municipal roadways, consideration should also be given to the minimum standards that need to be met, as outlined in Chapter 4.0 (Road Design and Operational Guidelines), which should be read in accordance with the minimum standard set out by the municipality in the local official plan and zoning by-law.

#### Strategies

- a. Collect relevant data and map all major planned growth areas, and in particular planned *employment areas* and major freight facilities, to ensure future freight corridor needs can be met.
- b. Identify future multimodal locations, rail transfer yards and container terminals, airports, and expansion of existing facilities.
- c. Identify where new freight movement generators and attractors are being located to ensure that the new generators are linked to broader freight movement networks.
- d. Establish priority routes for the efficient movement of freight into and out of areas with significant employment, industrial and commercial activity.
- e. Consider the geometric requirements of *Long Combination Vehicles* for road design for connecting roads to any freight-intensive employment land within 2 km of a 400-series highway. See [Guideline 4.1.6](#) and [4.2.1](#).
- f. Coordinate with neighbouring municipalities.
- g. Protect lands adjacent to *major goods movement facilities and corridors for freight-intensive land uses*.
- h. Direct new *freight-intensive land uses* to areas well-served by major highways, airports, rail and *marine facilities*.

<b>Scope:</b>	<b>Settlement size:</b>	<b>Setting:</b>
Municipal and Region	All	All

<b>Required resources:</b>	<b>Land type:</b>
\$	All

#### Complementary Guidelines:

- 4.1 Access and Intersections, specifically [Guideline 4.1.6](#)
- 4.2 Corridors, specifically [Guideline 4.2.1](#)
- 4.4 Requirements, By-Laws, Policies, and Practice

#### 2.2.4 Consider freight movement needs and impacts when expanding existing *employment areas* or creating new *employment areas*

When expanding or creating new *employment areas*, preference should always be given to selecting locations within existing *settlement areas* that are near provincial highways, major inter-regional highway accesses or other key transportation facilities. Consideration should also be given to creating new *employment areas* adjacent to existing *employment areas*. This helps to minimize land use conflicts. Clustering of like uses also minimizes the conflicts that may be experienced along freight routes/corridors and the type of on-coming traffic that transport trucks may run into when exiting or entering a site.

Understanding the accessibility and freight movement needs of different types of employment uses, such as office uses or warehouse uses, will help to determine which sites are more appropriate for which type of employment use. For example, office uses will place higher priority on transit and *active transportation*, manufacturing or warehousing place higher priority on access to the regional provincial highway system, while mixed use buildings generate additional freight and service movements from the commercial tenants.

Figure 2.3: Locating new employment areas

When locating new employment areas, consideration must be given to their ease of access.



## Strategies

### Expanding Employment Areas

- a. Plan for new and expanded *employment areas* to be located close to *settlement areas* adjacent to, or in the vicinity of transportation facilities, such as *intermodal facilities*, rail yards, airports, ports and major highway interchanges, while continuing to direct development to *settlement areas*.
- b. Establish priorities and criteria for determining the appropriate location for new/expanding *employment areas* and to evaluate proposals for conversion of employment lands to non-employment uses based on proximity to freight assets.
- c. Promote brownfield redevelopment and *infill*, including the adaptive re-use of heritage buildings and structures. Where brownfield remediation is being considered, the requirements of the existing brownfields redevelopment regulatory framework under the Environmental Protection act must be consulted.
- d. Only consider expansion of *employment areas* for development of new employment uses if appropriate *infill* and brownfield sites cannot supply an adequate amount of new employment land, or if sites for specific uses cannot be found.

### New Employment Areas

- a. Identify potential locations for future *employment areas* within the municipality that are serviced with municipal water and sewer infrastructure (roads, water, sewer and electricity).
- b. Identify freight needs from various employment uses (e.g., industrial, manufacturing, office, *logistics*).
- c. Direct *freight-intensive land uses* to areas well served by major highway, airports, marine ports and rail.
- d. Direct heavy industry to areas adjacent to rail yards and corridors within *settlement areas* to minimize land use conflicts.
- e. Direct travel-intensive, higher density employment uses (e.g., office) to areas closer to *sensitive land uses* and well served by transit.
- f. Strategically select locations based on proximity of transportation or freight-movement assets to the site, and compatibility with surrounding uses (i.e., if a rail siding runs along major freight corridors, then this is a preferable location for industrial land uses). Preference should be given to *infill* locations in close proximity to long-distance highway infrastructure for freight-intensive uses, and also to promote the clustering of freight-intensive uses together.

**Scope:** District, Municipal, and Region

**Settlement size:** All

**Setting:** All

**Required resources:** \$



k.

### Complementary Guidelines:

- 2.4 Improved Integration of Transportation and Land Use Planning, specifically Guideline 2.4.1
- 3.2 Industrial Sites
- 3.3 Office Sites
- 3.4 Retail Sites
- 3.7 Site Design to Support Freight Mobility in Existing Urbanized Areas
- 3.9 Site Design to Coordinate Freight Transportation with Public Transit, Cyclists and Pedestrians
- 3.10 Rural Sites
- 4.3 Freight Gateways, specifically Guideline 4.3.2

Figure 2.4: Stratifying uses to improve land use compatibility



Stratification of uses helps to improve land use compatibility. It is important to create buffer areas between two incompatible uses such as residential and manufacturing areas in order to preserve the quality of life of residents.

Figure 2.5: Public transit stop in an employment area



Locating bus stops within *employment areas* improves transit ridership in highly congested *employment areas*, which ultimately reduces automobile dependence, and in turn results in more efficient freight movements. However, transit needs should be balanced with freight movement needs.

Figure 2.6: Opportunities to reuse existing buildings



This image portrays vacant employment space for lease. Before considering expanding *employment areas*, opportunities to reuse the existing available space should be thoroughly explored.

- h. Consider opportunities to protect and optimize the use of existing freight assets when evaluating proposals for *employment area* conversions.
- i. Consider employee traffic, freight movements and access to highways, how other uses (such as residential and institutional uses) will also grow in the future and how those uses will interact with the expanded *employment area*.

### Planning for Employment Areas

- a. Include a buffer on employment lands to decrease the noise and lighting disturbance on adjacent *sensitive lands*.
- b. Implement appropriate setbacks between *employment areas*, industrial sites and distribution centres, and natural heritage features.
- c. When planning employment uses in rural *settlement areas*, municipalities should consider the location of existing and planned infrastructure, along with the separation of sensitive uses to determine the best location for freight facilities and nodes.
- d. Consider the needs of freight movement and transit movement when planning for transit in *employment areas*.
- e. Improve opportunities for cyclists and *pedestrians* to help alleviate the traffic volumes within and around existing *employment areas*.
- f. When providing opportunities for cycling and *pedestrian* movements, avoid locating travel lanes along major goods movement corridors. Rather, consider providing alternative routes for cyclists, or providing landscaped buffers or barriers to separate users.

Figure 2.7: Expansion into rural areas should be a last option



Expansion of employment uses into rural areas should be considered as a last option when all other options cannot fulfill spatial requirements. This photo depicts industrial lots for lease/sale in a rural setting.

### 2.2.5 Plan for efficient freight movements and complementary land uses around multimodal freight systems

An efficient multimodal freight system is essential for the industries that receive products by all modes.

Air freight is very time sensitive, and therefore must be supported by reliable infrastructure to ensure just-in-time delivery. Warehouse space and operation yards provide excellent examples of compatible uses that also serve the cargo needs of the industries using the airport. These facilities play a critical role in providing timely and efficient delivery of goods and services to communities.

Ontario's marine ports contain facilities that have excellent connections to road and rail services. *Marine facilities* tend to have accompanying land use requirements to accommodate storage container delivery and distribution.

Many older port facilities in Ontario are located very close to historic town centres. In some cases, these historic port areas have become desirable places for new mixed use development and as a result many ports have already lost their function as a freight movement centre. Residential and mixed use developments will likely continue to place pressure on existing marine port facilities. Consideration must be given to the functionality of the port for freight when planning for land use changes. If changes in land uses surrounding ports begin to remove the key land uses and corridors (i.e., for exceptional loads) necessary to support the freight industry, the success of ports will be compromised. New development in port areas makes it increasingly difficult for the movement of freight leaving the ports and accessing highways or expressways. Municipalities should find a way to balance the needs of the freight industry and that of the other users of the port.

The efficient movement of freight in a multimodal system requires an efficient rail network. The rail mode is often used to move bulk shipments and other commodities to industrial facilities at *intermodal* terminals and port facilities.

For more information on land use in the vicinity of freight facilities, see the Provincial Policy Statement (<http://www.mah.gov.on.ca/Page215.aspx>) and the Noise Exposure Forecast (<http://www.tc.gc.ca/eng/civilaviation/standards/aerodromeairnav-standards-noise-nef-924.htm>).

For more information on the Toronto Port Authority, please visit [www.torontoport.com](http://www.torontoport.com).

Figure 2.8: Port with a buffer area containing complementary uses



Harbour-related freight uses are buffered from *sensitive land uses*, while the old historic harbour has been re-purposed for recreational uses. There will be increasing pressure over time to have more dense development within port areas.

## Strategies

### Scope: Settlement size: Setting:

All All All

### Required resources: Land type:



### Complementary Guidelines:

- 3.2 Industrial Sites
- 3.3 Office Sites
- 3.4 Retail Sites
- 3.7 Site Design to Support Freight Mobility in Existing Urbanized Areas
- 4.3 Freight Gateways, specifically Guidelines 4.3.2, 4.3.3, and 4.3.4
- 5.2 Implementation Tools

- a. Preserve and protect existing freight oriented land uses surrounding *intermodal facilities* at marine ports, airports, and rail yards.
- b. Designate and zone land to allow for the expansion of existing freight oriented land uses around marine ports, airports and rail yards to provide greater capacity for the future.
- c. Locate *intermodal* terminals and freight consolidation facilities adjacent to each other.
- d. Consider the industry operations, freight flows and volumes desirable to preserve or grow, and how best to gain economies of scale in terms of clustering.
- e. Encourage retail distribution centres and freight hubs to locate near *intermodal facilities*.

### 2.2.6 Protect smaller scale freight movement, such as mail delivery, courier services, and daily restaurant and retail deliveries to ensure an effective and efficient use of resources

Smaller delivery vehicles are often used when there are relatively low volumes of freight being moved or in more urban areas where there are constraints on the movements of larger vehicles. Municipalities can improve the efficiency of small-scale delivery operations by understanding their needs and providing space or infrastructure to help them operate efficiently.

Where convenient, and on-site loading docks cannot be provided, locations for on-street lay-bys with strict time restrictions limiting use to just a few minutes may be a suitable alternative. Alternatively, small side streets can serve as loading areas for adjacent developments.

Where possible, grouping uses that require relatively small freight movements will allow a more efficient use of space, with the potential for a shared loading facility. However, consideration must be given to the current and potential future demands of each user to provide an adequately-sized loading facility.

Use time-of-day restrictions on truck movements appropriately. Freight is transported on a 24/7 basis yet truck movements are often restricted on many routes for certain periods of time (e.g., 7 p.m. to 7 a.m.) or are prohibited altogether. This forces trucks to travel greater distances or at more inappropriate times (e.g., during peak hours where there is more congestion) which imposes greater costs on manufacturers and shippers which is ultimately passed on to



consumers in the form of higher prices. This further impedes the competitiveness of firms, areas and communities.

A progressive truck route network is one where the needs of commerce and residents are balanced. Safe, efficient and connective routes which minimize out-of-way travel should be provided which can also minimize impact on residential communities.

## Strategies

- a. **Standards for Small Freight:** When a municipality is reviewing its standards for roads, private developments and infrastructure within its urban core, consider the size and number of trucks and delivery vehicles that will need to negotiate the core area.
- b. **Share Loading Facilities:** Where there are a number of smaller retail or manufacturing uses that do not require constant access to a loading dock, consider shared loading facilities. Consideration must be given to the typical frequency and length of each user's deliveries.
- c. **Provide On-Street Lay-bys:** Develop on-street lay-bys reserved for short-term loading to allow delivery vehicles to make time-sensitive deliveries in constrained areas. Signage indicating a limited stopping period (typically ten minutes) and enforcement of that rule is generally required.
- d. Develop strategic locations for lay-bys such as locations that are close to the required users but not in a location where they will interfere with other community requirements.

### Scope:

Site, District,  
and Municipal

### Settlement size:



### Setting:



### Required resources:

\$ - \$\$

### Land type:



### Complementary Guidelines:

- 3.7 Site Design to Support Freight Mobility in Existing Urbanized Areas
- 3.8 Site Design to Support Freight Movement in New Mixed-Use Areas
- 4.1 Access and Intersections
- 4.2 Corridors

## 2.3 Planning for the Freight Movement Network

Figure 2.9: Traditional employment areas may not be located near highway access



Historically, *employment areas* were located near water and rail. More recent highway-related *employment areas* have developed to take advantage of sophisticated highway systems.

The following Guidelines provide strategic direction for planning for the freight network, and are intended to address transportation planning. The Guidelines also provide direction on considering strategic linkages between *employment areas* and the connections to the provincial or regional highway network. An effective freight movement network can help trucks maximize efficiency and increase *logistics* options that will benefit businesses, transportation providers and consumers, while avoiding or minimizing conflicts in residential areas.

Planning for freight within the context of an overall strategy for how streets are designed and used is important; likewise it is also important to recognize that the strategies needed to accommodate freight will vary depending on both traffic flows and land uses in the area. Context sensitive solutions are necessary to ensure that freight movement is part of the planning discussion while balancing priorities and solutions to manage the needs of *pedestrians*, cyclists, transit, automobiles and trucks. *Complete streets* are designed to balance the needs of all modes of transportation on a road, including freight. However, not all streets are the same. Trade-offs between street design features should reflect long-term objectives for the street and surrounding area. In rural or heavy industrial areas, *complete streets* may look very different from those in downtown or main street areas.

Figure 2.10: An example of a complete street

*Complete streets* are designed, built, operated and maintained for all modes of transportation and for all types of users.



### 2.3.1 Develop Strategic Truck Route Network

A strategic freight or truck route network should be continuous and harmonized with adjacent municipalities to the greatest extent possible. The network should promote multimodal connectivity and include routes/corridors within the network that expedite freight movement (e.g., signage, enhanced signalling, higher speed limits, longer left turn lanes). The network also should define different categories of truck routes (primary/major, secondary/alternate, and routes with operating restrictions).

#### Strategies

- a. Develop functional classification of roads (arterial, collector, local).
- b. Identify primary truck routes and secondary truck routes based on the functional classification and character of the street, as well as the location of freight generators and freight receivers.
- c. Develop a coordinated truck route network that:
  - i. Efficiently links current and planned *freight-intensive land uses* to key inter-regional transportation facilities (e.g., provincial highways, modal transfer points);
  - ii. Provides access to commercial and *employment areas* within the municipality;
  - iii. Is coordinated with truck routes in neighbouring municipalities; and
  - iv. Where needed, accounts for special freight needs such as accommodating long combination vehicles or exceptional load movements.
- d. Recognize that freight needs will vary depending on the type of uses in the area (e.g., manufacturing, residential, commercial, downtown/main streets) and context sensitive strategies should be utilized.
- e. Identify context-sensitive strategies for *complete streets* that include freight considerations.
- f. Identify areas where truck traffic should be discouraged or limited due to *sensitive land uses*.
- g. Avoid or mitigate conflicts between truck routes and transit / cycling routes.

Scope:	Settlement size:	Setting:
Municipal and Region	All	All
Required resources:	Land type:	
\$ - \$\$	All	

#### Complementary Guidelines:

- 4.4 Requirements, By-Laws, Policies, and Practice, specifically Guidelines 4.4.1 and 4.4.2
- 5.2 Implementation Tools, specifically Guideline 5.2.5

### 2.3.2 Develop strategies and standards to ensure that freight movements are not impeded along freight corridors

In order to ensure that freight can be moved efficiently throughout the municipality, roads and highways need to be built and maintained to certain standards. The design, construction, maintenance and operational standards that apply to freight routes/corridors may be different from those that apply to other roads. Appropriate standards should be applied to all freight routes/corridors within the municipality. The standards should be designed to provide a balance between the needs of all road users for each particular road. The standards needed for each road will vary depending on the volume of freight traffic, the type, and the primary role of the road for freight traffic (extra-regional connector, or local delivery). Finding a balance ensures that no road users will be excluded from accessing the road.

Significant freight routes/corridors should be identified and maintained as such, and monitored to ensure freight movements are expedited.

#### Strategies

Scope:	Settlement size:	Setting:
Region	All	All
Required resources:	Land type:	
\$	All	

#### Complementary Guidelines:

- 2.4 Improved Integration of Transportation and Land Use Planning, specifically Guideline 2.4.1
- 4.1 Access and Intersections
- 4.2 Corridors
- 4.3 Freight Gateways, specifically Guidelines 4.3.1 and 4.3.2
- 4.4 Requirements, By-Laws, Policies, and Practice

Curbside lay-bys can be off-line (i.e., cut into the sidewalk area) or in-line (i.e., occupy a traffic lane). Alternatively, service lanes can be provided. Two automobile parking spaces can be combined to provide one truck loading/unloading area.

- a. Develop minimum standards for freight corridors. Standards should include:
  - i. **Design elements**, such as minimum lane widths, minimum curve radii, minimum intersection standards, minimum intersection spacing, bridge design;
  - ii. **Construction elements**, such as surface materials, subsurface materials, signage, and traffic control standards;
  - iii. **Maintenance elements**, such as providing priority snow clearing, providing emergency road repairs, scheduling general maintenance to minimize delays and detours;
  - iv. **Operational elements**, such as timing of signals; and
  - v. **Communication elements**, such as appropriate signage.

In some cases special standards may need to be developed for special routes, such as those with very heavy usage, and routes frequently used for oversized loads.

- b. Ensure that municipal road and laneway design standards for all road types in a community can accommodate the appropriate size of truck.
- c. Ensure that the design standards will accommodate all road users safely.
- d. Ensure that existing Official Plans, Secondary Plans, and municipal zoning allows for future freight related land uses along key transportation corridors.

### 2.3.3 Identify where rest and fuel facilities are provided along freight routes/corridors

Rest areas and truck stops are an important element of the Ontario road network. These facilities contribute to the safety and efficiency of freight operations in Ontario and also provide necessary amenities for truck operators to keep trucks on the road. Rest areas and truck stops also contribute to the local economy by providing jobs and generating tax revenue from sales of petroleum products and other related products.

Municipalities can encourage the development of these facilities on municipal roadways, where they do not already exist, by identifying them within their official plan or other planning documents, and by providing a zoning category and zoning by-law provisions. Municipalities should also consider opportunities to support reinvestment in rest areas at abandoned gas stations through brownfield rehabilitation. Areas for this opportunity should be identified in community improvement plans and consideration should be given to providing financial incentives to attract investment in rehabilitating abandoned sites.



Figure 2.11: Flying J Truck Stop in Napanee, Ontario



Typical rest stops in Ontario provide truck facilities such as fuel, truck washes, truck repairs, and also include food establishments. These rest stops can contribute to the local economy by providing jobs and generating tax revenue, but future planning of this type of facility should encompass sustainability principles and policies regarding efficient use of land.

Figure 2.12: Typical road side rest area with washrooms and space for parking trucks

Road side rest stop can be in the form of a parkette, containing washroom facilities and ample space for parking trucks. Opportunities are provided for drivers to rest, use the washroom and make phone calls.

## Strategies

- Identify strategic locations along freight corridors for the provision of rest area services.
- Plan for and work to establish rest and fuel facilities for truck drivers where deficiencies are noted. Account for long combination vehicles in the design of these facilities if sites are within approximately two kilometers of a 400-series highway or equivalent.
- Introduce signage indicating rest area information.
- Develop informal municipal rest stops/parkettes with washroom facilities to support freight movement and tourism.
- Coordinate with neighbouring municipalities.

**Scope:**

Municipal and Region

**Settlement size:**

All

**Setting:**



**Required resources:**



**Land type:**



**Complementary Guideline:**

4.4 Requirements, By-Laws, Policies, and Practice, specifically Guideline 4.4.1

### 2.3.4 Consider freight needs and impacts resulting from new or expanded *freight-intensive land uses* and areas

When considering the location of signed freight routes/corridors the shortest and most efficient corridors will usually be the preferred choice, however consideration should be given to the interaction with other users of the road, including automobiles, transit vehicles, bicycles and *pedestrians* in order to understand the relationship between them. In all scenarios, the Municipal Engineers Association Class Environmental Assessment process must be consulted and followed to mitigate impacts to surrounding uses. A balanced approach that considers economic, environmental and social issues to the community, along with any possible physical restrictions, should be taken.

Generally trucks follow the existing arterial streets through a built-up community. Through the *freight audit*, municipalities should identify the primary freight corridors within their jurisdiction, the demand on those corridors, and key generators and attractors. Municipalities should also consider secondary or alternate freight corridors taking into consideration the types of land uses in the area to avoid conflicts. This information will provide municipalities with the data needed to determine if there are any areas where there is a need to re-route truck traffic to address other planning considerations.

The following figure shows four options that provide alternatives to addressing truck traffic which passes through a town's main street area. For each option, the advantages and disadvantages are presented. The municipality should review the options available to determine which works best in their specific context in order to best address safety, efficiency and practicality.

### 2.3.5 When truck routes and corridors are shared with transit routes, consider alternatives to allow the efficient flow of both

As urban communities become more heavily populated, the demand for transit use increases. This can often have a detrimental effect on freight by limiting the space available for truck movements. If possible, major signed freight routes and corridors should be located on roads parallel to the major transit routes, however where that is not possible, careful design must be used that enables road safety for all users. It is also recognized that the majority of roads (arterial and collector) are used for some form of freight movement (i.e., for garbage collection and mail distribution), however, new *freight-intensive land uses* should be directed to specified truck or haul routes.

The Ontario Trucking Association (OTA) has developed guidance on the development of truck routes for Ontario municipalities.

<http://www.omkn.ca/OMKN-Docs/Best-Practices/Beneficial-Reports/111201OTAGuideFINAL.aspx>

Measures to enhance the priority and performance of transit systems can be found in the Ontario Ministry of Transportation's *Transit-Supportive Guidelines*.

<http://www.mto.gov.on.ca/english/transit/supportive-guidelines.shtml>

Figure 2.13: Alternatives to addressing truck traffic that passes through a town's main street area

All through and local traffic must pass through constrained historic main street area leading to congestion and conflicts. Four alternatives are shown. Note: While option 4 is preferred for transportation outcomes, an Environmental Assessment would be required to assess options and take other factors into consideration.

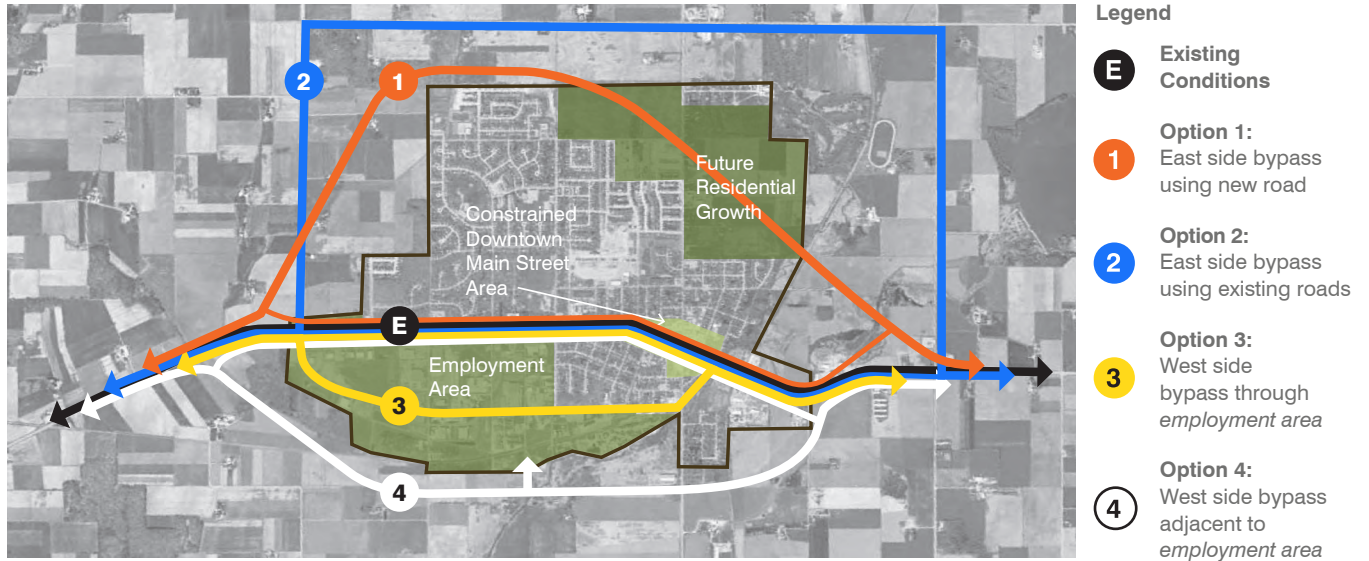

Option	Advantages	Disadvantages
<b>1</b> Option 1: East side bypass using new road	<ul style="list-style-type: none"> <li>• Time savings for through traffic</li> </ul>	<ul style="list-style-type: none"> <li>• Conflicts with development area</li> <li>• Requires land acquisition</li> <li>• Does not service the <i>employment area</i></li> </ul>
<b>2</b> Option 2: East side bypass using existing roads	<ul style="list-style-type: none"> <li>• Minimal cost</li> <li>• Encourages non-freight traffic to remain on the main street</li> </ul>	<ul style="list-style-type: none"> <li>• Little time savings for through traffic</li> <li>• Turning movements will add to travel time</li> <li>• Does not service the <i>employment area</i></li> </ul>
<b>3</b> Option 3: West side bypass through <i>employment area</i>	<ul style="list-style-type: none"> <li>• Makes best use of existing roads</li> <li>• Direct access into <i>employment area</i></li> </ul>	<ul style="list-style-type: none"> <li>• Limited time savings for through traffic</li> <li>• Potential conflicts with existing uses</li> </ul>
<b>4</b> Option 4: West side bypass adjacent to <i>employment area</i>	<ul style="list-style-type: none"> <li>• Time saving for through traffic</li> <li>• Good access to <i>employment area</i></li> <li>• Fewer turning movements</li> <li>• No conflicts with existing or proposed uses</li> </ul>	<ul style="list-style-type: none"> <li>• Requires land acquisition</li> <li>• May have environmental impacts</li> </ul>

By their very nature transit nodes are almost always also high *pedestrian* usage areas. Careful design of the connecting corridor street should always include the safe design of *pedestrian* crossing points. Visibility and traffic speed are key considerations to help ensure that the street is safe for *pedestrians*.

## Strategies

<b>Scope:</b>	<b>Settlement size:</b>	<b>Setting:</b>
All		
<b>Required resources:</b> \$ - \$\$\$	<b>Land type:</b> All	

### Complementary Guidelines:

- 2.4 Improved Integration of Transportation and Land Use Planning, specifically Guideline 2.4.1
- 3.9 Site Design to Coordinate Freight Transportation with Public Transit, Cyclists and Pedestrians
- 4.1 Access and Intersections
- 4.2 Corridors

### a. Centre Medians:

- i. Provide a safe location for *pedestrians* to stand when getting off a transit vehicle or while they are waiting to cross the street.
- ii. When designing roads with a centre median, consider how that median will affect the operation of freight, especially trucks.
- iii. Require new site development to be oriented so that large vehicles can easily access the site from side streets.
- iv. Promote shared driveways, access easements or new collector streets.
- v. Consider options for allowing large trucks to turn around safely once on the arterial street if an alternative access point cannot be found. The simplest solution is generally a loop of collector streets connected to the major arterial street at traffic signals. Right turn movements are preferred. Where suitable collector streets do not exist and cannot be created, other options need to be considered.

Figure 2.14: Truck supportive median options

When a median (including a centre-of-street transit line) prevents left turns into or out of a driveway, provisions for truck-friendly turn-around options must be provided.

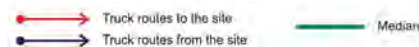

Municipalities should reference the Ontario Ministry of Transportation *Transit-Supportive Guidelines* 2.3.1 and 3.1.4.8 for additional information on determining the location of transit stops.

### b. Intersections:

Intersections are not only the most constrained locations on roadways, but they are also the most likely place for conflict between freight, transit vehicles, *pedestrians* and other road users.

- i. Consider locating transit stops and stations on the far side of the intersection (i.e., transit vehicles cross the intersection then stop). Far side stops can expedite travel times as well and therefore are attractive from a transit perspective.
- ii. Avoid or minimize the use of right-turn channelized turning lanes that create traffic islands at intersections with high



volumes of pedestrian activity. However, where these are appropriate, there should be enough curb radius with a clear distinction between the road surface and the sidewalk to remind people to keep back from the edge of the curb.

- iii. In areas of increased *pedestrian* activity and infrequent opportunities for safe crossing at signalized intersections, incorporate stop signs or activated crossing signs into the design of intersections.
- iv. Consider the use of pavement markings to alert drivers and indicate *pedestrian* priority.

Figure 2.15: Near and far side bus stops

The diagram depicts the difference between near and far side transit stops. In constrained locations, transit stops and stations can be moved to the far side of the intersection to avoid impeding automobiles, trucks, and cyclists who wish to turn on or off an arterial street.

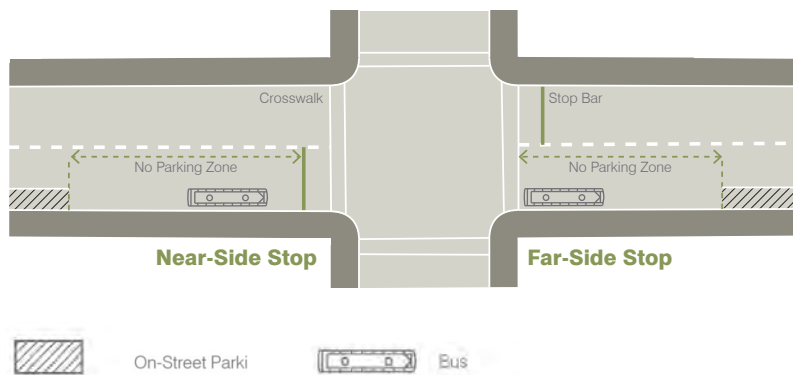

Municipalities should reference the Ontario Ministry of Transportation *Transit-Supportive Guidelines* 2.1.1 and 2.3.1.5 for additional considerations when designing intersections that support transit.

Figure 2.16: Right-turn channelized lanes can make intersections unpleasant for pedestrians

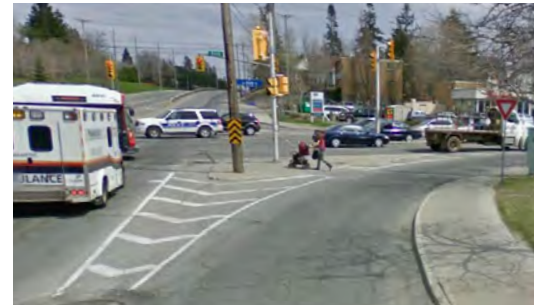

Channelized right turn lanes can make it difficult, unpleasant, and potentially dangerous for *pedestrians* to cross the street.

### c. *Pedestrian safety and visibility:*

- i. Consult with various users of the road to identify their needs and respective design requirements along the street, adjusting standards where necessary and balancing design trade-offs where they exist.
- ii. Utilize appropriate urban design to create an effective buffer between vehicles on the street and *pedestrians*, recognizing that street furniture and landscaping can be an impediment to freight pickups and deliveries; consideration must also be given to *pedestrian* visibility, particularly at intersections and driveways.
- iii. Locate trees and street furniture strategically to not block a driver's view or sightline of *pedestrians* when turning corners or entering or exiting driveways. This can be accomplished through minimum setbacks for buildings and maintaining visibility at sight triangles.

Figure 2.17: Street furniture along an arterial street



Street furniture can help make the street more attractive and protect *pedestrians* from vehicles, but maintaining visibility at intersections and driveways is important.

Freight vehicles will generally need to access most streets in a community. When planning for *complete streets*, it is important to appropriately plan and consider the needs of these vehicles.

Figure 2.18: Idealized overlapping grids of truck routes/corridors and major transit lines



A conceptual grid road network showing alternating truck and transit routes and corridors on parallel arterial roads.

- iv. Determine appropriate traffic speed with *pedestrian* safety and comfort in mind.
- v. Implement signage and wayfinding to inform *pedestrians* of where it is safe to walk, and where transit stations are located.
- vi. Avoid rolled curbs on transit routes as there is a potential safety issue if *pedestrians* are waiting on the median.

d. **Separate Truck and Transit Routes:**

- i. Consider minimizing conflicts between major freight corridors and major transit services by separating them onto two different roads. Most urban roads will not require segregation of trucks and transit, however, freight and transit routes should be separated where there are conflicts causing concerns for the safety of *pedestrians* and when transit is negatively impacting the efficiency of freight transport.
- ii. Consider alternating transit corridors with freight corridors on parallel arterial roads, where possible, and only if a reasonable walking distance to effective transit service can be maintained.
- iii. Consider the land use, place-making and community development goals of the community. Transit should be located on roads where high quality, pedestrian-oriented development and place-making opportunities exist.

When re-routing freight movement, consideration should be given to the road characteristics and adjacent land uses, and if the infrastructure is in place to support freight transport. Another key consideration is to understand what type of road users currently travel on the alternative route; the safety of all road users needs to be carefully considered.

### 2.3.6 Plan for efficient operations of the road network particularly as it interfaces with the rail network and associated facilities

Figure 2.19: Grade-separated rail crossing



A typical grade-separated rail crossing allows for the free flow of automobile and truck traffic, enhances safety and helps alleviate congestion.

Rail freight movement currently plays a key role in the transportation of goods in Ontario and is essential to the province's economy and future economic development. The province's rail system serves businesses and industries that create jobs, and transports much of the freight that Ontarians use each day. The current rail network in the province is being expanded in key corridors to meet future commuter (passenger) rail demands and to meet the needs of current users (including freight), as rail infrastructure is often shared.

Consideration should be given to protecting unused or under utilized rail sidings and branch lines for future use, either for

freight movements or for rail-based public transit. Failing that, their conversion into a bicycle or recreational trail could be considered.

Rail *intermodal* container facilities are particularly high volume facilities, driving high volumes of freight on roads and rail lines in the region. Municipalities should consider the freight and rail network in their jurisdiction and work with railway companies to ensure that at grade rail crossings are avoided or minimized, crossings are effectively planned and that there are enough grade separated crossings to allow for reasonable vehicle flow.

In addition to the strategies set out below, municipalities should consult the D-Series Guidelines as *intermodal facilities* are considered point sources of noise.

### Strategies

- a. Avoid or minimize the number of at-grade rail crossings. Examine the surrounding road network to ensure that adequate capacity and design is possible, including potential grade separations over the rail corridor. Eliminating at-grade road/ rail crossings is the most effective way to minimize *pedestrian/ vehicle - train* collisions.
- b. Identify and protect *intermodal facilities* by designating, zoning and providing additional land for supporting land uses.
- c. Establish a buffer for noise around existing *intermodal facilities*, and around future multimodal expansion locations.
- d. Ensure that access to *intermodal facilities* is direct and provides sufficient capacity for inbound and outbound movements and for queuing of trucks.
- e. Where possible, truck routes should have grade separated crossings of heavily used rail lines.
- f. Develop setbacks, buffers and noise mitigation requirements for new *sensitive land uses* located adjacent to rail corridors.

<b>Scope:</b>	<b>Settlement size:</b>	<b>Setting:</b>
All	All	All
<b>Required resources:</b>	<b>Land type:</b>	
\$	All	

**Complementary Guideline:**

4.3 Freight Gateways, specifically Guidelines 4.3.1, 4.3.2, and 4.3.3

The Railway Association of Canada (RAC) and the Federation of Canadian Municipalities (FCM) have developed proximity related reference information to assist municipalities in understanding planning issues related to railways in their communities. For more information on planning adjacent to rail corridors, see the FCM - RAC Guidelines for New Development in Proximity to Railway Operations. <http://www.proximityissues.ca/>

### 2.3.7 Consider safety and comfort of all road users, when new *active transportation* infrastructure or improvements to existing infrastructure is proposed adjacent to *truck routes/corridors*

Providing opportunities for *active transportation* (i.e., walking, bicycling etc.) is an important element that should be considered for most streets. However, in some cases, parallel routes will be encouraged rather than making global design accommodations. Balancing truck needs with these uses can be complicated, and safety should always remain a primary consideration.

When designing roads that must accommodate both high volumes of trucks and *active transportation* uses, consider separating the elements, either by placing one or the other on a parallel route, or by using a boulevard as a spatial buffer.

Figure 2.20: Example of bicycle lane



Signage, road markings, and simple design elements should be considered to help keep cyclists safer along busier freight routes and corridors and inform drivers of their presence.

Figure 2.21: Bicycle path options

The diagram depicts three separate bicycle path options and in what situation each should be utilized. Note that it is not practical in all cases to construct bicycle paths. Even in the best plans there can still be conflicts as cyclists may choose to use the “shortest” route.

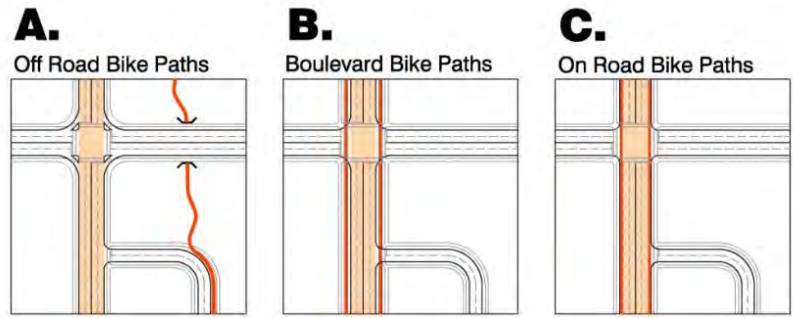

Truck Route (orange box)      Bike Route (red line)

		Volume of Bicycles		
		Low	Medium	High
Volume of Trucks	High	<b>B.</b>	<b>A.</b>	<b>A.</b>
	Medium	<b>C.</b>	<b>B.</b>	<b>A.</b>
	Low	<b>C.</b>	<b>C.</b>	<b>B.</b>

**Strategies**

<b>Scope:</b>	<b>Settlement size:</b>	<b>Setting:</b>
All	All	All
<b>Required resources:</b>	<b>Land type:</b>	
<b>\$ - \$\$</b>	All	

**Complementary Guidelines:**

- 2.4 Improved Integration of Transportation and Land Use Planning, specifically Guideline 2.4.1
- 3.9 Site Design to Coordinate Freight Transportation with Public Transit, Cyclists and Pedestrians, specifically Guideline 3.9.2
- 4.1 Access and Intersections
- 4.2 Corridors

- a. **Off Road or Parallel Routes:**
  - i. Consider finding alternative routes for bicycle or trucks when there is a high volume of bicycle traffic along an arterial road that is also used by a high volume of trucks.
  - ii. Locate bicycle trails, paths and routes in parks and open spaces and along collector streets where appropriate to avoid critical sections of major roads.
  - iii. Consider the need for underpasses or overpasses to increase the safety and accessibility of the bicycle route.
  - iv. Connect parallel bicycle routes to important destinations, including places of employment, as directly as possible.
- b. **Bicycle Lanes and Paths:**
  - i. Consider separating bicycle lanes or paths by a curb or landscaped boulevard where parallel routes cannot be found.
  - ii. Address issues such as climate, visibility at intersections and conflicts with *pedestrians* during the planning and implementation process.

- c. **On Road Bicycle Paths:**
- i. Design road elements, such as sewer grates and manhole covers, to eliminate the need for bicycles to swerve out into traffic to avoid them.
  - ii. Implement warning mechanisms such as signage and road markings to inform truck drivers of the presence of cyclists along the route.
- d. **Rural Roads:** Consider designating scenic bicycle routes in rural areas that avoid primary freight routes and corridors. Where freight routes and bicycle routes must coexist, continuous paved shoulders with appropriate signage are preferred.

### 2.3.8 Consider developing service roads for industrial parks adjacent to major provincial highways

Service roads running parallel to full access provincial highways can provide a viable alternative means to access sites that face the highway. Service roads eliminate the need for driveways to access the highway directly by providing vehicular access at safe intersection locations, while still providing site visibility from the highway. To be effective they need to be designed with curve radii, lane widths and sightline distances that are safe and appropriate for truck traffic.

#### Strategies

- a. Provide safe curve radii, lane widths and sightline distance features.
- b. Evaluate the visual characteristics of the service road and the landscaping between the highway. Landscaping should be attractive and appropriate for the location but should not block the view of signage and other corporate identification as this is what makes the highway facing locations valuable.
- c. Consider the effect on local traffic patterns as a result of the service road as it may help alleviate traffic problems on other streets.

#### Scope:

District

#### Required resources:

\$ - \$\$\$

#### Settlement size:



#### Land type:



#### Setting:



## 2.4 Improved Integration of Transportation and Land Use Planning

Municipalities need to also consider the requirements of the Municipal Engineering Association Class Environmental Assessment process.

The following Guidelines provide direction and strategies for integrated transportation and land use planning to create *complete communities*, as well as direction on the need to protect resources, and avoid or minimize impacts on sensitive uses, such as prime agricultural land and natural heritage features. Growth management is a key underlying objective.

### 2.4.1 When through freight routes are adjacent to existing or new *sensitive land uses* (i.e., residential, commercial, institutional or *significant* natural heritage features or areas), consider alternatives for minimizing or avoiding impacts

Figure 2.22: Freight route/corridor adjacent to an environmentally sensitive area

A landscaped buffer between the roadway and the natural feature can assist in mitigating the impacts associated with truck traffic.



As communities grow, it is expected that they will make more effective use of their land by creating denser and more efficient communities. This increases the likelihood that conflicts between uses will require mitigation through design. Freight-oriented facilities are particularly susceptible to conflicts due to their noise, air pollution, traffic and visual impacts. Transportation noise, from sources including road, rail, air and watercraft, all contribute to the noise environment. Noise on roadways that carry trucks and heavy vehicles is often associated with the acceleration, deceleration and braking of these vehicles. In addition, trucks carrying heavy loads often will cause vibration, as well as emit exhaust which impacts the immediate air quality of adjacent land uses. New residential, commercial or institutional development located adjacent to existing or future freight routes and corridors need to include noise studies to help determine if design features such as sound barrier walls or *berms* are to be constructed to help alleviate impacts from adjacent truck traffic. Information gathered in the *freight audit* can be used to help determine the appropriate mitigation strategies for the route. Municipalities should also ensure that they properly signal and sign roadways that are freight routes to mitigate future conflicts.

## Strategies

- a. **Road design:** Ensure that roads are designed, built, operated and maintained for all types of transportation modes and for all types of users.
- b. **Traffic Signals:** Traffic signals sometimes cause truck traffic to have to decelerate, which in turn may causes noise and air impacts to adjacent land uses. Provide fewer traffic signals along designated freight routes/corridors to reduce the need for trucks to accelerate and decelerate, in effect helping to avoid the creation of noise and air quality impacts on *sensitive land uses*, as well as increase efficiencies for freight operators.
- c. **Buffers:** Consider implementing buffers between the roadway and *sensitive land uses* / natural heritage features or areas to help minimize the impacts of freight routes and corridors on these sites, but also balancing this with the need to create compact communities.  
  
 Considerations and strategies that address shared roadways are further discussed in [Guidelines 2.3.2, 2.3.5, and 2.3.7](#).  
  
 When designing buffers, municipalities should also review the D-Series Guidelines to determine the appropriate size and type of buffer. The D-Series Guidelines do not apply to roadways, except for ancillary transportation facilities for an industrial land use, including shipping and receiving. Similarly, they do not apply to airports or railways, however they do apply to railway yards and other ancillary *rail facilities*. Accordingly, various types of freight-related infrastructure and activities may be subject to the Guidelines.
- d. **Rear Lotting:** Rear lotting is only appropriate in certain situations and it is not recommended in areas with moderate to high *pedestrian* activity.
- e. **Setbacks:** If the street is not intended to be a major urban *pedestrian* corridor, consider other options for mitigating the impact from noise, vibration and air-quality issues. One option is the provision of an appropriate setback from the roadway and the land use. Typically, naturally vegetated buffers can be incorporated as part of this setback.
- f. **Sound Barrier Walls:**
  - i. Installation of sound barrier walls along freight routes and corridors help to mitigate the noise and visual impacts of freight routes and corridors to *sensitive land uses*. Sound barrier walls are typically installed in areas where roadway noise impacts are greater than acceptable limits.
  - ii. Consider sound barrier walls at the time of development as part of the site plan control process, or part of the

<b>Scope:</b>	<b>Settlement size:</b>	<b>Setting:</b>
District, Municipal, and Region	All	All
<b>Required resources:</b>	<b>Land type:</b>	
<b>\$ - \$\$\$</b>	All	

### Complementary Guidelines:

- 2.2 Protecting Employment Areas and Freight Facilities, specifically Guideline 2.2.4
- 2.3 Planning for the Freight Movement Network, specifically Guidelines 2.3.2, 2.3.5, and 2.3.7
- 2.4 Improved Integration of Transportation and Land Use Planning, specifically Guideline 2.4.1
- 3.2 Industrial Sites
- 3.3 Office Sites
- 3.4 Retail Sites
- 3.5 Residential Sites
- 3.6 Institutional Sites
- 3.7 Site Design to Support Freight Mobility in Existing Urbanized Areas
- 3.8 Site Design to Support Freight Movement in New Mixed-Use Areas
- 3.10 Rural Sites
- 4.1 Access and Intersections
- 4.2 Corridors
- 4.3 Freight Gateways
- 4.4 Requirements, By-Laws, Policies, and Practice

Figure 2.23: Rear lotting

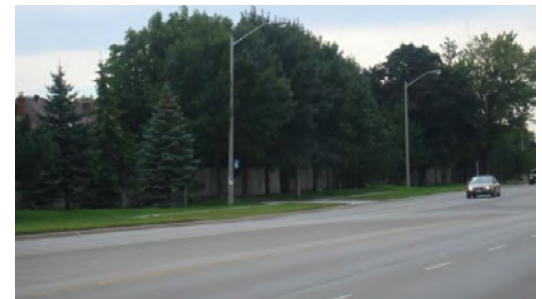

Rear of buildings facing the freight route/corridor can often result in a potentially unsafe and unattractive environment for the *pedestrian*. Design elements such as street trees, landscaping, lighting, and sound barrier wall design are important if this option is being considered.

Figure 2.24: Landscaped buffer with coniferous trees to assist in lowering the noise from the roadway from the employment area



A landscaped buffer can be achieved by using various types of trees between *sensitive land uses* and a warehouse structure. This type of buffer provides visual screening and acts as a noise barrier between the two land uses.

Figure 2.25: Living wall



A living sound barrier wall incorporate plants and flowers to make the walls more appealing in various urban contexts. This image shows a living sound barrier wall shortly after construction (first year of growth).

Figure 2.26: Street-related development



Developments adjacent to freight routes/corridors should employ noise/vibration/air-quality mitigation features built into the building to address noise from all vehicles.

environmental assessment process, to help mitigate impacts. There are also specific noise guidelines and processes that should be utilized.

The Ontario Ministry of Environment and Climate Change's Environmental Noise Guideline - Stationary and Transportation Sources has more information on the process for determining the need for sound barrier walls.

g. *Building Surface Density:*

- i. Consider the need for increased *building surface density* by constructing the outer walls of a building out of material (e.g., brick veneer) that will help lower or prevent the noise impacts of adjacent traffic on that building.
  - ii. Consider implementing drywall installation using resilient channels, which structurally decouple the interior drywall from the external wall to decrease the propagation of external noise into the dwelling. This is often used in new homes under active flight paths to major airports or in close proximity to rail lines.
  - iii. For existing buildings, consider options for retrofitting buildings to include noise mitigation measures if possible, however careful consideration should be taken to conserve any cultural heritage resources. For additional guidance and strategies on mitigating noise effects, municipalities should reference the appropriate Ontario Ministry of Environment and Climate Change publication providing guidelines on noise in land use planning.
- h. If the road is intended to be a major *pedestrian* corridor, require that buildings face the street and that they be constructed with noise-mitigating materials, such as those with high surface densities.
- i. *Architecture and Site Design:*
- i. Orient buildings so they do not overlook employment uses.
  - ii. Limit building heights so they do not overlook employment uses.
  - iii. Locate parking and outdoor amenity areas to create a spatial buffer.
  - iv. Consider the effect of lighting, and design to minimize impacts on adjacent uses, particularly for commercial uses open 24 hours per day.



j. **Road Planning Issues:**

- i. Through the planning approval process, ensure that access roads have the capacity and appropriate connections to accommodate the development traffic.
- ii. Consider the need for synchronized traffic signals to accommodate freight vehicles.

k. **Road Restrictions:**

- i. Consider lowering speed limits on freight routes and corridors to maintain a safe speed, while reducing noise and increasing the safety of all road users.
- ii. Implement road restrictions on the use of Jake brakes (i.e., engine retarder brakes) in residential areas and near *sensitive land uses*.

- l. **Freight Energy Efficiency:** Plan efficient and direct freight routes to support freight energy efficiency. Freight companies will spend less on fuel to maintain their fleet, which could indirectly lead to less greenhouse gas emissions.

m. **Ditches and Swales:**

- i. Consider the use of swales, ditches or infiltration galleries along to edge of the road or within a buffer area to catch run-off.
- ii. Consider the use of permeable pavements or curbing to collect surface run off and direct it to appropriate locations.

Figure 2.28: Bioswale



Roadside bioswales can be used to separate the roadway from a residential area. Bioswales are landscaped elements designed to remove contaminants from surface runoff water.

Figure 2.30: Roadside berm



Roadside *berms* adjacent to sensitive areas can be used as an efficient mechanism to direct spills away from natural features and areas, and will act as barriers to keep vehicles on their right-of-way.

Figure 2.27: Bilingual 'no engine brakes' traffic sign



The traffic sign provides a bilingual translation of 'no engine brakes' or Jake brakes within a residential community.

Figure 2.29: Roadside ditch



Roadside ditches can be used to separate the road from sensitive agricultural land.

Figure 2.31: A natural feature directly adjacent to the street with no ditch or bioswale present



Wetlands are particularly sensitive to run-off and should be separated.

The ESA 2007 protects species classified as Endangered or Threatened on the Species at Risk List in Ontario from being killed, harmed or harassed. In addition, the ESA 2007 protects the habitats of these species from being damaged or destroyed.

n. *Animal Crossings and Ecopassages:*

- i. Consider the need for animal crossings and *ecopassages* in heavily trafficked areas. The local Ministry of Natural Resources and Forestry office should be contacted regarding the locations of Species at Risk and their habitat, for advice on avoiding adverse effects, or for assistance in applying for an authorization under the Endangered Species Act (ESA) 2007.
- ii. Implement signage to make drivers aware of the risk of animal crossings.
- iii. Install provisions for wildlife crossings through underpasses/overpasses or culverts for those areas where crossings are frequent.
- iv. Through the Class EA process, consider alternative routes/road locations to reduce the amount of wildlife and watercourse crossings needed prior to construction.

Figure 2.32: Amphibian crossing



An amphibian tunnel underneath a newly constructed road.

Figure 2.33: Overhead animal crossing



The image portrays the conceptual design of a wildlife overpass. In extreme situations, a roadway overpass may be considered to help direct animals and get them across the road safely.

Figure 2.34: Animal crossing signs

Signs should be used to delineate deer and moose crossings to make drivers aware of the risk of animal crossings. These signs help to alleviate the danger of collision.



## 2.4.2 Addressing freight movement in rural areas

Freight movement in rural areas often involves the movement of heavy trucks, which can be carrying agricultural freight, aggregate/mining products, or forestry products, along with a range of supplies. Planning for freight routes and corridors should consider the needs of other traffic including *pedestrians* or cyclists, and even slow moving agricultural vehicles and small recreational vehicles (ATVs, mountain bikes), that are sharing the same roadway.

### Strategies

- a. **Agricultural Movement:** In many rural municipalities nearly every rural road is a freight route for some form of agricultural product.
  - i. Consider the frequency and demands of agricultural goods movement when designing or improving rural roads. Maintaining safe roads for all users plays an important role in supporting the local agricultural economy.
  - ii. Provide enough space to accommodate freight movement along rural routes while also allowing space for tractors and farm vehicles to share the road.
  - iii. Road signs should also be placed along shared roadways to inform freight operators of farm vehicles.
  - iv. Consider wider shoulders to allow farm vehicles to move off the roadway to allow space for freight vehicles and other vehicles to safely pass.
  - v. Consider the full range of needs and routings. Some uses have specific freight movement needs along rural roads, such as greenhouse uses (flower transport to flower auction), dairy facilities, livestock transport and grain drying. Consideration should be given to providing rural route linkages to promote the efficient transport of these agricultural uses.
- b. **Aggregate/Mining Resources Movement:** Quarries, gravel pits and mines can play a major role in a municipality's landscape and economy and are often associated with large amounts of freight.
  - i. Carefully locate access to these sites to minimize the impact on adjacent roads. Where possible, consideration should be given to providing longer on-site driveways to direct trucks onto the primary freight route rather than using collector roads as a connector. Where this is not possible, consideration should be given to having driveways connect with the higher order of available highways or roadways to minimize impact on municipal roads and *sensitive land uses*.

Figure 2.35: Sharing the road



Signs can be used to warn drivers of other road users, such as the potential of slow moving agricultural vehicles being present on the roadway.

#### Scope:

District,  
Municipal,  
and Region

#### Settlement size:



#### Setting:



#### Required resources:



#### Land type:



#### Complementary Guidelines:

3.10 Rural Sites

4.1 Access and Intersections

4.2 Corridors

Figure 2.36: Aggregate/mining facility truck entrance



Long on-site driveways allow trucks to be directed to a major arterial truck route/corridor rather than using collector roads as a connector. This mitigates conflicts with other road users and supports the movement of aggregate freight.

Figure 2.37: Main Street deliveries



Delivery trucks in a core urban area at mid-day can be a challenge. Off-peak delivery is an effective strategy for improving the efficiency of freight delivery to core areas of towns and cities.

### 2.4.3 In high density urban areas, deliveries and freight movements are particularly challenging. Consider implementing strategies to minimize conflicts between freight and other users

As communities in Ontario grow, their core areas are expected to experience growing intensification, even in smaller cities. Sustainable design, with walkable mixed-use areas with street-related retail shops will become more common and existing historic walkable mixed-use areas are likely to expand. While this development is generally positive for the community it tends to create conflicts with the delivery of freight to these areas.

Freight movements in core urban areas generally involve a series of linked trips with deliveries happening in the morning and pickups in the afternoon during off-peak hours. This can be a challenge because on-street parking for store customers will reduce both the vehicular capacity of a road to transport traffic, as well as the number of curbside parking opportunities for trucks. This necessitates the need to consider the following strategies.

#### Strategies

<b>Scope:</b>	<b>Settlement size:</b>	<b>Setting:</b>
District, Municipal, and Region		
<b>Required resources:</b>	<b>Land type:</b>	
		

#### Complementary Guidelines:

- 3.7 Site Design to Support Freight Mobility in Existing Urbanized Areas
- 4.1 Access and Intersections
- 4.2 Corridors, specifically Guideline 4.2.1
- 4.3 Freight Gateways
- 4.4 Requirements, By-Laws, Policies, and Practice, specifically Guideline 4.4.1

- a. Implement lay-bys to accommodate delivery vehicles only where appropriate, with due consideration for the potential for conflict with *pedestrians* and cyclists.
- b. Require the development of off-street loading spaces for new developments.
- c. **Rear Laneways:**
  - i. Implement effective design standards for rear laneways to allow access for small and mid-sized trucks, including garbage collection.
  - ii. Design laneways to be safe and to make them more visible from the adjacent buildings.
  - iii. Design laneways so that they align with adjacent development to provide for a seamless corridor that spans across all development blocks.
- d. **Strategic Access Points:**
  - i. Wherever possible, avoid direct vehicular access onto arterial streets from driveways or laneways.
  - ii. Minimize the number of accesses onto an arterial road. Where driveways do need to access an arterial road directly, care must be taken to ensure that adequate visibility for vehicles, *pedestrians* and cyclists is maintained.

- iii. Look for opportunities to provide off-street parking between buildings where space permits.
- e. **Intersections:** Adjust the timing of traffic signals at intersections during peak times to support both through movements and turning movements.
- f. **Lane Widths:** Provide a wider curb lane where streetfront deliveries need to be made (i.e., retail streets with many small shops) during off peak hours. If over 8.5 metres of pavement is available, providing a 3.5 metre left lane and a 5.0 metre wide curb lane will allow a truck to temporarily stop to make deliveries while leaving space for most small cars, motorcycles and bicycles to pass without affecting oncoming traffic.
- g. **Loading Zones:**
  - i. Designate on-street parking lanes or bays as loading zones to allow delivery vehicles, including mail trucks, to stop at convenient locations for short periods of time.
  - ii. Strategically locate parking lanes or lay-bys near the most frequented locations (e.g., mail boxes, banks) while not reducing the supply of on-street parking. In some cases loading periods can be limited to certain off-peak times.

Figure 2.38: Rear delivery lane



Laneways can serve mixed-use buildings (retail and residential) and provides enough space for deliveries and short term customer/visitor parking.



## 3.0 SITE DESIGN GUIDELINES

Building upon the land use guidelines presented in Chapter 2, the site design guidelines define a range of strategies that are common to most types of sites, and provide more detailed strategies for specific land uses.

The site design guidelines address the following land uses:

- Industrial;
- Office;
- Retail and restaurants;
- Institutional;
- Existing and new urban areas; and
- Rural sites (including quarries, mining and agricultural sites).

They also address coordination with public transit, cyclists and pedestrians.



## Legend

### Scope

Site

District

Municipal

Region

All

Applicable to all

### Settlement size



Small



Medium



Large

All

Applicable to all

### Setting



Rural



Urban

All

Applicable to all

### Required resources



Small



Medium



Large

All

Applicable to all

### Land type



Greenfield



Brownfield



Commercial



Residential

All

Applicable to all



Industrial



Mixed Use



Institutional



Denotes a strategy that supports fuel/energy efficiency or environmental protection.



## 3.1 Site Design Elements Common to All Sites

Some elements of site design are common to all sites, particularly those that promote the safe and efficient movement of trucks. This section addresses the common site design elements of:

- *Crime prevention through environmental design (CPTED)*;
- Site access;
- Fire truck access;
- Loading docks; and
- Garbage facilities.

### 3.1.1 *Crime Prevention through Environmental Design (CPTED)*

*Crime prevention through environmental design (CPTED)* should be considered for all types of sites in order to deter theft and increase the safety of freight facilities. The underlying principle of *CPTED* is that the way in which the site is designed directly influences the safety of people and of the property itself. *CPTED* design principles create more “eyes on the street” that allow people to see into and out of buildings and sites. *CPTED* principles provide natural deterrents to crime and help to deter threats to people, damage to private property and theft.

#### CPTED Strategy

- Incorporate *CPTED* principles into the design of sites.

### 3.1.2 Site Access Arrangements

Proper access arrangements from the external road network must be provided for trucks, regardless of the type or use of the site. The access system must provide a direct connection from the public road network, and must be designed to accommodate the projected types of trucks. The arrangements need to consider turning radii, driveway and turning lane length, and the spacing of access points in relation to adjacent intersections.

Figure 3.1: Examples of different types of sites

Each type of site has a different set of challenges and each will have a unique way of accommodating the necessary freight movements.

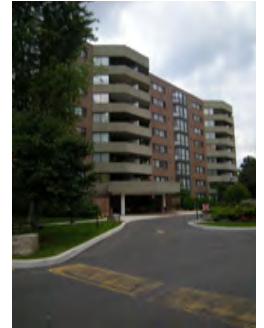

#### Resources for CPTED:

CPTED Ontario:  
<http://www.cptedontario.ca/index.php>  
 International CPTED Association:  
<http://www.cpted.net>

<b>Scope:</b>	<b>Settlement size:</b>	<b>Setting:</b>
Site	All	All
<b>Required resources:</b>	<b>Land type:</b>	
\$ - \$\$	All	

The Ontario Ministry of Transportation's *Commercial Site Access Policy and Standard Designs* (January 1994) should be consulted when designing site access.

### Site Access Arrangement Strategies

<b>Scope:</b>	<b>Settlement size:</b>	<b>Setting:</b>
Site	All	All
<b>Required resources:</b>	<b>Land type:</b>	
<b>\$ - \$\$</b>	All	

- Design accesses to accommodate the turning radii requirements of expected trucks and provide proper lane widths for on-site driveways.
- Provide adequate driveway length at access driveways and consider the provision of turning lanes for trucks leaving the site.
- Locate accesses appropriately in relation to intersections and consider providing exclusive turning lanes on the public road, especially if the external access is along a two-lane road. Driveway access point spacing from intersections should be based on the type of control at the intersection and the classification of the road.
- Provide signs on external roads alerting drivers of possible truck traffic, truck access points and slower moving farm equipment (see Figure 3.2).

Figure 3.2: Truck entrance sign

A truck entrance sign gives drivers warning of the potential for trucks to be entering the road.



Figure 3.3: Site arrangement for freight movement

In this example, the loading area is located at the back of the building and is screened from the surrounding uses. Parking for couriers/delivery vehicles is located in the front of the building, with its own designated building access point.

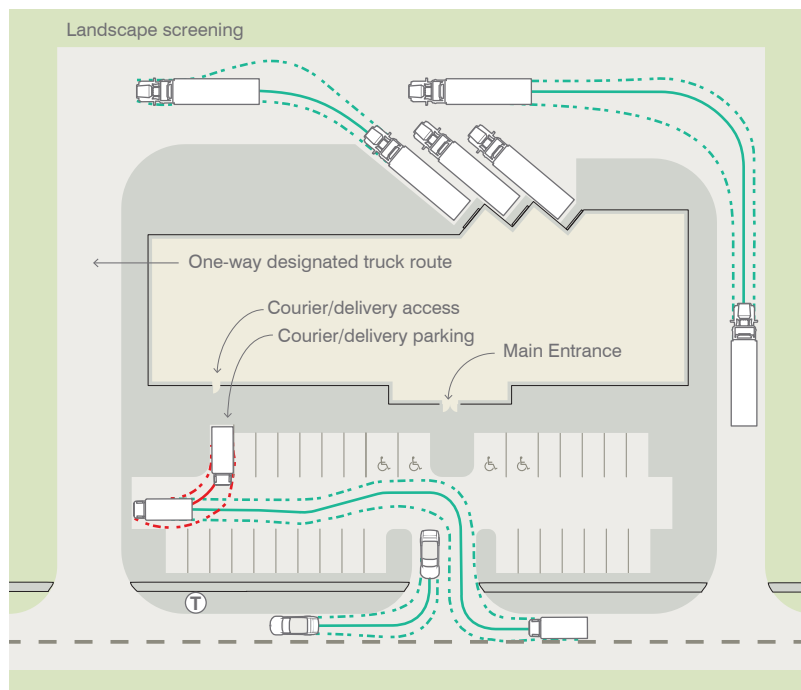
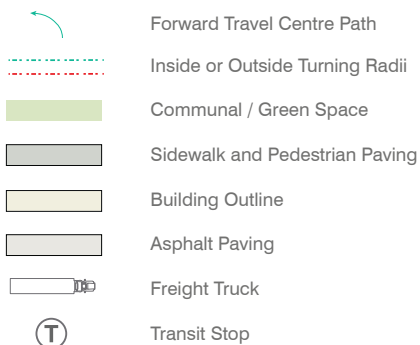

### 3.1.3 Provisions for Fire Truck Access

For all types of sites, it is critical to incorporate well-designed accommodation for fire truck access. Every site will need to submit a fire route plan to the municipality, to be reviewed by fire department officials. The plan needs to meet the fire route by-law requirements set out by the municipality. Typically, if a site access is designed to accommodate trucks as per the [Guideline 3.1.2](#), the designated space will accommodate a fire truck.

Site Designs must comply with the Ontario Building Code when designing a fire route. Truck staging or overflow areas should be provided away from the fire route to avoid blocking access for emergency vehicles.

#### The Ontario Building Code Guideline to Design an Access Route states:

##### 3.2.5.6 Access Route Design

- (1) A portion of a roadway or yard provided as a required access route for fire department use shall:
- Have a clear width not less than 6m, unless it can be shown that lesser widths are satisfactory;
  - Have a centreline radius not less than 12m;
  - Have an overhead clearance not less than 5m;
  - Have a change of gradient not more than 1 in 12.5 over a minimum distance of 15m;
  - Be designed to support the expected loads imposed by firefighting equipment and be surfaced with concrete, asphalt or other material designed to permit accessibility under all climatic conditions;
  - Have turnaround facilities for any dead-end portion of the access route more than 90m long; and
  - Be connected with a public thoroughfare.

### Fire Truck Access Strategy

- Follow the Ontario Building Code standard to provide for fire truck access.

Scope:	Settlement size:	Setting:
Site	All	All

### 3.1.4 Loading Docks

Loading docks are the arrival and departure points for shipment of goods by delivery trucks. The first step in designing a loading dock facility is to determine what loading demands the site will have. Considerations include:

- The types of trucks required to serve the needs of the site;
- How often truck shipments occur;
- How long the trucks will stay in loading/unloading areas;
- Site-specific requirements; and
- Building security issues.

Most municipal zoning by-laws provide standards for the size, type and number of loading spaces required, but specific uses or locations may require consideration of alternate standards. Designers should consider all possible uses of the building in the loading dock design.

Required resources:	Land type:
\$ - \$\$	All

In situations where access to the loading dock is impeded, angled access, or “saw-toothed” loading docks are a design solution that allows delivery vehicles to back into the dock yard at an angle without requiring the space to make a complete 90-degree turn for a typical straight back-in loading dock.

The *Whole Building Design Guideline* provides more information regarding loading dock and loading dock yard design. Information can be accessed at [http://www.wbdg.org/design/loading\\_dock.php](http://www.wbdg.org/design/loading_dock.php)

In addition to the requirements for loading docks found in most municipal zoning by-laws, there may be specific requirements or operational needs related to specific users. For example, certain retail, commercial, industrial and restaurant operators may have specific standards they use on a company-wide basis to accommodate a certain sized truck in order to keep their operations consistent. Another example is couriers, who may require or prefer on-site, short-term parking areas near the main entrance to the building.

### Loading Dock Strategies

<b>Scope:</b>	<b>Settlement size:</b>	<b>Setting:</b>
Site	All	All
<b>Required resources:</b>	<b>Land type:</b>	
<b>\$ - \$\$\$</b>		

- a. Provide a ramp from the truck parking area up to the loading dock to facilitate deliveries from smaller trucks, vans and other vehicles.
- b. Install edge guards and bumpers on the loading docks to prevent damage to the loading dock and to vehicles.
- c. Install overhead coiling doors as well as a personnel door for ease of access to and from the building for both goods and people.
- d. Cover open loading docks with a roof that extends beyond the dock to protect users and goods from poor weather conditions.
- e. For large loading dock facilities, install the dock manager’s room/booth in a location where the entire loading dock can be seen.
- f. Provide a room large enough to store all of the garbage bins and other waste bins.
- g. Provide easy access to a service elevator and temporary staging room for multi-storey buildings from the loading dock.

Figure 3.4: Loading dock ramp



A ramp is provided for deliveries not using the loading dock.

## Loading Dock Yard Strategies









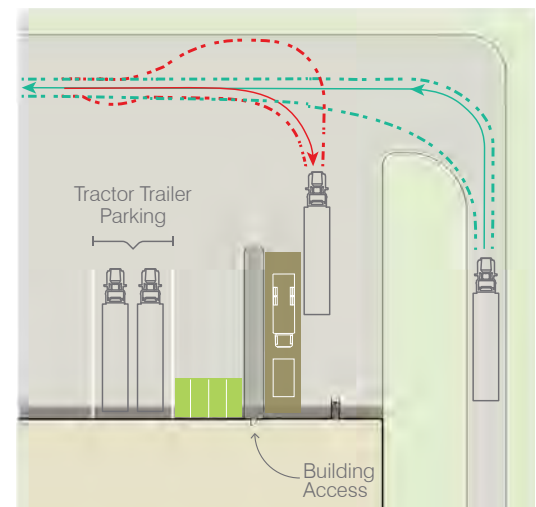

- Separate loading docks from public entrances by locating loading docks at the back or side of the building.
- Consider the operations of the site when determining the number of loading docks; for example, consider how often loading or unloading occurs and the duration of stay of trucks.
- Provide enough turning area to allow sufficient manoeuvring for a truck to complete a three point turn successfully.
- Provide parking spaces for smaller trucks such as courier and delivery vehicles.
- Consider the needs of couriers and the frequency of their deliveries. If appropriate, locate short-term courier parking near the main entrance of the building.
- Provide an entrance to the building for deliveries from smaller trucks that does not require crossing the loading bays for tractor trailers.
- Provide parking stalls for tractor trailer storage or trailer storage if needed. Trailer parking should be located in close proximity to the loading docks to keep all truck manoeuvres in one designated area.
- Construct the access to the loading dock yard to a size that is large enough to accommodate the expected number of trucks to avoid trucks waiting on-site or on external roads.
- Install lighting to illuminate the loading dock area and to illuminate the interior of the trucks making deliveries to increase visibility and reduce potential conflicts.
- Install buffers around the loading dock yard in the form of walls, screens or landscaping elements to shield the loading dock area from public view, to reduce noise and light pollution and to enhance security.
- Design the loading dock yard to ensure the safety and security of users with adequate lighting, locks on any doors and, if necessary, security cameras and emergency alarm mechanisms.

<b>Scope:</b>	<b>Settlement size:</b>	<b>Setting:</b>
Site	All	All
<b>Required resources:</b>	<b>Land type:</b>	
\$ - \$\$\$		

Figure 3.5: Example of loading dock design

In this diagram, the forward and reverse movements of the truck entering the loading area and backing into the dock are shown. Parking for tractor trailers and delivery vans has been provided. The delivery vehicle parking allows access to the building without crossing the loading bays. Also shown in this diagram is the designated area for garbage pickup.



	Forward Travel Centre Path
	Backward Travel Centre Path
	Inside or Outside Turning Radii
	Property Line
	Designated Garbage Area
	Communal / Green Space
	Sidewalk and Pedestrian Paving
	Building Outline
	Asphalt Paving
	Freight Truck
	Delivery Parking

### 3.1.5 Garbage Facilities

Standalone garbage facilities can be fenced and shielded in ways to conceal them from public view and reduce the visual impact of the facilities, while still providing adequate access for garbage trucks. Stand-alone garbage facilities can be included within a building or fenced/screened from public view if outside a building. Both approaches would completely hide the facilities from public view. Signage beside the garbage facilities should indicate that no parking is allowed and that the area is a loading zone for garbage trucks.

Landscaping can be used to shield the location of garbage facilities at a variety of land uses. The landscaping can blend in with the surrounding environment. The garbage facilities are still accessible but are less visible because of the landscaped buffer.

In some cases garbage is required to be mechanically compacted within regulation steel garbage containers which are placed on a designated loading pad. The loading pad should be designed to fully accommodate the width and length of the truck. Additional space outside of the loading pad should be provided to store the bins if a large amount of bins are required.

#### Garbage Facilities Strategies

<b>Scope:</b>	<b>Settlement size:</b>	<b>Setting:</b>
Site	All	All
<b>Required resources:</b>	<b>Land type:</b>	
\$ - \$\$	All	

- Design garbage and recycling facilities with enough vertical space to accommodate a front end loader garbage truck.
- Design garbage and recycling facilities with enough horizontal space to accommodate the movement of modern vehicles, including front-end loading vehicles.
- Locate garbage collection areas at the back of the building or away from the street where the building has its main entrance.
- Centrally locate any shared garbage facilities in order to limit the number of facilities that need to be provided in order to increase the efficiency of the garbage collection.
- Provide buffers in the form of landscaping, screens or walls to limit impacts to adjacent land uses, keeping in mind *crime prevention through environmental design (CPTED)* principles to ensure that the area where the garbage facilities are located is safe.

## 3.2 Industrial Sites

### 3.2.1 Design Industrial Sites for Safe and Efficient Movement of Trucks

Industrial sites, and areas including manufacturing, warehousing, distribution centres or major freight transportation facilities, are an important part of any community. Industrial sites should be designed with a consistent quality so as to complement the surrounding community.

Within the industrial site, design must consider:

- Access to the loading dock yard;
- Staging area with storage length for trucks queuing to access the loading dock yard;
- Sidewalks for *pedestrians* away from the path travelled by trucks and other vehicles;
- Separate truck access or truck-only designated areas; passenger cars should be parked away from the loading area;
- Adequate space for truck turning manoeuvres;
- Sufficient space to accommodate the expected number of trucks;
- Landscaping and buffering to ensure that the noise of trucks and lighting of the yard do not impact surrounding land uses;
- Height clearances; and
- Security considerations.

*Figure 3.6: Industrial site*

Industrial sites often incorporate some office space in addition to the production/warehouse facilities. Note the white wall and trees that act as a buffer between the office space and loading dock yard.



### Industrial Site Design Strategies

<b>Scope:</b>	<b>Settlement size:</b>	<b>Setting:</b>
Site	All	All
<b>Required resources:</b>	<b>Land type:</b>	
<b>\$ - \$\$\$</b>		

**Complementary Guidelines:**

- 2.2 Protecting Employment Areas and Freight Facilities, specifically Guidelines 2.2.4 and 2.2.5
- 2.4 Improved Integration of Transportation and Land Use Planning, specifically Guideline 2.4.1
- 4.1 Access and Intersections, specifically Guidelines 4.1.1, 4.1.2, 4.1.3, and 4.1.6
- 4.4 Requirements, By-Laws, Policies, and Practice, specifically Guideline 4.4.3

- a. Locate buildings on-site to balance truck access requirements and urban design impacts. In more urban areas, the front of the building may need to be located close to the street to meet the setback distance of surrounding buildings and to facilitate pedestrian and cyclist access, as outlined in the municipal zoning by-law.
- b. Establish design standards that take into account local colour schemes, building materials, building mass and height, architecture, landscaping and character of the surrounding community.
- c. Provide green spaces, landscaped strips or noise walls between industrial parks and sensitive land uses.
- d. Locate loading docks and garbage pick-up areas away from sensitive land uses and away from the street to reduce visual and noise impacts.
- e. Locate buildings that require fewer freight movements (such as offices) closer to adjacent sensitive uses in order to block the visual, noise and other impacts from buildings with busier loading docks (such as warehouses).
- f. Locate access roads that will accommodate large volumes of freight traffic away from adjacent sensitive uses.
- g. Consider including land berms to reduce impacts of light on surrounding land uses.

Figure 3.7: Example of industrial site design

The industrial site design provides multiple bays for loading docks. Spaces have been reserved for small trucks to park and access the building. These spaces are located so that the deliveries can be made without crossing the loading bays.

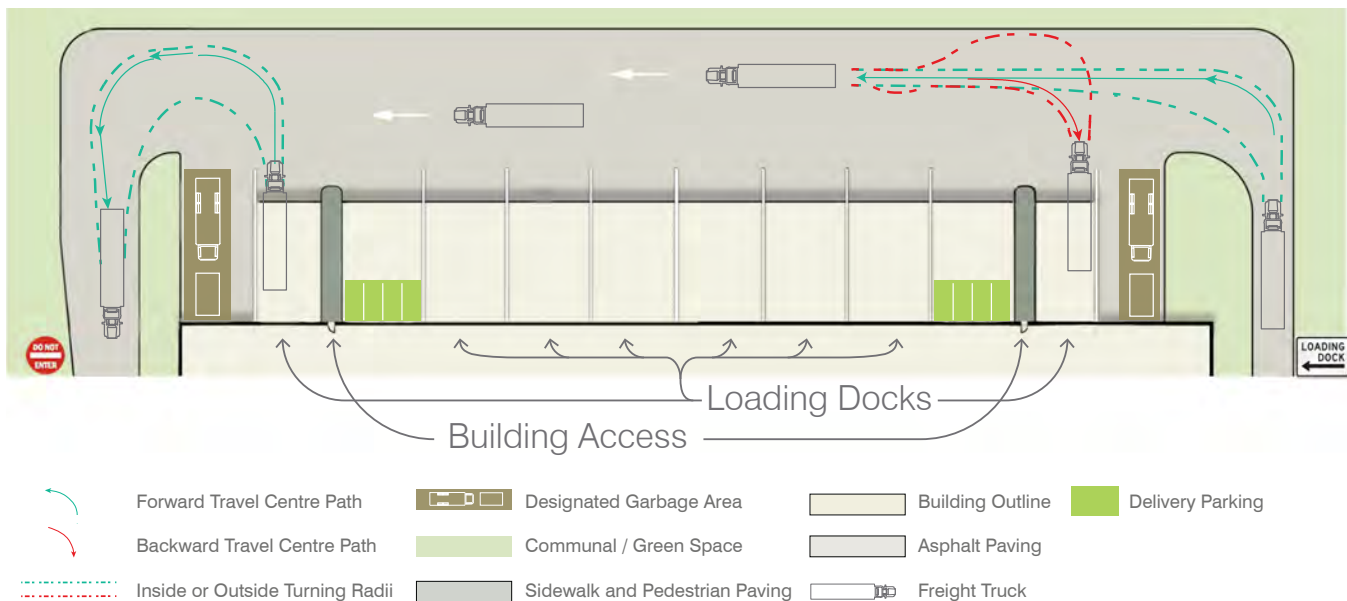



### 3.2.2 Rail-Served Industrial Parks

Provision for access to multiple modes of transportation can be an advantage for industries locating in industrial parks. When planning the road network in a proposed industrial park that will be served by rail, it is important to lay out the roads in such a way to avoid the requirement for road/rail crossings, in order to create efficient and safe access for both rail and trucks to the industrial park. Site layout for an industrial building adjacent to a railway siding should incorporate sufficient setback from the railway property line to accommodate both a fire access route and a railway siding. This provision allows for the possibility for shipping by rail from the building in the future. Additionally, rail-specific requirements such as the design of rail car loading/unloading docks or apparatus, track curvature and the maximum gradient for the track on a private siding should be considered.

#### Rail-Served Industrial Park Site Design Strategies

- When designing freight handling facilities that incorporate rail, separate the movements of rail and trucks for safety and efficiency.
- Locate main track switches for private sidings in such a way that switching activities for the private siding do not block road/rail level crossings.
- Discuss rail car loading/unloading docks or apparatus, track curvature and maximum gradient on private sidings as well as clearances for rail operations with a Railway Industrial Development Representative.
- Dialogue with rail industry representatives (Railway Industrial Development Representative and/or Network Strategy Representative) when planning in proximity of rail lines.

<b>Scope:</b>	<b>Settlement size:</b>	<b>Setting:</b>
Site	All	All
<b>Required resources:</b>	<b>Land type:</b>	
\$ - \$\$\$		

#### Complementary Guidelines:

- 2.3 Planning for the Freight Movement Network, specifically Guideline 2.3.6
- 4.2 Corridors, specifically Guideline 4.2.1
- 4.3 Freight Gateways, specifically Guidelines 4.3.1 and 4.3.2

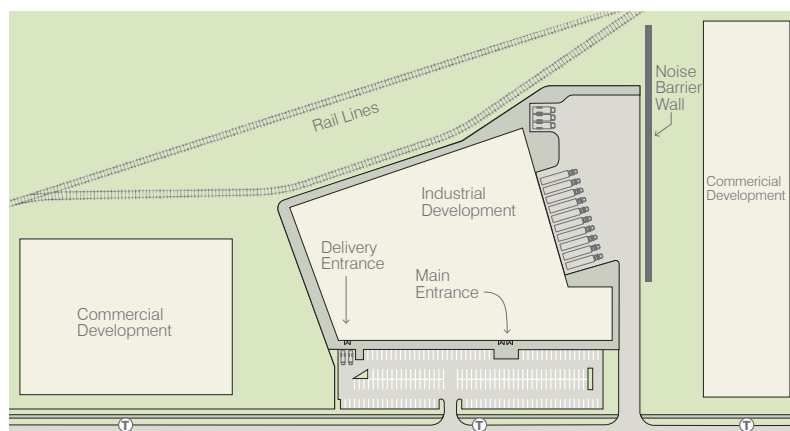





Figure 3.8: Example of rail-served industrial park site design

	Communal / Green Space
	Sidewalk and Pedestrian Paving
	Building Outline
	Asphalt Paving
	Freight Truck
	Transit Stop

## 3.3 Office Sites

### 3.3.1 In the site design process, consider the types of courier, delivery and freight vehicles expected

Figure 3.9: Office site with recessed loading dock



The loading dock has been recessed, partially beneath the back of the building at this office site in Manchester, United Kingdom.

Office land uses often include ground floor commercial businesses such as restaurants, banks, and services, including dry cleaners and small retail shops. These commercial businesses will receive regular deliveries from trucks.

Locating truck-related facilities in the rear of the office building allows the truck activity to occur uninterrupted. Landscaping, walls and other types of screening options along with signage allows these activities to function properly while maintaining the character of the office building and surrounding community.

### Office Site Strategies

<b>Scope:</b>	<b>Settlement size:</b>	<b>Setting:</b>
Site		
<b>Required resources:</b>	<b>Land type:</b>	
\$ - \$\$\$		

#### Complementary Guidelines:

- 2.2 Protecting Employment Areas and Freight Facilities, specifically Guidelines 2.2.4 and 2.2.5
- 2.4 Improved Integration of Transportation and Land Use Planning, specifically Guideline 2.4.1
- 4.1 Access and Intersections, specifically Guidelines 4.4.1, 4.1.2, 4.1.3, and 4.1.6

Figure 3.10: Landscaping utilized to screen loading area



A tiered landscaped *berm* shields the loading dock at this office building from vehicles and *pedestrians* on the street level.

- a. Include infrastructure elements specific to office needs such as parking for mail and courier services, utility vehicles, garbage trucks, paper shredder vehicles and the delivery vehicles of office supplies, retail goods and foodstuffs (for retail shops, cafeterias and eating establishments present in office buildings).
- b. Screen loading docks, garbage collection facilities and outdoor staging areas from the public view by using landscaping, *berms*, walls, fences or screens (see [Figure 3.9](#), [Figure 3.10](#) and [Figure 3.11](#)).
- c. Consider indoor loading bays or enclosed loading docks that completely shield the loading facilities from public view.
- d. Design freight accesses to facilitate truck movement and the movement of other vehicles, transit, cyclists and *pedestrians* (see [Figure 3.12](#)).
- e. Provide signage directing trucks on the appropriate route to access the delivery and loading dock area (see [Figure 3.13](#)).
- f. In locations where office buildings are adjacent to each other, consider locating loading dock facilities in a central location in order to limit the number of facilities that need to be provided as well as maximize the efficiency of the final delivery of the goods.
- g. Locate courier or short-term parking away from loading spaces intended for larger deliveries.
- h. Provision should be made for direct access and presence of truck-trailers even if use is infrequent.
- i. Spaces for couriers can either be allocated in dedicated parking areas and/or where community patrons park. These spaces could be provided in underground lots and should be located near elevators.

Figure 3.11: Appropriate use of wall screens



A wall screens the parking lot from the loading dock at this office building.

Figure 3.12: Loading docks separate from the parking areas



The loading dock yard and the parking area have been segregated at this office building. Signage directs drivers to the appropriate location.

Figure 3.13: Signage used to direct deliveries to the designated areas

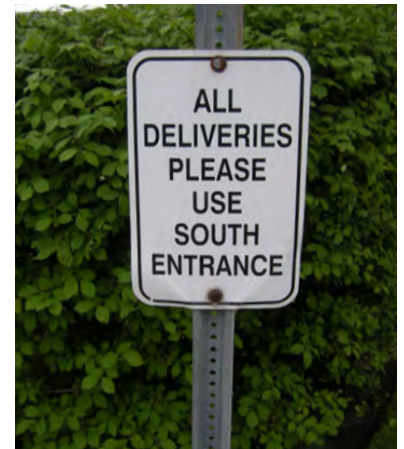

Signage directs delivery vehicles to their designated delivery area.

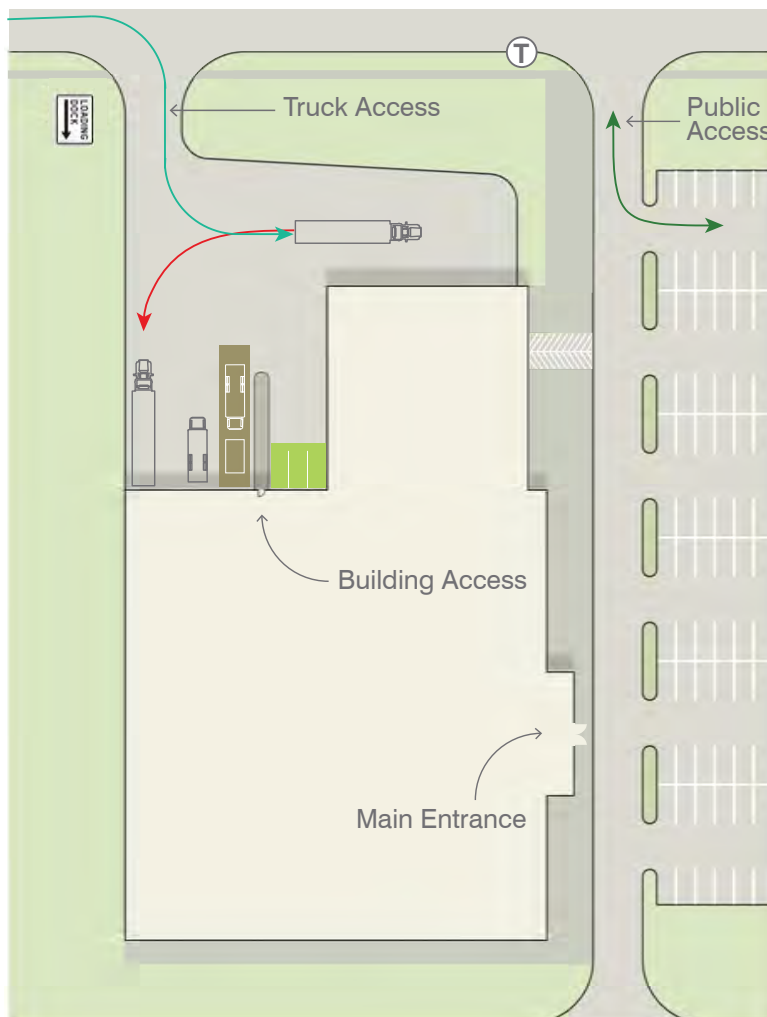











Figure 3.14: Example of office building site design

Separate access has been provided for trucks at this office building. Parking for small trucks has been located so that deliveries can be made without crossing the loading docks. Designated space for garbage facilities is also provided.

-  Forward Travel Centre Path
-  Backward Travel Centre Path
-  Designated Garbage Area
-  Communal / Green Space
-  Sidewalk and Pedestrian Paving
-  Building Outline
-  Asphalt Paving
-  Freight Truck
-  Delivery Parking
-  Two Way Vehicular Access
-  Underground Parking
-  Transit Stop

## 3.4 Retail Sites

### 3.4.1 Retail sites should balance truck access with access for other site users

Existing urban situations are discussed in more detail in Guideline 3.7.

Retail sites, such as shops and restaurants, are found in all communities. They may be clustered in the centre of downtowns or at intersections in rural areas. For general retail sites, loading dock facilities are best located in the rear of these sites. Based on the available space, a designated loading area may be provided in front of the retail site. The retail site design should always consider the primary routes for customers arriving by foot, bike, automobile, or transit vehicle. Truck traffic should be routed in a way that facilitates access for trucks and customers.

#### General Retail Strategies

<b>Scope:</b>	<b>Settlement size:</b>	<b>Setting:</b>
Site	All	All
<b>Required resources:</b>	<b>Land type:</b>	
\$ - \$\$\$		

#### Complementary Guidelines:

- 2.2 Protecting Employment Areas and Freight Facilities, specifically Guidelines 2.2.4 and 2.2.5
- 2.4 Improved Integration of Transportation and Land Use Planning, specifically Guideline 2.4.1
- 4.1 Access and Intersections, specifically Guidelines 4.1.1, 4.1.2, 4.1.3, and 4.1.6
- 4.4 Requirements, By-Laws, Policies, and Practice, specifically Guideline 4.4.3

- a. Encourage truck deliveries to be made during off peak shopping and dining hours to facilitate better access for trucks and automobiles, transit, cyclists and *pedestrians*.
- b. Separate truck accesses from main *pedestrian*, cyclist and transit accesses.
- c. Design any on-site truck accesses to facilitate truck movement with sufficient cross-sections, lane widths and curb radii, and with direct connections from the main street network to the loading dock and delivery points.
- d. Loading docks should be located at the back of the building or on the side, away from the main road frontage and away from the main *pedestrian* entrance.
- e. Provide buffers in the form of landscaping, screens or walls to reduce the visual, noise and light impact from adjacent land uses (see [Figure 3.15](#)).
- f. Separate truck parking from private automobile parking.
- g. Provide parking in the loading dock area for longer trucks in order to properly accommodate the types of vehicles that will service a facility. Pull through spaces may be an appropriate application for longer trucks.

*Figure 3.15: Appropriate screening*

Trees and a fence provide screening of the access to a retail loading dock yard from surrounding residential land uses.

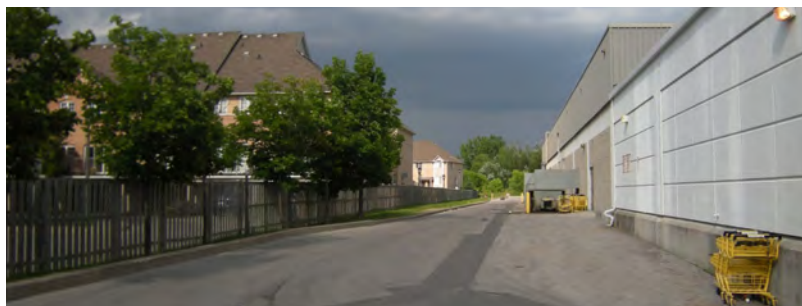

### 3.4.2 At big box shopping centres, balance the mobility of trucks with other access elements

*Big box retail* centres and power centres typically feature home improvement stores, grocery stores, restaurants and retail outlets selling a wide variety of consumer goods (see [Figure 3.16](#)). These centres are especially common in suburban communities in Ontario but are seen province wide in all types of communities. Large retail centres need to be serviced by trucks on a regular basis. It is important that the mobility of trucks be balanced with the many customers on the site.

#### Big Box Shopping-Specific Strategies

- a. Designate truck accesses and truck parking through signage. If a specific area is designated for truck access only, provide appropriate signage and pavement markings, such as a “Trucks Only” sign.

*Figure 3.17: Separate access for trucks servicing a big box retail shopping centre*

A separate access point is provided for trucks to service a *big box retail* centre. The access point from the external road network is located at the rear of the building, away from customer access.



*Figure 3.16: Example of big box retail*



*Big box retail* stores, such as large grocery stores, need to have adequate loading dock facilities located in the rear of the building away from main pedestrian routes.

<b>Scope:</b>	<b>Settlement size:</b>	<b>Setting:</b>
Site		
<b>Required resources:</b>	<b>Land type:</b>	
\$		

#### Complementary Guidelines:

- 2.2 Protecting Employment Areas and Freight Facilities, specifically Guidelines 2.2.4 and 2.2.5
- 2.4 Improved Integration of Transportation and Land Use Planning, specifically Guideline 2.4.1
- 4.1 Access and Intersections, specifically Guidelines 4.1.1, 4.1.2, 4.1.3, and 4.1.6
- 4.4 Requirements, By-Laws, Policies, and Practice, specifically Guideline 4.4.3

### 3.4.3 For indoor shopping malls, locate loading docks and freight facilities away from main pedestrian entrances

Some indoor shopping malls provide *pedestrian* access for customers from all sides. For these facilities, it is important to identify loading areas and truck access routes. Screening and buffers around the loading dock area should be provided, separated from identified *pedestrian*, cyclist and transit access to the shopping mall. The loading docks should be located on the side opposite the main road that the retail facility is located on, keeping in mind that this opposite side may be adjacent to residential neighbourhoods or *sensitive land uses* that will require proper buffering from the loading dock area.

Figure 3.18: Appropriate screening

At an indoor shopping mall, this loading dock is hidden from the parking lot and is located away from major pedestrian access points. Hiding the loading dock provides natural walls that shield the loading dock from view on three sides. At the same time, *crime prevention through environmental design (CPTED)* principles must be considered to ensure that this loading dock, while partially concealed, remains safe.



### Indoor Shopping Mall-Specific Strategies

<b>Scope:</b>	<b>Settlement size:</b>	<b>Setting:</b>
Site		
<b>Required resources:</b>	<b>Land type:</b>	
\$ - \$\$\$		

#### Complementary Guidelines:

- 2.2 Protecting Employment Areas and Freight Facilities, specifically Guidelines 2.2.4 and 2.2.5
- 2.4 Improved Integration of Transportation and Land Use Planning, specifically Guideline 2.4.1
- 4.1 Access and Intersections, specifically Guidelines 4.1.1, 4.1.2, 4.1.3, and 4.1.6
- 4.4 Requirements, By-Laws, Policies, and Practice, specifically Guideline 4.4.3

- a. Provide designated curbside spaces for delivery vehicles near the entrances to indoor shopping malls, paying special attention if there are financial institutions in the mall that require access by security vehicles.
- b. In facilities where customers access the building from all sides, consider enclosing the loading dock yard or providing the loading dock facility on lower levels in order to shield the area from public view, keeping in mind the height clearance requirement for front end loading garbage trucks.

### 3.4.4 At strip mall shopping centres, locate loading, garbage collection and outdoor staging areas to minimize visual impact

Retail strip mall shopping centres, home to shops and restaurants, have many of the same issues as large, *big box retail* centres, on a smaller scale. Strip mall shopping centres need to be serviced by trucks on a regular basis. In new strip malls, provision for trucks should be provided in the rear of the building. In some existing urban cases, loading in the rear of the building may not be available and trucks may need to be accommodated on-street or in the front parking area.

#### Strip Mall Shopping Mall-Specific Strategies

- a. Centrally locate any shared loading dock facilities in order to limit the number of facilities that need to be provided. Doing so can increase the efficiency of the final delivery of the goods to the appropriate shop or area of a store. Ensure direct access to each store if a loading area is being shared.

<b>Scope:</b>	<b>Settlement size:</b>	<b>Setting:</b>
Site		
<b>Required resources:</b>	<b>Land type:</b>	
\$ - \$\$\$		

Figure 3.19: Shared loading dock facilities at a strip mall



Multiple retail shops utilize the loading dock at this strip mall.

#### Complementary Guidelines:

- 2.2 Protecting Employment Areas and Freight Facilities, specifically Guidelines 2.2.4 and 2.2.5
- 2.4 Improved Integration of Transportation and Land Use Planning, specifically Guideline 2.4.1
- 4.1 Access and Intersections, specifically Guidelines 4.1.1, 4.1.2, 4.1.3, and 4.1.6
- 4.4 Requirements, By-Laws, Policies, and Practice, specifically Guideline 4.4.3

## 3.5 Residential Sites

### 3.5.1 Design multi-family residential buildings to permit access by delivery trucks and garbage trucks in a designated area away from the main building access

Multi-family residential units, especially those contained in one building such as an apartment building or condominium tower, should be located in areas where there are convenient *multimodal transportation* connections for passengers and need to be designed to accommodate garbage trucks, postal trucks, courier vehicles, service vehicles, and moving vans. Depending on the amenities within the building, additional trucks may need to be accommodated to service pools or spas or to deliver housekeeping supplies. A discrete area set aside for the type of trucks expected at a residential building will allow these trucks to deliver their services efficiently. This is particularly important for residential buildings that have a ground floor retail function where daily deliveries are expected. Along major corridors it may be possible to accommodate delivery vehicles between adjacent buildings.

Figure 3.20: A dedicated access for trucks



A dedicated access road has been provided for trucks at this high rise residential apartment building. Fences partially screen the garbage area and access to the freight elevator.



## Residential Site Strategies

- Indicate with signs the route for delivery trucks and garbage trucks to access the designated delivery area.
- Provide designated delivery truck parking in the delivery area.
- For residential buildings with freight elevators, locate the delivery area and truck parking adjacent to this elevator for convenient delivery of goods. Courier parking should be available near the main residential entrance.
- Screen the designated delivery truck area with landscape, walls or screens (see [Figure 3.20](#)).
- Consider internal delivery areas in buildings with underground parking, keeping in mind the vertical clearance requirements of front end loading garbage trucks.
- Sufficient vertical and horizontal clearances for trucks should be provided.

<b>Scope:</b>	<b>Settlement size:</b>	<b>Setting:</b>
Site		
<b>Required resources:</b>	<b>Land type:</b>	
\$ - \$\$\$		

### Complementary Guideline:

2.4 Improved Integration of Transportation and Land Use Planning

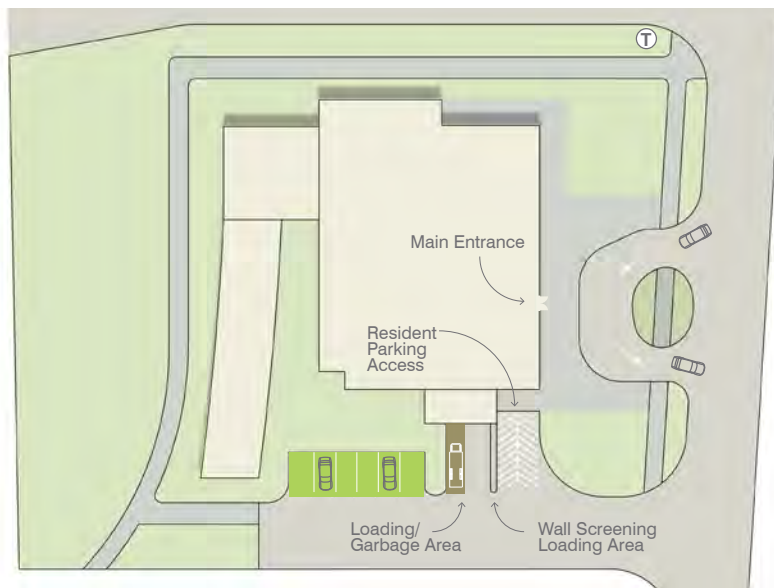

*Figure 3.21: Example of residential site design*

Residential parking is provided under this building, with a designated loading and garbage area at the ground level. Parking is also provided for delivery vans and small trucks.

	Designated Garbage Area
	Communal / Green Space
	Sidewalk and Pedestrian Paving
	Delivery Parking
	Building Outline
	Asphalt Paving
	Underground Parking
	Transit Stop

## 3.6 Institutional Sites

### 3.6.1 Accommodate trucks and *pedestrians* on sensitive institutional use sites

Institutional land uses, such as schools and hospitals, need proper site design to minimize interaction between trucks and *pedestrians*. Schools with cafeteria facilities may have regular truck movements bringing foodstuffs. Garbage trucks also will make regular visits to schools. Hospitals may have a number of truck movements bringing foodstuffs, linens and medical supplies, and may have separate garbage truck movements for regular and biohazardous wastes.

On site, truck access should be clearly defined and loading docks located at the rear of the facility away from any expected *pedestrian* movements. Enclosing the loading dock yard at school facilities would help to prevent students from loitering in these areas. The garbage facilities should be included in any enclosed loading dock yard for the same reason. All of these efforts will help ensure the safety of sensitive users on these sites while still maintaining truck access for deliveries.

Figure 3.22: A hospital – example of an institutional site

Hospitals are serviced by garbage trucks, hazardous waste trucks, delivery vehicles and other types of service trucks.



### On-Road Institutional Site Strategies

<b>Scope:</b>	<b>Settlement size:</b>	<b>Setting:</b>
Site	All	All
<b>Required resources:</b>	<b>Land type:</b>	
\$ - \$\$\$		

#### Complementary Guidelines:

- 2.4 Improved Integration of Transportation and Land Use Planning, specifically Guideline 2.4.1
- 4.1 Access and Intersections, specifically Guidelines 4.4.1, 4.1.2, 4.1.3, and 4.1.6
- 4.2 Corridors, specifically Guideline 4.2.1

- a. Locate schools and hospitals away from truck routes and truck access.
- b. Where schools or hospitals are located on truck routes, post signs alerting drivers of the facility. Reduce speed limits near schools and hospitals and work with local law enforcement agencies to enforce the speed limits. Provide *pedestrian* crossing paths and crossing signals at key *pedestrian* desire points.

### On-Site Institutional Site Strategies

- Clearly identify truck access routes and separate them from main *pedestrian* and cyclist routes.
- Provide truck parking away from main *pedestrian* access points to buildings.
- Locate delivery areas at the rear of the facility, away from any expected regular *pedestrian* activity.
- Screen loading dock areas to reduce the impacts of the noise and emissions from the trucks. When possible, enclose loading dock areas and garbage facilities, especially at schools, to reduce the occurrence of accidents.

**Scope:**                      **Settlement size:**                      **Setting:**

Site                                      All                                      All

**Required resources:**                      **Land type:**

\$ - \$\$\$



**Complementary Guidelines:**

- 2.4 Improved Integration of Transportation and Land Use Planning, specifically Guideline 2.4.1
- 4.1 Access and Intersections, specifically Guidelines 4.1.1, 4.1.2, 4.1.3, and 4.1.6
- 4.2 Corridors, specifically Guideline 4.2.1

*Figure 3.23: Example of institutional (hospital) site design*

Separate access for trucks has been provided. The loading dock has been situated away from the ambulance access and away from patient access points. Deliveries by large and small trucks are accommodated.



## 3.7 Site Design to Support Freight Mobility in Existing Urbanized Areas

### 3.7.1 Improve truck movements to allow for the efficient and safe flow of goods into and out of the area

Figure 3.24: Truck turning on a narrow street



This truck is having difficulty making a turn on a narrow street.





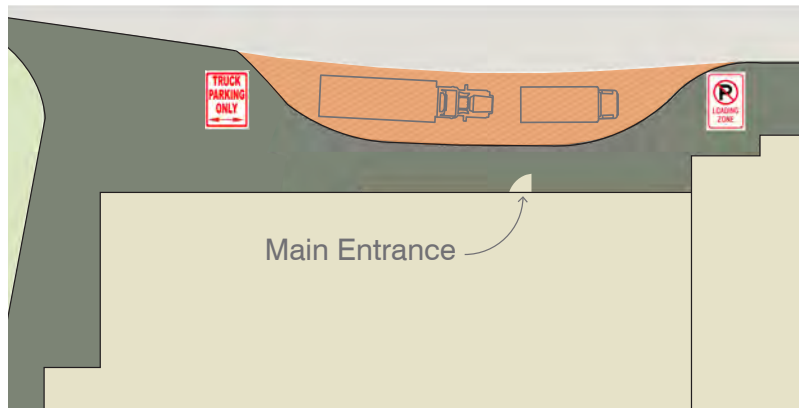

Individual retail shops, strip malls and mixed use developments in more urbanized areas all require freight, courier and garbage services in order to function effectively. Recognizing that just-in-time and next day delivery require deliveries throughout the day is an important consideration when planning for improvements in existing urbanized areas.

Freight movements in historic downtowns sometimes face the added challenge of physical impediments on mobility (see Figure 3.24). Narrow streets and laneways in these areas can be difficult for trucks to move through due to tight curb radii and narrow right-of-way widths. Smaller delivery vehicles should be considered in these circumstances. High density areas do provide the opportunity for shared facilities. Some locations may be well suited to utilize a centrally located loading dock.

Figure 3.25: Example of site design in existing urban area

A designated loading zone has been provided on-street to service this development in an urban area.



- |   |                                |   |                  |
|---|--------------------------------|---|------------------|
|  | Truck Parking Only             |  | Building Outline |
|  | Communal / Green Space         |  | Asphalt Paving   |
|  | Sidewalk and Pedestrian Paving |  | Freight Truck    |

## Existing Urbanized Site Strategies

- Create designated loading zones on-street when space is insufficient for rear loading dock yards (see [Figure 3.26](#)).
- When redesigning street cross-sections, consider providing a loading zone lay-by, keeping in mind the paths likely to be traveled by *pedestrians* and cyclists.
- Avoid the use of lay-bys on streets with defined cycling lanes. Provide these on other streets if possible.
- Where possible, locate loading areas underground, at the rear of buildings, such as in an alleyway or service lane, or accessed from side streets that are not as heavily travelled by *pedestrians* as the main street.
- Provide signage along streets designating appropriate truck accesses (see [Figure 3.27](#)).
- Plan access to avoid conflicts with cyclists and *pedestrians* (including transit stops) by prohibiting truck parking on bike lanes, sidewalks or in transit stops.
- Implement design guidelines for site redevelopment (addressing truck access, waste removal and delivery access), balancing urban design and efficient access.
- Consider freight facilities improvements as part of a community improvement plan.

Figure 3.26: Designated on-street loading area



A designated on-street loading area is provided in this example.

<b>Scope:</b>	<b>Settlement size:</b>	<b>Setting:</b>
Site		
<b>Required resources:</b>	<b>Land type:</b>	
<b>\$ - \$\$\$</b>		

### Complementary Guidelines:

- Protecting Employment Areas and Freight Facilities, specifically Guidelines 2.2.4, 2.2.5, and 2.2.6
- Improved Integration of Transportation and Land Use Planning, specifically Guidelines 2.4.1 and 2.4.3
- Access and Intersections, specifically Guidelines 4.1.1, 4.1.2, 4.1.3, and 4.1.6
- Corridors, specifically Guidelines 4.2.1 and 4.2.2
- Implementation Tools, specifically Guideline 5.2.5

Figure 3.27: Back alley – alternative to on-street loading areas



Providing receiving facilities along back alleyways in urban areas allows trucks to make deliveries without impeding street traffic.

## 3.8 Site Design to Support Freight Movement in New Mixed-Use Areas

Figure 3.28: New mixed-use development containing a grocery store and residential units



New developments offer the opportunity to provide adequate facilities for truck movements.

### 3.8.1 Implement strategies for the efficient and safe flow of goods during the design stage

In new mixed-use areas, loading areas should be discrete and properly screened, and may provide the opportunity for shared loading dock facilities between multiple buildings and multiple land uses. Conflicts between *pedestrians*, cyclists, transit vehicles and private automobiles can be minimized in the design stage by providing separate access points for truck and non-truck users.

New mixed-use areas need to take into account municipal zoning by-laws and relevant guidelines, such as the D-Series Guidelines from the Ministry of the Environment and Climate Change, which provide guidance on the location of *sensitive land uses* in relation to industrial land uses.

### New Mixed-Use Site Strategies

<b>Scope:</b>	<b>Settlement size:</b>	<b>Setting:</b>
Site		
<b>Required resources:</b>	<b>Land type:</b>	
\$ - \$\$\$		

#### Complementary Guidelines:

- 2.2 Protecting Employment Areas and Freight Facilities, specifically Guideline 2.2.6
- 2.4 Improved Integration of Transportation and Land Use Planning, specifically Guideline 2.4.1
- 4.1 Access and Intersections, specifically Guidelines 4.1.1, 4.1.2, 4.1.3, and 4.1.6
- 4.2 Corridors, specifically Guidelines 4.2.1 and 4.2.2

- a. Locate loading areas to separate freight access from *pedestrian* access.
- b. Consider separating freight access from transit and auto access.
- c. Consider truck access on streets with exclusive transit lanes provided that the trucks can park without blocking transit movements.
- d. Designate truck accesses and truck loading/unloading areas using proper signage. Enforce truck loading/unloading areas and truck parking to ensure that trucks do not stay beyond the time permitted and to reduce the likelihood of private vehicles parking illegally in the truck-designated areas.
- e. Consider adding short term drop-off space for couriers, located close to main entrance(s).
- f. Locate freight access to mixed use ground floor establishments to the rear of the building where possible via a service lane way. Where a lane is not feasible, provide access via the front of the building with appropriate setbacks and the use of laybys.
- g. Curbside spaces are needed where there are no off-street loading spaces or service laneways.

## 3.9 Site Design to Coordinate Freight Transportation with Public Transit, Cyclists and Pedestrians

### 3.9.1 Design sites and adjacent roads to facilitate truck movement and transit vehicle/passenger movement

Site design must take into account trucks and their interaction with transit vehicles. Truck parking or loading cannot restrict buses from being able to access their stops. Parked or idling trucks need to be clear of any fixed transit routes, such as streetcars and light rail transit (LRT). At the same time, trucks need to be able to cross transit routes in order to make deliveries on either side of the street. In cases where transit vehicles operate in the median, physically separated from the rest of the traffic, turning lanes for left and U-turns need to be provided so that trucks can access their destinations.

#### On-Road Truck/Transit Strategies

- In the case of physically separate transit lanes in the median of a road, provide left-turn and U-turn lanes at appropriate spacing to enable trucks to cross the transit lane and access sites (see [Figure 3.29](#)).
- Separate transit stops and truck parking areas to avoid conflicts between these vehicles.
- Maintain adequate travel lane widths for trucks.
- Use far side transit stops where possible to accommodate truck turns at intersections and tailor curb radii and intersections to accommodate large truck right turns.

#### On-Site Truck/Transit Strategies

- Separate truck routes and transit vehicle routes to avoid conflicts between these vehicles.
- Locate transit stops and stations away from truck parking and away from the loading dock yard.
- Provide signage on-site to indicate the appropriate pedestrian path to the transit stop.

Figure 3.29: Turning movements permitted across transit lanes in the median of a road

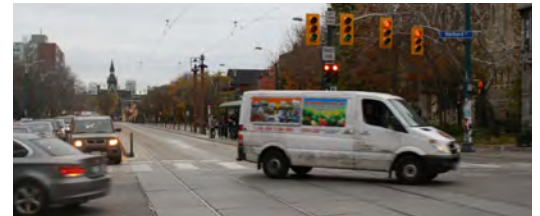

Turn lanes and a left turn signal have been provided to enable trucks and other vehicles to cross transit lanes that are located in the median of the road.

<b>Scope:</b>	<b>Settlement size:</b>	<b>Setting:</b>
Site and Municipal		
<b>Required resources:</b>	<b>Land type:</b>	
\$ - \$\$	All	

#### Complementary Guideline:

- 2.3 Planning for the Freight Movement Network, specifically Guidelines 2.3.5 and 2.3.7

<b>Scope:</b>	<b>Settlement size:</b>	<b>Setting:</b>
Site and Municipal		
<b>Required resources:</b>	<b>Land type:</b>	
\$ - \$\$	All	

#### Complementary Guideline:

- 2.3 Planning for the Freight Movement Network, specifically Guidelines 2.3.5 and 2.3.7

### 3.9.2 Accommodate trucks and cyclists simultaneously in the transport system through the use of separate bicycle facilities

Trucks and cyclists both should be accommodated in site design to ensure safety of travel. Where truck traffic is more common on designated bike routes, providing off-road dedicated bike lanes is the ideal solution to accommodate both trucks and cyclists. In situations where bike lanes are provided on roads that are also truck routes, the bike lanes should be clearly identified and designated with lane and pavement marking, as well as signage.

The separation of cyclists and trucks should continue on-site, with primary bike routes and service driveways separated. Bike parking and loading dock yards should be well removed from each other.

Figure 3.30: Clearly marked bike lane



A dedicated bike lane with clear pavement marking helps a cyclist and truck share the road.

#### On-Road Truck/Cyclist Strategies

- Ensure adequate width of on-street bike lanes.
- Provide bike lane markings, pavement markings and signage to alert vehicle drivers of the bike route (see [Figure 3.30](#)).
- Install truck access signs prior to major truck access points that may be shielded from the view of cyclists.

<b>Scope:</b>	<b>Settlement size:</b>	<b>Setting:</b>
Site and Municipal		
<b>Required resources:</b>	<b>Land type:</b>	
<b>\$ - \$\$</b>	All	

#### Complementary Guidelines:

- 2.2 Protecting Employment Areas and Freight Facilities, specifically Guideline 2.2.4
- 2.3 Planning for the Freight Movement Network, specifically Guidelines 2.3.5 and 2.3.7

The truck access sign is sign WC-8R in the *Manual of Uniform Traffic Control Devices for Canada*.



## On-Site Truck/Cyclist Strategies

- a. Ensure that visibility is maintained at driveways and intersections, providing the most direct bicycle routes possible to prevent cyclists from using routes that may have higher volume freight movement.
- b. Separate truck access routes from bike access routes.
- c. Use signage and pavement markings to indicate on-site bike routes and the location of bike parking. Dedicated bike paths should be uninterrupted and an adequate width to accommodate two-way bike movement.
- d. Locate bike parking close to building entrances to help prevent unwanted parking against trees, wheelchair ramps, utility poles or railings. Locate bike parking in a high visibility area away from the loading dock and any truck parking facilities so that truck drivers and cyclists can see each other clearly and to reduce conflicts between the two.

### Scope:

Site and Municipal

### Settlement size:



### Setting:



### Required resources:

\$ - \$\$

### Land type:

All

### Complementary Guidelines:

- 2.2 Protecting Employment Areas and Freight Facilities, specifically Guideline 2.2.4
- 2.3 Planning for the Freight Movement Network, specifically Guidelines 2.3.5 and 2.3.7

### 3.9.3 Accommodate trucks and *pedestrians* simultaneously in the transport system through appropriate pedestrian facilities

Site design should address the needs of trucks and *pedestrians*. Sidewalks should be provided in urbanized areas to prevent *pedestrians* from walking on the street where trucks and other vehicles operate. On roads with consistent truck traffic, sidewalks should be set back from the roadside curb behind a boulevard to further improve safety. Crosswalks should be striped to draw attention to the presence of *pedestrians* and at traffic light intersections, *pedestrian* crossing signals should be provided, indicating when it is appropriate for *pedestrians* to cross.

While wide intersections are often necessary for truck turns, this can make them less safe for *pedestrians* to cross. When determining necessary lane widths, freight needs should be balanced with *pedestrian* needs. Left turn lanes can be set back from the through and/or right turn lane stop lines in order to reduce curb radii for large turning vehicles. Reducing the curb radii creates more space on sidewalk corners for *pedestrians* and shortens the pavement distance for *pedestrians* to cross at the intersection.

## On-Road Truck/Pedestrian Strategies

<b>Scope:</b>	<b>Settlement size:</b>	<b>Setting:</b>
Site and Municipal		
<b>Required resources:</b>	<b>Land type:</b>	
\$ - \$\$	All	

### Complementary Guidelines:

- 2.2 Protecting Employment Areas and Freight Facilities, specifically Guideline 2.2.4
- 2.3 Planning for the Freight Movement Network, specifically Guidelines 2.3.5 and 2.3.7

- a. Provide a setback from the road for sidewalks and crosswalks along truck routes so that *pedestrians* have a buffer between themselves and vehicle traffic (see [Figure 3.31](#)).
- b. Construct sidewalks to an adequate width to allow two people to walk side by side. Accommodate areas with high *pedestrian* volumes with wider sidewalks.
- c. Where justified by *pedestrian* or vehicular traffic volumes, install traffic signals, crosswalks and *pedestrian* crossing signals at accesses to sites that generate regular truck traffic in order to reduce conflicts between *pedestrians* and vehicular traffic.
- d. Provide road signs alerting of truck turning movements.
- e. Provide road signs alerting drivers of *pedestrian* crosswalks that are at midblock locations away from intersections.

*Figure 3.31: Appropriate setbacks and sufficient sidewalk*

The pedestrian sidewalk is set back from the road to provide a buffer between *pedestrians* and vehicular traffic. Additionally, drivers are alerted through signage of the possible presence of bicyclists.



## On-Site Truck/Pedestrian Strategies

<b>Scope:</b>	<b>Settlement size:</b>	<b>Setting:</b>
Municipal and Site		
<b>Required resources:</b>	<b>Land type:</b>	
\$ - \$\$	All	

### Complementary Guidelines:

- 2.2 Protecting Employment Areas and Freight Facilities, specifically Guideline 2.2.4
- 2.3 Planning for the Freight Movement Network, specifically Guidelines 2.3.5 and 2.3.7

- a. Separate *pedestrian* access routes from truck access routes.
- b. Provide *pedestrian* sidewalks on site to prevent *pedestrians* from having to walk in roadways that may be used by trucks.
- c. Construct curb cuts at *pedestrian* crossings to assist people with strollers, carts or mobility aids.
- d. Avoid designs where truck drivers exiting from driveways cannot see *pedestrians*. If these cases exist, install mirrors on-site to assist truck drivers in seeing *pedestrians* and install an audible signal that will alert *pedestrians* that a truck is approaching.
- e. Provide well-defined *pedestrian* crosswalks across vehicular travel lanes using painted pavement markings, differentiated pavement types and pedestrian-oriented lighting.

## 3.10 Rural Sites

### 3.10.1 Consider the impact freight movements will have on the surrounding rural areas

Site design for freight movements in rural areas should maintain the rural character of the surrounding land uses. Appropriate setback distances from main roads, designated building colours that match the surrounding landscape as well as buffers and landscaping are needed to keep the character and integrate the freight movements with the local community. Signs on main roads may be needed to alert drivers of the possibility of truck movements or farm equipment. Turning lanes on external roads that provide access to rural sites, such as quarries, factories, mining operations, saw mills, large farms or wineries, especially on two-lane roads, will reduce vehicle delay and create a safer environment for goods movement.

#### Rural Site Strategies

- Set back industrial buildings and operations (such as quarries and mining facilities) from the main roads in order to maintain the rural character. Buildings associated with agriculture (i.e., farming, wineries) may add to the rural character and could be located closer to main roads.
- Locate loading areas to separate freight access from *pedestrian* access and ensure continuity of *pedestrian* paths.

<b>Scope:</b>	<b>Settlement size:</b>	<b>Setting:</b>
Site		
<b>Required resources:</b>	<b>Land type:</b>	
\$ - \$\$\$		

Figure 3.32: Example of site design in rural industrial areas

Signage on the external road alerts drivers of the presence of trucks at this rural industrial site. Landscape has been preserved on all sides of the site in order for the site to blend in with the surrounding community and to buffer the site from any nearby *sensitive land uses*.

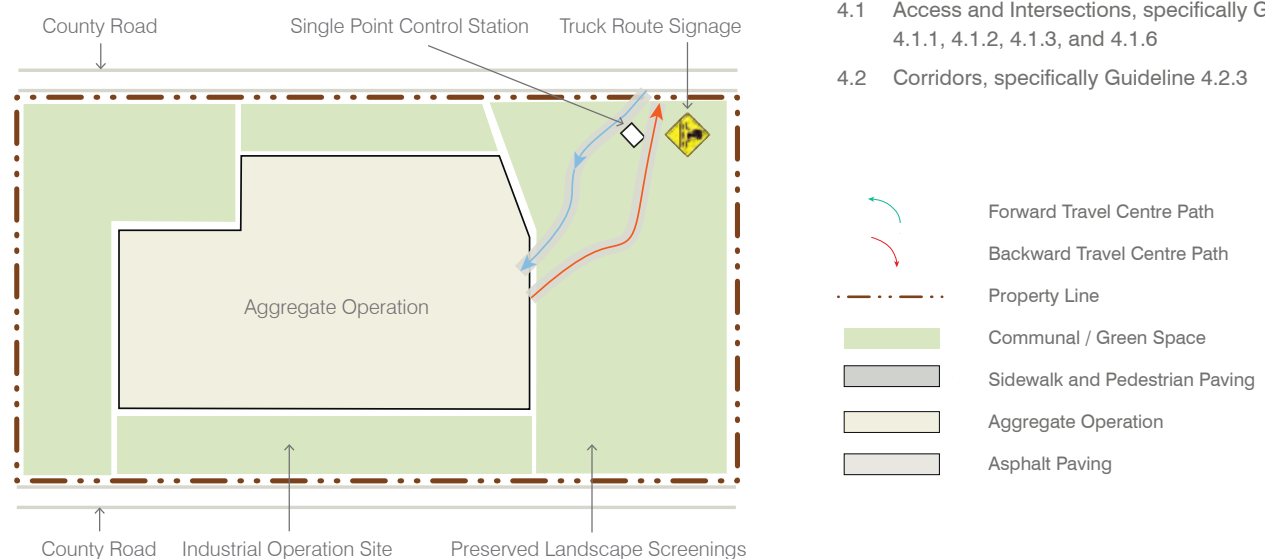

#### Complementary Guidelines:

- Protecting Employment Areas and Freight Facilities, specifically Guidelines 2.2.2 and 2.2.4
- Improved Integration of Transportation and Land Use Planning, specifically Guidelines 2.4.1 and 2.4.2
- Access and Intersections, specifically Guidelines 4.1.1, 4.1.2, 4.1.3, and 4.1.6
- Corridors, specifically Guideline 4.2.3



# 4.0 ROAD DESIGN AND OPERATIONAL GUIDELINES

The road design and operational guidelines are intended to help transportation planners and engineers incorporate freight movement into the design and operation of transportation infrastructure in their municipality.

Guidelines are provided for:

- Access and intersections;
- Corridors; and
- Freight gateways.

Specific requirements, by-laws, policies and practices for effective operations are also addressed.



## Legend

### Scope

Site

District

Municipal

Region

All

Applicable to all

### Settlement size



Small



Medium



Large

All

Applicable to all

### Setting



Rural



Urban

All

Applicable to all

### Required resources



Small



Medium



Large

All

Applicable to all

### Land type



Greenfield



Brownfield



Commercial



Residential

All

Applicable to all



Industrial



Mixed Use



Institutional



Denotes a strategy that supports fuel/energy efficiency or environmental protection.

## 4.1 Access and Intersections

### Truck Acceleration

#### 4.1.1 Design for truck acceleration requirements: Provide adequate infrastructure to accommodate trucks merging with through traffic, and implement traffic control devices that promote truck traffic progression

These Guidelines are intended to help transportation planners and engineers incorporate trucks into the design and operation of transportation infrastructure in their municipality, township or town. The Guidelines were developed to complement the Geometric Design Standards for Ontario Highways developed by the Ministry of Transportation, which also provides guidance on accommodating trucks.

Acceleration rates are lower for trucks than passenger cars, which is a function of weight-to-power ratio and longitudinal road grade. Trucks need more time to pass through intersections and over railroad crossings, and also require longer acceleration lanes to merge with through-traffic. Trucks also have different traffic signal timing needs and can impact traffic progression differently than passenger cars.

#### Strategies for Acceleration at Intersections

- a. Where justified by higher than typical truck volumes, signal timing should be adjusted to be sensitive to truck acceleration requirements, especially when considering the green time for protected left turn phases.
- b. Consider using delay-based *passenger car equivalents (PCEs)* instead of headway-based PCEs to represent trucks when calculating signal timings. Delay-based PCEs, which are more appropriate for intersection operations, are not constant and depend on traffic volume, truck type, and truck percentage.
- c. Provide longer minimum phase times to account for slower truck acceleration and for longer trucks. This also benefits pedestrians by providing longer crossing times.

#### Complementary Guidelines:

- 2.2 Protecting Employment Areas and Freight Facilities, specifically Guidelines 2.2.2 and 2.2.6
- 2.3 Planning for the Freight Movement Network, specifically Guidelines 2.3.2, 2.3.5, and 2.3.7
- 2.4 Improved Integration of Transportation and Land Use Planning, specifically Guidelines 2.4.1, 2.4.2, and 2.4.3
- 3.2 Industrial Sites
- 3.3 Office Sites
- 3.4 Retail Sites
- 3.6 Institutional Sites
- 3.7 Site Design to Support Freight Mobility in Existing Urbanized Areas
- 3.8 Site Design to Support Freight Movement in New Mixed-Use Areas
- 3.10 Rural Sites
- 4.1 Access and Intersections, specifically Guideline 4.1.5
- 4.2 Corridors, specifically Guidelines 4.2.1 and 4.2.2
- 5.2 Implementation Tools, specifically Guideline 5.2.5

Scope:	Settlement size:	Required resources:
Site	All	a. \$ b-c. \$\$
<b>Land type:</b> All		

### Strategies for Acceleration Lanes

**Scope:** Settlement size: Required resources:  
 Site All \$\$

**Land type:**  
 All

**Complementary Guideline:**

4.1 Access and Intersections, specifically Guideline 4.1.5

- a. Provide acceleration lane lengths based on the types of trucks using the facility and their weight-to-power ratios, the truck volume, the through traffic operating speed, the speed of trucks entering the acceleration lane, gear shift delays, and roadway geometry (i.e., percent grade and curvature) (see example in [Figure 4.1](#)).
- b. Consider providing a paved shoulder beyond the end of the striped taper of an acceleration lane (see [Figure 4.2](#)). These extensions should be provided at freeway intersections near industrial areas, where the through traffic speeds are high, and where the acceleration lane is on an upgrade.

*Figure 4.1: Acceleration lane on a major through corridor*



An acceleration lane should be long enough to allow trucks to safely merge into the main traffic stream.

*Figure 4.2: Pavement/shoulder extending beyond the end of the merge/acceleration lane*

Pavement/shoulder widening beyond the acceleration lane provides added safety for trucks that might need more than the standard lane length to merge onto a highway.

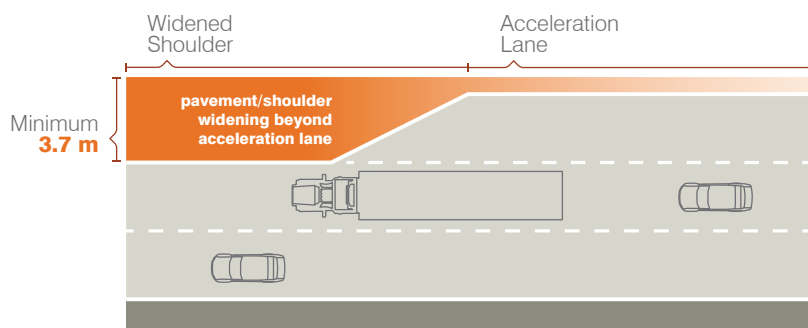



## Truck Deceleration

### 4.1.2 Design for truck deceleration requirements: Provide adequate infrastructure that allows trucks to exit the road without blocking through traffic, and implement traffic control devices that help trucks stop safely

The slowing down of vehicles affects several types of sight distances considered in road geometric design, including stopping sight distance, passing sight distance, decision sight distance, intersection sight distance and railroad-road grade crossing sight distance. All heavy vehicles manufactured after 2001 (and most after 1997) are required to have anti lock brakes which improves stopping distances and control.

Trucks are less manoeuvrable than passenger cars and may require extra decision sight distance at locations where unusual or unexpected movements are required, such as at intersections and interchanges, changes in cross-section, and areas of “visual noise” where roadside signage competes for driver attention. Truck deceleration can also be impacted by liquid cargo loads, particularly when deceleration occurs on a horizontal curve. Liquid sloshing is a minor disturbance for truck drivers when braking on a straight road section and does not affect vehicle performance. However, on curves there is an increase in the chance of rollover by 50%.



#### Complementary Guidelines:

- 2.2 Protecting Employment Areas and Freight Facilities, specifically Guidelines 2.2.2 and 2.2.6
- 2.3 Planning for the Freight Movement Network, specifically Guidelines 2.3.2, 2.3.5, and 2.3.7
- 2.4 Improved Integration of Transportation and Land Use Planning, specifically Guidelines 2.4.1, 2.4.2, and 2.4.3
- 3.2 Industrial Sites
- 3.3 Office Sites
- 3.4 Retail Sites
- 3.6 Institutional Sites
- 3.7 Site Design to Support Freight Mobility in Existing Urbanized Areas
- 3.8 Site Design to Support Freight Movement in New Mixed-Use Areas
- 3.10 Rural Sites
- 4.1 Access and Intersections, specifically Guideline 4.1.3
- 4.2 Corridors, specifically Guidelines 4.2.1 and 4.2.3
- 5.2 Implementation Tools, specifically Guideline 5.2.5

Figure 4.3: Advance traffic signal warning flasher

Advance warning flashers warn trucks that an upcoming traffic signal will soon turn red. These flashers enable drivers to safely decelerate and stop the vehicle prior to reaching the intersection. Similar devices can also be used in advance of at-grade rail crossings.

### Strategies for Deceleration and Stopping at Intersections

- a. Design amber traffic signal phases to accommodate longer and fully-loaded trucks and their associated defined deceleration needs. Also consider all red time (all approaches to traffic signal are red) to allow vehicles to finish their travel through the intersection. Adapting signal operations should be done at locations where data shows trucks are experiencing difficulty stopping during the amber phase or where trucks routinely drive through the red light phase.
- b. Design intersections to be located with enough spacing from railroad tracks to ensure truck vehicles do not extend onto the tracks.

<b>Scope:</b>	<b>Settlement size:</b>	<b>Required resources:</b>
Site, District, and Municipal	All	\$\$
<b>Land type:</b>	All	

## Strategies for Deceleration at Off-Ramps and Curves

<b>Scope:</b>	<b>Settlement size:</b>	<b>Required resources:</b>
Site	All	\$

**Land type:**  
All

### Complementary Guidelines:

- a. 4.1 Access and Intersections, specifically Guideline 4.1.3
- a. 4.2 Corridors, specifically Guidelines 4.2.1 and 4.2.2

- a. Install truck rollover signs or special truck ramp advisory speeds and use special pavement marking patterns to narrow the lane width of both the ramp curve and a portion of the tangent section leading to the curve (see Figure 4.4).

## Strategies for Deceleration on Downgrades

<b>Scope:</b>	<b>Settlement size:</b>	<b>Required resources:</b>
Site	All	\$

**Land type:**  
All

- a. Provide longer stopping sight distances for trucks on downgrades.

*Figure 4.4: Lane narrowing on off-ramp*

Using special pavement marking patterns to narrow the lane width of both the ramp curve and a portion of the tangent section leading to the curve are complementary actions that encourage trucks to decelerate to speeds that are safe for negotiating the curve.

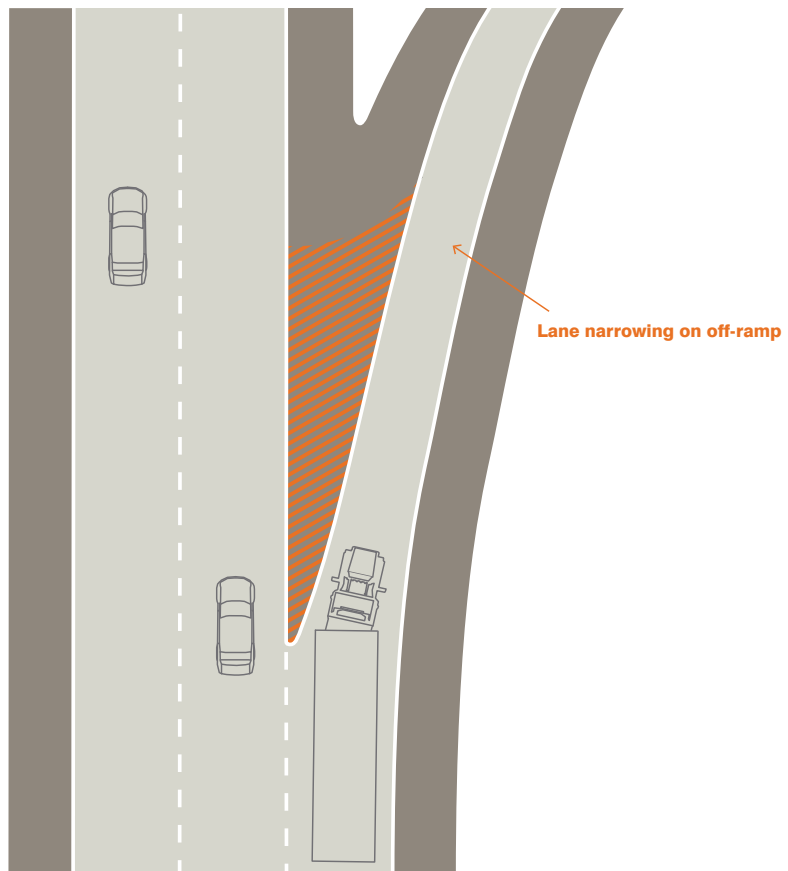

# Truck Turning Movements

## 4.1.3 Accommodate truck turning movements: Design inner turning radii, curb radii at access points, and interchange loop radii to facilitate turning movements of large trucks

The spacings between axles and hitch points and the front and rear overhang distances are the main consideration for truck turning radius, *off-tracking*, and *swept path width*. These characteristics differ by truck type, and should be considered in the design of various road features to accommodate freight movement. In particular, both the overall length and length of truck or trailer are important considerations for turn templates. For a tractor semi-trailer combination, the maximum overall length is 23 metres, while the maximum semi-trailer length is 16.2 metres. For a truck and full trailer, the maximum overall length is 23 metres and the maximum truck length is 12.5 meters.

The physical dimensions of trucks are an obvious and often easily measurable metric to consider in roadway design. However, operational characteristics such as a truck's dynamic stability are much more complicated and difficult to measure, and can be overlooked in the design of horizontal curves and cross-sectional geometry, due to low speed operations in these instances.

In low-speed areas, trucks may require special turning movement considerations, such as at-grade intersections and entrances to freight facilities. In high-speed areas, consideration should be given to interchange ramps and long downgrades terminating with a curve. Accommodating turning trucks at low-speed locations usually requires providing adequate geometry to accommodate swept paths during turns. For high-speed areas, truck stability attributes are often more critical.

### Strategies for Geometric Design

- Provide adequate turning radius by determining the governing length and configuration of trucks along with their associated *off-tracking* and *swept path width* characteristics.
- Use compound curves or simple curves with tapers to accommodate large truck turning radius requirements, which can minimize crossing distance for pedestrians compared to simple curves.
- Use painted edge lines to provide guidance for passenger vehicle turning paths while providing sufficient paved area beyond the edge lines to accommodate the turning path of trucks.

#### Complementary Guidelines:

- Protecting Employment Areas and Freight Facilities, specifically Guidelines 2.2.2 and 2.2.6
- Planning for the Freight Movement Network, specifically Guidelines 2.3.2, 2.3.5, and 2.3.7
- Improved Integration of Transportation and Land Use Planning, specifically Guidelines 2.4.1, 2.4.2, and 2.4.3
- Industrial Sites
- Office Sites
- Retail Sites
- Institutional Sites
- Site Design to Support Freight Mobility in Existing Urbanized Areas
- Site Design to Support Freight Movement in New Mixed-Use Areas
- Rural Sites
- Access and Intersections, specifically Guideline 4.1.4
- Corridors, specifically Guideline 4.2.1
- Freight Gateways, specifically Guidelines 4.3.3 and 4.3.4
- Implementation Tools, specifically Guideline 5.2.5

<b>Scope:</b>	<b>Settlement size:</b>	<b>Required resources:</b>
Site	All	\$
<b>Land type:</b>		
All		

Figure 4.5: Compound curve versus simple curve

A compound curve can result in a shorter walking distance for pedestrians compared to a simple curve.

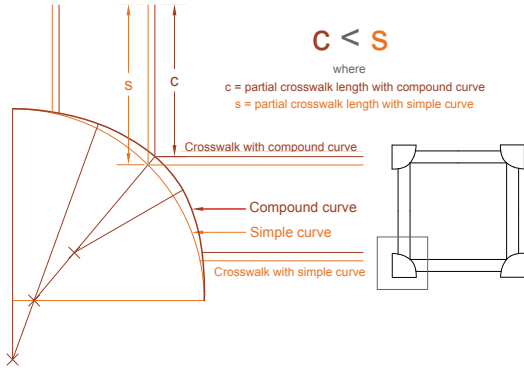

- d. Provide adequate curb return radii for right turns at intersections (see Figure 4.7 for two examples. Some types of trucks, such as LCVs, require a wider swept path than these shown in this example). Determining the appropriate design requires a balance between the needs of all transportation modes. The curb return radius should be large enough to accommodate the *off-tracking* and swept path of the vehicle without encroaching on the curb or other lanes. Consider use of channelized right turn lanes only in situations where this will not conflict with pedestrian priority movement.
- e. Eliminate or offset lateral (side) obstructions at intersections and accesses, such as light standards, signs, poles, and overhanging trees so that truck sight lines are not blocked when making turns (see Figure 4.6).

Figure 4.6: Lateral obstructions that can impede trucks turning

Trucks need adequate lateral and vertical clearance to make turns safely.

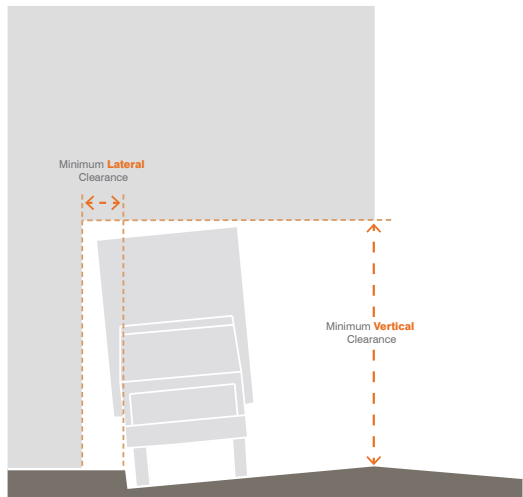
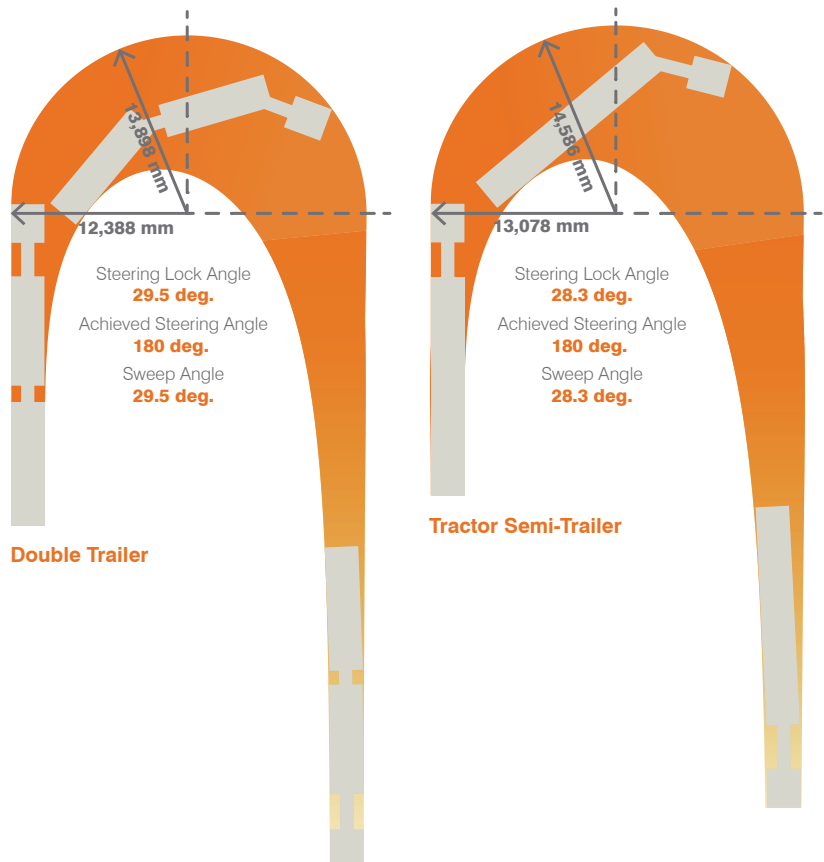

Figure 4.7: Turning template with swept path, off-tracking, and turning radius (side by side comparison of double trailer tractor and tractor semitrailer)

The turning templates of a double trailer and a tractor semi-trailer are illustrated.



## Strategies for Truck Stability

- Consider the changing stability of trucks when designing curves. This may require the designer to determine the necessary dynamic inter-axle load transfer, height of roll center, roll stiffness, roll steer coefficient, compliance steer coefficient, center-of-gravity height, overall weight, and longitudinal and lateral weight distribution for trucks operating on the curve (see Figure 4.8).
- Design horizontal curves such that trucks can operate at the design speed with enough margin of safety against skidding or rolling over. Providing a special truck rollover sign may be needed on curves where physical changes cannot be made to accommodate trucks (see Figure 4.9 and Figure 4.10).

<b>Scope:</b>	<b>Settlement size:</b>	<b>Required resources:</b>
Site	All	\$
<b>Land type:</b>		
		

**Complementary Guideline:**

- 4.2 Corridors, specifically Guideline 4.2.1

*Figure 4.8: Truck operating on reverse super-elevation and the rollover forces acting on the truck*

The figure illustrates the different lateral G forces experienced by the driver and the trailer when on a curve. Although the driver may be comfortable during the turn, the trailer may be at risk of overturning.

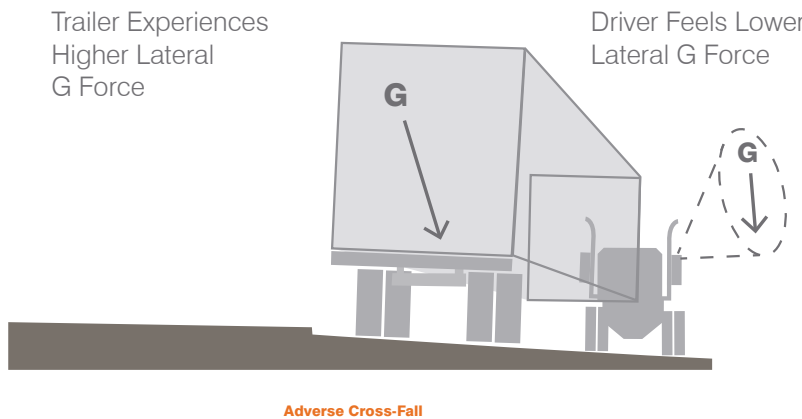

*Figure 4.9: Truck rollover sign at a curve*

This sign warns trucks to operate at a low speed due to the potential to roll over because of a curve in the road. This sign recommends a safe speed for trucks to safely negotiate a curve and avoid rolling over.



*Figure 4.10: Placement of truck rollover sign and detection*

This figure illustrates the placement of the detection mechanism and advisory sign to warn trucks of the potential to roll over.

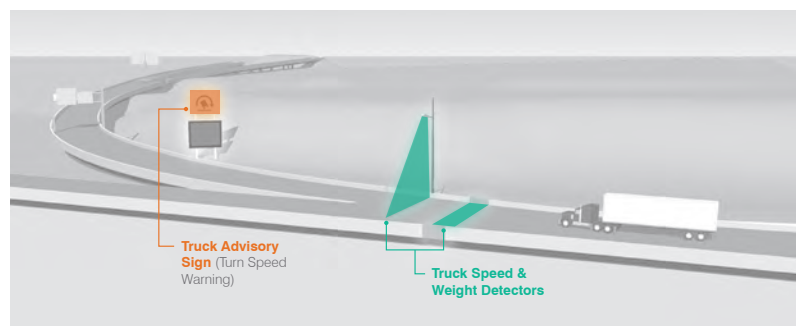

### Strategies for Left-Turns

<b>Scope:</b>	<b>Settlement size:</b>	<b>Required resources:</b>
Site	All	\$
<b>Land type:</b>		
All		

- a. Provide enough storage length at left-turn lanes and consider the presence of longer trucks (see [Figure 4.11](#)).
- b. Where space is available and demands warrant them, consider introducing slotted left-turn lanes to improve sight distance, increase storage and throughput, provide better turning radii, and improve safety. Slotted left-turn lanes should be accompanied with a protected left-turn signal (see [Figure 4.12](#)).
- c. Consider truck acceleration rates and the time needed to clear the intersections when programming the signal timing for left turns.

*Figure 4.11: Plan view of storage lane length for left-turns*

It is important to design left turn bays to be able to accommodate truck turning demand. The length of a left turn storage lane is dependent on left-turn traffic volumes, through traffic volumes, on-coming traffic volumes and the gap between vehicles. The length of turning trucks may also influence the storage length, especially if *long combination vehicles* are present.

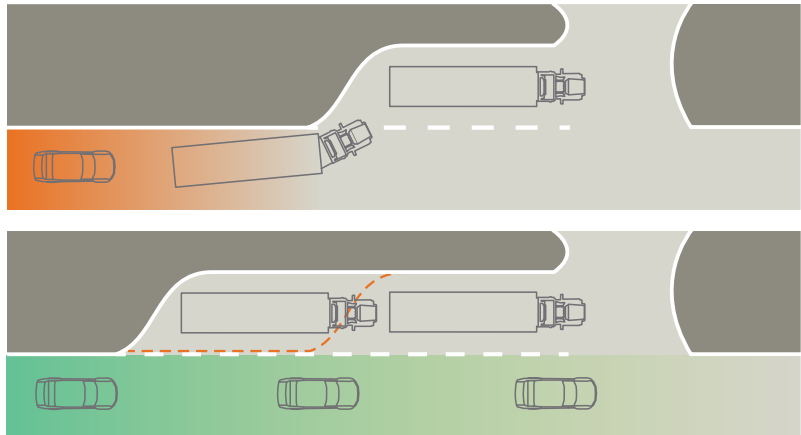

*Figure 4.12: Slotted left-turn*

Slotted left-turns are a useful geometric design feature that help reduce conflicts between left turning vehicles traveling in opposite directions in urban or suburban environments. In addition to benefiting trucks by providing a larger turning radius, they benefit all vehicles by improving sight distance and the potential for wrong-way maneuvers.



### Strategies for Turning Restrictions

<b>Scope:</b>	<b>Settlement size:</b>	<b>Required resources:</b>
Site	All	\$
<b>Land type:</b>		
All		

- a. Ensure that medians on arterial roads do not block direct access to commercial or industrial sites and loading zones.

## Roundabouts and Traffic Circles

### 4.1.4 Design roundabouts and traffic circles to accommodate trucks

Roundabouts and traffic circles can help truck movements by reducing starting and stopping, providing larger turning radii, and improving traffic movement along a corridor. Roundabouts and traffic circles that experience heavy truck traffic should be designed to accommodate the largest vehicles expected, including *Long Combination Vehicles* (LCVs).

On single lane roundabouts, the construction of flat centre islands helps trucks to take left and right turns. On multiple lane roundabouts, flat islands may not be necessary for turning.

#### Strategies for Truck Aprons

- a. Design roundabouts with a flat truck apron as part of the central island, particularly on single-lane roundabouts.

#### Strategies for Striping

- a. Unstriped lanes on multi-lane roundabouts assign responsibility to drivers to position themselves within the roundabout. This provides flexibility for trucks to use the entire roundabout for turning without violating lane discipline expectations from other motorists. Use positive guidance and signage to direct drivers as they enter the roundabout.

#### Complementary Guidelines:

- 2.2 Protecting Employment Areas and Freight Facilities, specifically Guidelines 2.2.2 and 2.2.6
- 2.3 Planning for the Freight Movement Network, specifically Guidelines 2.3.2, 2.3.5, and 2.3.7
- 2.4 Improved Integration of Transportation and Land Use Planning, specifically Guidelines 2.4.1, 2.4.2, and 2.4.3
- 4.1 Access and Intersections, specifically Guideline 4.1.3
- 5.2 Implementation Tools, specifically Guideline 5.2.5

More information about roundabouts can be found at:

<http://www.mto.gov.on.ca/english/engineering/roundabout/index.shtml>

Scope:	Settlement size:	Required resources:
Site	All	\$
<b>Land type:</b>		
All		

Scope:	Settlement size:	Required resources:
Site	 - 	\$
<b>Land type:</b>		
All		

### Strategies for Right Turns

<b>Scope:</b>	<b>Settlement size:</b>	<b>Required resources:</b>
Site	All	\$ - \$\$
<b>Land type:</b>		
All		

- a. The following options are available to accommodate right-turn movements, depending on traffic volumes, truck percentage, and the number of lanes available (see [Figure 4.13](#)):
- i. Allow trucks to use both lanes to make a turn. This is suitable for multi-lane roundabouts with low traffic volumes;
  - ii. For high volume multi-lane roundabouts, or single-lane roundabouts, consider the following:
    - Providing extra turning space with hatching at exit lanes;
    - Constructing right-turn aprons (blisters), keeping in mind *pedestrian* volumes and *pedestrian* safety concerns;
    - Installing by-pass lanes that will accommodate right turning trucks, as well as provide additional right-turn capacity without adding lanes to the roundabout; and
    - Constructing a lane passing through the roundabout (gated pass-through) that is used only when oversize trucks/loads need to pass through a roundabout. The pass through lane would also be useful to maintain traffic during future work on the roundabout or approach roads.

Figure 4.13: Roundabout showing different turning treatments for trucks

Five different turning treatments to design roundabouts for trucks are illustrated.

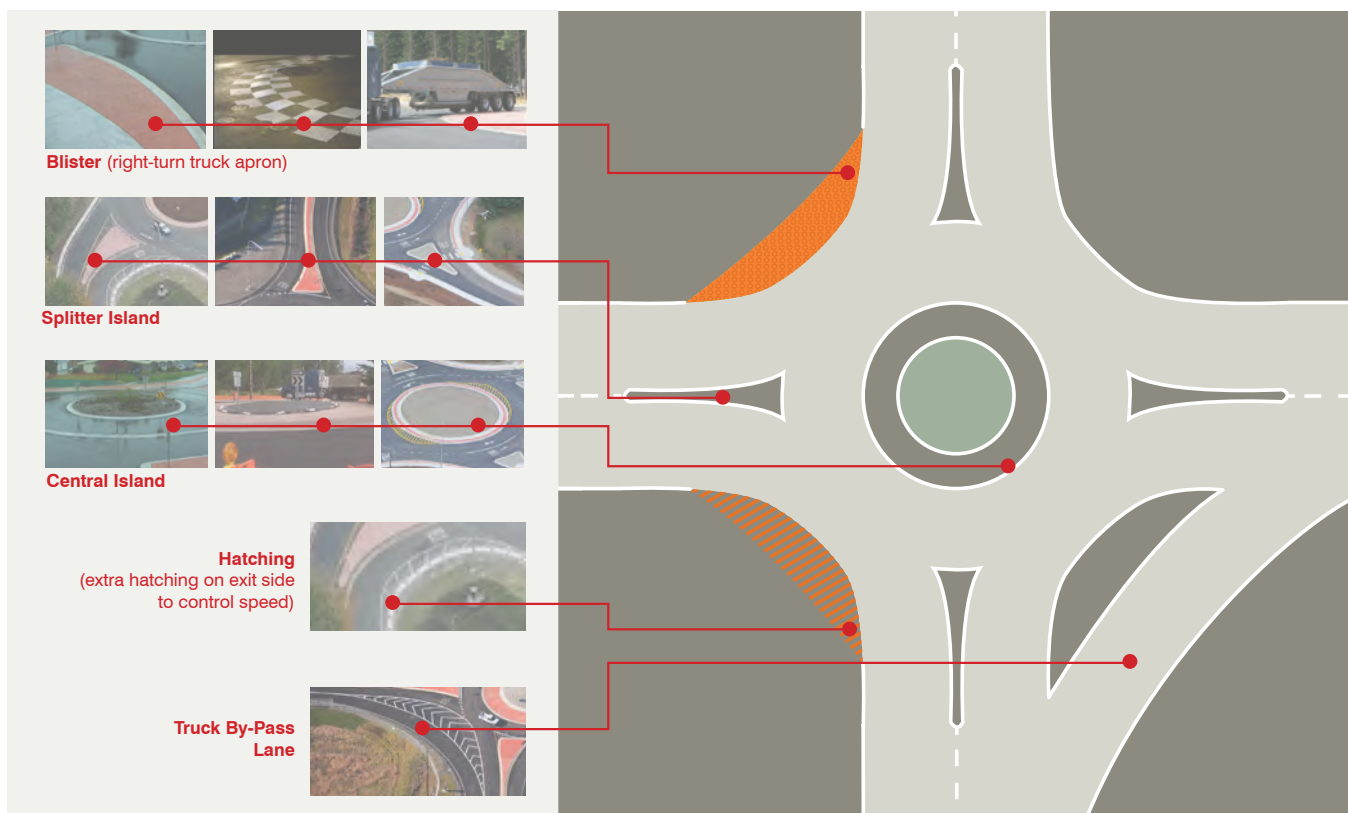



### Strategies for Truck Stability

- a. Consider truck stability characteristics when designing the cross-section of a roundabout. There are two general design options (see Figure 4.14):
  - i. **Crowned:** this option physically separates turning movements, helps with truck movement by reducing the possibility for load shifting/overturning, increases drainage costs since drains are required on both sides of the roadway, and can lower visibility of the central island; and
  - ii. **Sloped:** outward slopes (i.e., sloping down from the central island) increase island visibility and lowers drainage costs but increases the risk of truck rollover. Inward slopes decrease the visibility of the island, decrease the risk of overturning within the roundabout, but can increase truck instability as the truck transitions from the roundabout to the other lanes.
- b. Avoid sudden changes in cross-slopes and ensure good pavement condition since potholes and rutting can increase truck instability on curves.

Scope:	Settlement size:	Required resources:
Site	All	\$
<b>Land type:</b>		
		
a.		
b. All		

Figure 4.14: Roundabout cross-section (crowned - top left image; inward - top right image; outward - bottom images)

The design of the circulating roadway of a roundabout influences the lateral G forces experienced by truck drivers and their trailers.

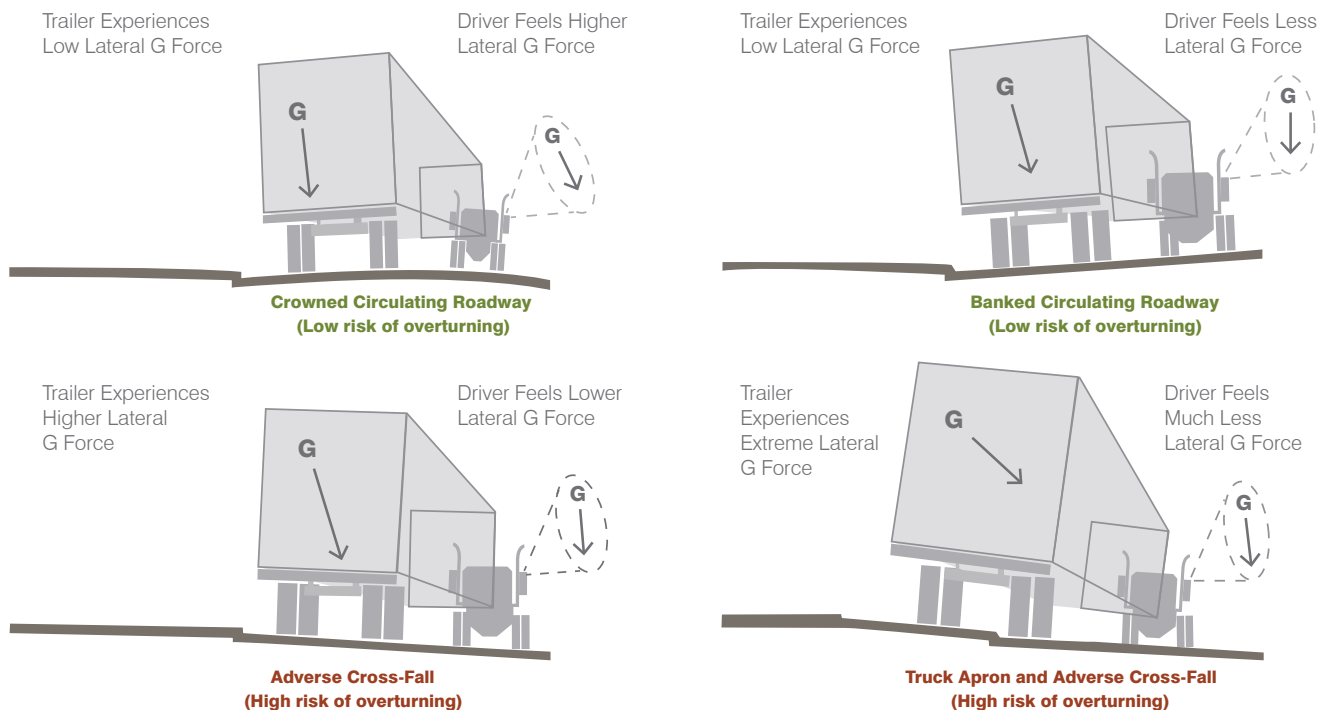

## Strategies for Mini Roundabouts

<b>Scope:</b>	<b>Settlement size:</b>	<b>Required resources:</b>
Site	All	\$
<b>Land type:</b>		
All		

- a. Include special requirements for truck turning movements at mini-roundabouts. Options include:
  - i. Providing a raised, non-crossable splitter island leading up to the mini roundabout if all vehicles can navigate the roundabout without tracking over the island and *pedestrians* frequently use the intersection.
  - ii. Providing a flat central island if vehicles are expected to travel over this island or if the approach has low vehicle speeds (less than 40 km/h). This island should be painted to encourage motorists to circulate around it (see [Figure 4.15](#)).

Figure 4.15: Vehicle driving over centre island of mini roundabout



The painted centre island with no curb is essential for this bus to be able to navigate the roundabout safely. Trucks would operate in a similar fashion in this circumstance.

## Weaving Lanes

### Complementary Guidelines:

- 2.2 Protecting Employment Areas and Freight Facilities, specifically Guidelines 2.2.2 and 2.2.6
- 2.3 Planning for the Freight Movement Network, specifically Guidelines 2.3.2, 2.3.5, and 2.3.7
- 2.4 Improved Integration of Transportation and Land Use Planning, specifically Guidelines 2.4.1, 2.4.2, and 2.4.3
- 4.1 Access and Intersections, specifically Guideline 4.1.1
- 4.2 Corridors, specifically Guideline 4.2.1
- 5.2 Implementation Tools, specifically Guideline 5.2.5



### 4.1.5 Design the municipal *transportation system* to connect effectively with highway interchanges

Weaving occurs when a merge lane is followed closely by an exit lane, requiring vehicles either entering or exiting the freeway to make one or more lane changes. Weaving becomes difficult when traffic volumes are high, speeds are fast, multiple lanes must be crossed, and truck volumes are high. Trucks can have additional difficulty weaving due to lower manoeuvrability, larger blind spots, and in some instances, speed limiting devices. Weaving can lead to bottleneck formation and impact freight mobility, particularly when the weaving section involves a lane drop.

Operational improvements can be used to lower vehicle interaction during weaving, provide additional storage on interchange ramps to accommodate longer queues due to weaving, and reduce safety hazards. Many of the options available for redesigning existing weaving sections to better support trucks are low-cost and relatively easy to implement.

### Strategies for Lane Control

- a. Add an auxiliary lane to connect an on-ramp and off-ramp to reduce weaving movements and increase roadway capacity. This is often effective where interchanges are closely spaced on high-speed roadways.
- b. Extend acceleration and deceleration lanes. This is a low-cost improvement that usually does not require an increase in existing right-of-way area.
- c. Allow trucks to operate in all lanes to create opportunities for lane changes to access off ramps and merge with through traffic.
- d. Install ramp meters in order to lower the amount of traffic on interchange ramps and provide a controlled measure to introduce traffic into a high-speed, high-volume roadway.

Scope:	Settlement size:	Required resources:
a. Site and District	a.  -	a. \$
b-c. Site		b-c. \$\$
	b-c. All	
<b>Land type:</b>		
All		
<b>Complementary Guideline:</b>		
b-c. 4.2 Corridors, specifically Guideline 4.2.1		

## Way-finding

### 4.1.6 Provide way-finding and truck route guidance

Municipalities should establish a truck route network integrated with the neighbouring jurisdictions' networks, and provide clear, consistent, and easily identifiable way-finding tools for truck drivers. Clear, consistent, and easily identifiable signs specific to the needs of trucks can help to create smooth, efficient, and safe truck routing regardless of road network complexity, density, and traffic volumes. General traffic information systems and way-finding signs are also beneficial to trucks.

Way-finding and guidance is especially important for specialized truck movements such as hazardous material transportation and oversize/overweight movements. Positive way finding for these trucks provides a safety benefit for the public by directing trucks with dangerous loads to low-risk roads and ensuring that infrastructure is not damaged due to oversized trucks.

<b>Complementary Guidelines:</b>	
2.2	Protecting Employment Areas and Freight Facilities, specifically Guidelines 2.2.2, 2.2.3, and 2.2.6
2.3	Planning for the Freight Movement Network, specifically Guidelines 2.3.2, 2.3.5, and 2.3.7
2.4	Improved Integration of Transportation and Land Use Planning, specifically Guidelines 2.4.1, 2.4.2, and 2.4.3
3.2	Industrial Sites
3.3	Office Sites
3.4	Retail Sites
3.6	Institutional Sites
3.7	Site Design to Support Freight Mobility in Existing Urbanized Areas
3.8	Site Design to Support Freight Movement in New Mixed-Use Areas
3.10	Rural Sites
4.2	Corridors, specifically Guideline 4.2.1
4.3	Freight Gateways
4.4	Requirements, By-Laws, Policies, and Practice, specifically Guidelines 4.4.1 and 4.4.2
5.2	Implementation Tools, specifically Guideline 5.2.5

## Strategies for Developing Communication Systems

<b>Scope:</b>	<b>Settlement size:</b>	<b>Required resources:</b>
Municipal and Region	👤 - 👤👤	\$\$\$
<b>Land type:</b>		
All		

- a. Implement a truck routing information system that makes use of *Intelligent Transportation Systems (ITS)* technologies to communicate truck routing information obtained from the *freight audit*. Signs, both stationary and changing, should be placed throughout the truck route and give enough warning to trucks to make routing decisions. Online information should be publicized and printed information provided to trucking companies (see [Figure 4.16](#)).

Figure 4.16: Truck route map

The City of Ottawa has prepared an urban truck route map that identifies the roads designated for trucks throughout the city.

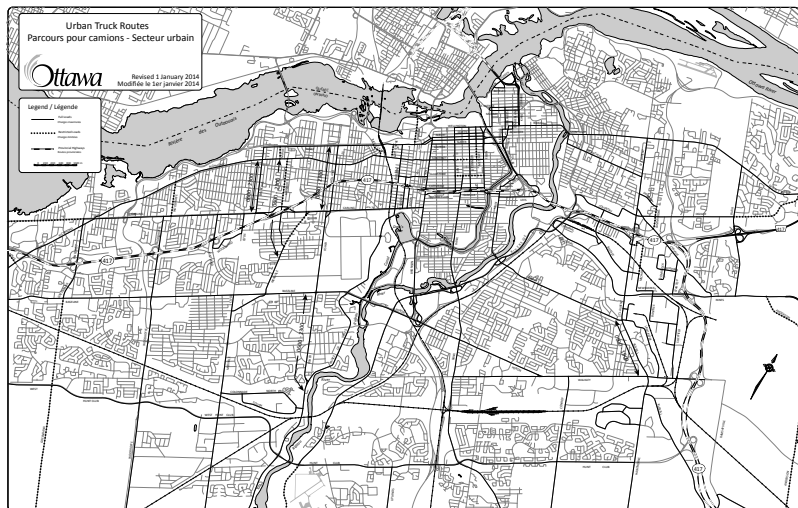

## Strategies for Positive Guidance and Consistent Signing

<b>Scope:</b>	<b>Settlement size:</b>	<b>Required resources:</b>
Municipal and Region	All	\$\$
<b>Land type:</b>		
All		

- a. Design and operate facilities that incorporate a positive guidance approach, where:
  - Signs are placed based on the importance of their information, and to present the driver with information when and where it is needed;
  - Information is given in small amounts to lower the amount given to the driver at one time;
  - There is consistent coding in the color and shape of traffic signs; and
  - Information is repeated to ensure that it is noticed.

See also the Ontario Trucking Association's [Local Truck Routes: A Guide for Municipal Officials](#)

<http://www.omkn.ca/OMKN-Docs/Best-Practices/Beneficial-Reports/111201OTAGuideFINAL.aspx>

## 4.2 Corridors

### Movement along Corridors

#### 4.2.1 Municipalities should plan for safe and efficient movement of trucks along a corridor

Truck movements can be supported along corridors by adding capacity, ensuring that there is enough road geometry, improving signal timing and synchronization, providing road network connections, lowering travel time, and increasing reliability.

An important part of reliable freight transportation is safety. Collisions and accidents are unexpected events and can cause unrecoverable delays, higher insurance costs, equipment imbalances, and lost and damaged cargo.

Designated or principal truck routes have a higher need for special truck considerations than that of a local road. Road geometry should follow the *complete streets* principle to ensure that the road is designed, built, operated and maintained for all road users, including trucks. However, context-sensitive design is an important consideration when planning, designing and operating the overall transportation network.

#### Strategies for Capacity Improvements

- Provide paved shoulders to accommodate truck *off-tracking*.
- Restripe pavement markings to add more lanes. This can add capacity to existing corridors without constructing new infrastructure (see [Figure 4.17](#)).

Figure 4.17: Narrowed lanes and lanes that have been restriped to add capacity



Narrower lane widths can be used to allow introduction of a two-way centre left turn lane.

#### Complementary Guidelines:

- Protecting Employment Areas and Freight Facilities, specifically Guidelines 2.2.2, 2.2.3, and 2.2.6
- Planning for the Freight Movement Network, specifically Guidelines 2.3.2, 2.3.5, and 2.3.7
- Improved Integration of Transportation and Land Use Planning, specifically Guidelines 2.4.1, 2.4.2, and 2.4.3
- Institutional Sites
- Site Design to Support Freight Mobility in Existing Urbanized Areas
- Site Design to Support Freight Movement in New Mixed-Use Areas
- Access and Intersections, specifically Guidelines 4.1.1, 4.1.2, 4.1.3, 4.1.5, and 4.1.6
- Corridors
- Freight Gateways
- Requirements, By-Laws, Policies, and Practice, specifically Guidelines 4.4.2 and 4.4.4
- Implementation Tools, specifically Guideline 5.2.5

#### Scope:

- Site, District, and Municipal
- District

#### Settlement size:

- All
- 

#### Required resources:

- \$\$
- \$

#### Land type:

- All
-

## Strategies for Geometric Improvements

Scope:	Settlement size:	Required resources:
Site	All	a., c. \$ b. \$\$

### Land type:



b-c. All

### Complementary Guidelines:

- b. 4.1 Access and Intersections, specifically Guideline 4.1.3
- c. 4.1 Access and Intersections, specifically Guidelines 4.1.2 and 4.1.5

- a. Consider the classification of the road and whether or not it is a designated or principal truck route when designing roads for trucks.
- b. Design roads to recognize the changing performance characteristics of large trucks. The following issues should be considered when providing infrastructure for trucks:
  - i. Design turns or curves recognizing that most drivers tend to oversteer at least once while turning;
  - ii. On dry pavement, trucks will roll over before they skid. On wet pavement, trucks will roll over before skidding at speeds below 80 kilometres an hour, but for higher speeds, skidding will occur;
  - iii. Cross-slopes should be kept to a minimum on high-speed highways, especially when trucks are passing and crossing over the centreline crowns; and
  - iv. Reverse curves create truck instability due to high yaw forces developed at the curve tangent points.
- c. Place truck rollover warning systems at locations where these incidents occur fairly often.
- d. Provide infrastructure that allows trucks to exit the road without impacting through traffic.
- e. Provide over-height vehicle detection and warning systems to inform trucks if they are approaching a structure with low vertical (height) clearance (see [Figure 4.18](#)). An alternative routing message should also be provided at these locations to direct trucks around the structure and back to their original route.

**Figure 4.18: Over-dimension warning signs**

An over-height warning sign can be placed on an underpass to warn truck drivers of a height restriction. Underpasses that cannot accommodate all truck sizes should be avoided on major truck corridors.



## Strategies for Traffic Signal Improvements

- a. Limit the impact of traffic congestion on freight movement along a corridor. On low-speed corridors, traffic signal timing can be improved by reducing cycle times as much as possible, incorporating truck speeds into signal timing (see [Guideline 4.2.1](#)), and minimizing signal density. On high-speed corridors, loop detectors and vehicle classifiers can be used to identify trucks approaching an intersection and truck priority logic can be programmed into the signal to reduce the number of stops by trucks.

**Scope:**

 District and  
Municipal

**Settlement  
size:**

All

**Required  
resources:**

\$\$

**Land type:**

**Complementary Guidelines:**

- 2.3 Planning for the Freight Movement Network, specifically Guideline 2.3.6
- 4.1 Access and Intersections, specifically Guidelines 4.1.1 and 4.1.2

## Strategies for Connectivity Improvements

- a. Increase bridge strength capacities. Understanding where heavy trucks are coming from, where they are going, and their travel patterns is usually necessary to properly identify the bridges providing the best connections for heavy trucks.
- b. Increase vertical clearances and/or direct trucks away from low bridges and tunnels well in advance using clear detour directions to roads which have a clearance of 4.65 m.
- c. Identify commercial truck routes for access to warehouses, distribution centres, *intermodal facilities*, manufacturing facilities, quarries, and landfill/resource recovery facilities.

**Scope:**

 a. District,  
Municipal,  
and Region

**Settlement  
size:**

a-b. All

c. -

**Required  
resources:**

a. \$\$\$

c. \$\$

b. Municipal

**Land type:**

**Complementary Guideline:**



- c. 2.2 Protecting Employment Areas and Freight Facilities, specifically Guideline 2.2.5
- a-b. 4.1 Access and Intersections, specifically Guideline 4.1.6

Figure 4.19: Bridge weight rating sign

This sign can be used to indicate the maximum allowable vehicle weight on a bridge.



## Strategies for Travel Time and Reliability Improvements

Scope:	Settlement size:	Required resources:
a. District and Municipal	a.  -	a. \$\$\$
b. Municipal and Region	b.  All	b. \$

**Land type:**

- a. 
- b. All

**Complementary Guideline:**

- a. 4.1 Access and Intersections, specifically Guideline 4.1.6

- a. Utilize incident management systems and lower the amount of non-recurring delays. Three types of information systems are often available: variable message signs (VMS) (see [Figure 4.20](#)), VMS and travel time displays (TTD), and dynamic route guidance systems (DRGS). A useful option is providing travel time displays on arterial streets ahead of the entrances to on-ramps of expressways. These displays can show the travel time from the on-ramp to major exits and destinations or warn of incidents impacting travel time.
- b. Minimize strategies or infrastructure which place lane restrictions on trucks.

*Figure 4.20: Alternative routing information displayed on a variable message sign*



Variable message signs can be an effective tool for communicating real-time information and re-routing information to trucks travelling along major corridors.



# Crossings of Divided Highways and Railways

## 4.2.2 Design facilities that accommodate truck characteristics when crossing a divided highway

Trucks require special consideration when crossing divided roadways due to their length and acceleration capabilities. Gap acceptance is an important issue since it is used to determine intersection sight distance, capacity, waiting length, delay at unsignalized intersections, and the need for traffic signals.

Special treatment may be needed near freight facilities that have driveways or access roads intersecting with a highway or divided expressway. The high speeds of traffic moving along the highway/expressway can make crossing more difficult and risky, especially when traffic volumes are high.

### Strategies for Gap Acceptance for Trucks

- a. Regularly monitor traffic gaps at uncontrolled intersections where trucks must cross a divided roadway. If acceptable gaps are not available, installing intersection control devices should be considered.

Figure 4.21: Truck blocking lanes while making a turn



The truck shown in this photograph attempted to make a left turn onto a major truck route. The driver was unable to complete the entire manoeuvre and was forced to block one direction of traffic while waiting for an appropriate gap to complete the turn.

### Complementary Guidelines:

- 2.2 Protecting Employment Areas and Freight Facilities, specifically Guideline 2.2.6
- 2.3 Planning for the Freight Movement Network, specifically Guidelines 2.3.2, 2.3.5, and 2.3.7
- 2.4 Improved Integration of Transportation and Land Use Planning, specifically Guidelines 2.4.1, 2.4.2, and 2.4.3
- 3.7 Site Design to Support Freight Mobility in Existing Urbanized Areas
- 3.8 Site Design to Support Freight Movement in New Mixed-Use Areas
- 4.1 Access and Intersections, specifically Guideline 4.1.1
- 4.2 Corridors, specifically Guideline 4.2.1
- 5.2 Implementation Tools, specifically Guideline 5.2.5

### Scope:

Site

### Settlement size:

All

### Required resources:

\$

### Land type:



## Strategies for Median Design

<b>Scope:</b>	<b>Settlement size:</b>	<b>Required resources:</b>
Site	All	<b>\$ - \$\$</b>
<b>Land type:</b>		
All		

- a. Design median widths to properly account for trucks. A practical way to accommodate trucks making turns across medians without disrupting through traffic is to use a wide median, which will allow enough space for all vehicle types to wait for a safe gap in traffic before making a turn.
- b. Consider installing median acceleration lanes at locations where there is enough median width available and the following are true: limited gaps are available in the major-road traffic stream; turning traffic must merge with high-speed through traffic; there is a history of rear-end or sideswipe accidents; intersection sight distance is poor; and there are high volumes of trucks entering the divided highway (greater than 75 trucks per day).
- c. Consider the strategies discussed above for intersections controlled by traffic signals but that switch back to two-way flashing operation during off-peak or night-time conditions.

## Strategies for Crossing Railways

<b>Scope:</b>	<b>Settlement size:</b>	<b>Required resources:</b>
Site	All	<b>\$</b>
<b>Land type:</b>		
All		

- a. Ensure that longer trucks, especially those with rigid B-train connections, are not at risk of getting stuck over railway crossings by designing the crossing surface of a railway track to be at the same plane (level) for a distance of one (1) metre outside of the rails to prevent low-clearance vehicles from becoming caught on the tracks.

# Ascending and Descending

## 4.2.3 Accommodate truck characteristics when ascending or descending grades

Trucks are sensitive to ascending and descending grades, which is a result of their weight. Maintaining the speed of heavy vehicles on upgrades is mainly a function of the weight-to-power ratio of trucks, which makes it important to understand the types of trucks that are most often using a roadway with steep grades.

While all trucks are required to meet minimum braking requirements, the main concern related to trucks on descending grades is the possibility for brakes to overheat and lose braking ability. Brake ability will only come back once the brake pads have cooled down enough, which may not happen prior to the truck losing control. Drivers need to select the proper gearing and appropriate speed prior to the descending grade to mitigate some of these concerns.

### Strategies for Climbing Lanes

- a. Continue the practice of providing additional lanes to allow faster traffic to overtake slower traffic. This should be based on standard criteria relating to the degree of incline of a roadway and the length of the inclined portion (see [Figure 4.22](#)).



#### Complementary Guidelines:

- 2.2 Protecting Employment Areas and Freight Facilities, specifically Guideline 2.2.6
- 2.3 Planning for the Freight Movement Network, specifically Guidelines 2.3.2, 2.3.5, and 2.3.7
- 2.4 Improved Integration of Transportation and Land Use Planning, specifically Guidelines 2.4.1, 2.4.2, and 2.4.3
- 3.10 Rural Sites
- 4.1 Access and Intersections, specifically Guideline 4.1.2
- 4.2 Corridors, specifically Guideline 4.2.1
- 5.2 Implementation Tools, specifically Guideline 5.2.5

#### Scope:

Municipal and Region

#### Settlement size:

All

#### Required resources:

\$\$\$

#### Land type:

All

*Figure 4.22: Climbing lane*

A truck is using the climbing lane on this uphill stretch of road. The road sign in the background reads "Slower Traffic Keep Right".

### Strategies for Truck Protection on Downgrades

<b>Scope:</b>	<b>Settlement size:</b>	<b>Required resources:</b>
Municipal and Region	All	\$\$-\$\$\$
<b>Land type:</b>		
All		

- a. Provide an emergency escape ramp in the middle to lower portion of downgrades (see Figure 4.23). Escape ramps should be wide enough to store two runaway vehicles. The U.S. Federal Highway Administration’s Interactive Highway Safety Design Model (IHSDM) provides four speed criteria for providing an escape ramp and five steps to determine the potential locations for escape ramps.

Figure 4.23: Escape ramp

A runaway truck ramp is provided as a safety precaution along this steep grade of roadway.





### Strategies for Warning Systems

<b>Scope:</b>	<b>Settlement size:</b>	<b>Required resources:</b>
District and Municipal	All	\$\$
<b>Land type:</b>		
All		

- a. Install fixed roadside warning signs. Post recommended descent speeds for transport trucks based on their gross weight.
- b. Install dynamic warning (message) signs that target vehicles at risk of losing control on the downgrade. These systems use changing message signs to alert and inform individual trucks of a safe speed for the upcoming grade. Vehicle weight is an important factor in determining loss-of-control risk so the incorporating of weigh-in-motion (WIM) devices with these dynamic systems is recommended.

### Strategies for Geometric Design

<b>Scope:</b>	<b>Settlement size:</b>	<b>Required resources:</b>
a-b., District and d-e. Municipal	All	a-b. \$\$\$ c-e. \$
c. Site, District, and Municipal		
<b>Land type:</b>		
a.  b. All c-e. 		

- a. Consider restriping two-lane undivided roads with wide lanes or wide shoulders to create 2+1 roadways. This will provide a buffer between travel directions and to create flexibility (see Figure 4.24).
- b. Provide downgrade passing lanes, especially where trucks must use lower gears.
- c. Increase stopping sight distance on downgrades where there are horizontal sight obstructions, particularly on long downgrades where truck speeds may exceed that of car speeds.

- d. Increase *super-elevation* on downgrade curves. When longer trucks approach a horizontal curve on a downgrade, the downward force on the front axle is increased and decreased on the rear axle. This load shift can lower the lateral force on the rear axle, and if the truck is travelling too close to the maximum safe speed, when the brakes are applied, the truck risks losing traction, causing the truck to spin. To reduce the possibility of this problem, higher *super-elevation* rates can be used on roads with downgrades greater than 3%, using the following equation: *Super-elevation* increase (%) = (g + e)/6 where g = downhill grade (%) and e = curve *super-elevation* (%). Fractions should be rounded up.
- e. Avoid sharp curves at the end of long downgrades.

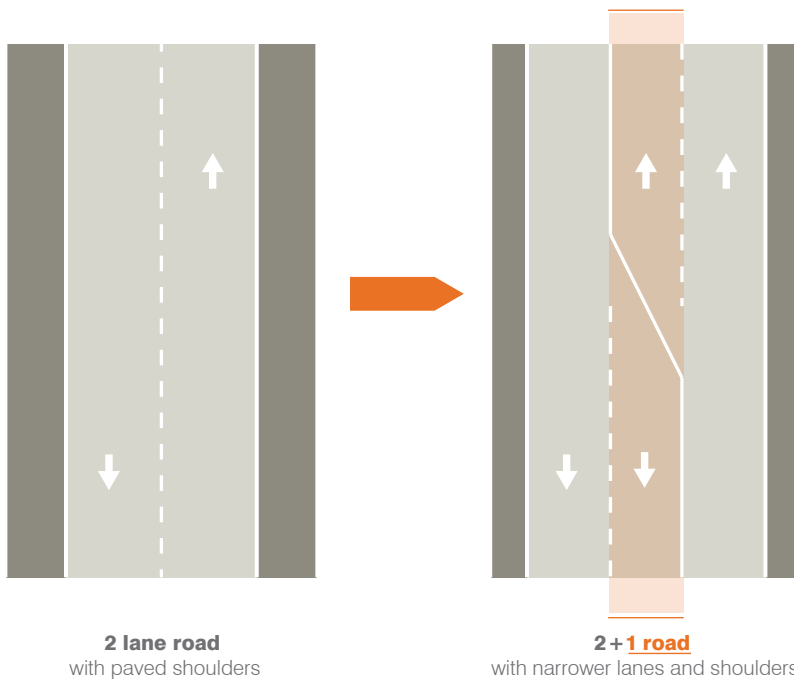

Figure 4.24: 2+1 Roadway

Restriping this two-lane undivided highway as a 2+1 road introduces a passing lane within the existing right-of-way.

### Strategies for Regulations

- a. Ban trucks from passing each other and restrict them to one lane on steep upgrades.

<b>Scope:</b>	<b>Settlement size:</b>	<b>Required resources:</b>
District and Municipal	All	\$
<b>Land type:</b>		
All		

## 4.3 Freight Gateways

### Connecting Intermodal Facilities and Highways

**Complementary Guidelines:**





- 2.2 Protecting Employment Areas and Freight Facilities, specifically Guideline 2.2.3
- 2.3 Planning for the Freight Movement Network, specifically Guidelines 2.3.2 and 2.3.6
- 2.4 Improved Integration of Transportation and Land Use Planning, specifically Guidelines 2.4.1, 2.4.2, and 2.4.3
- 3.2 Industrial Sites
  - 4.1 Access and Intersections, specifically Guideline 4.1.6
  - 4.2 Corridors, specifically Guideline 4.2.1
  - 4.3 Freight Gateways, specifically Guidelines 4.3.2, 4.3.3, and 4.3.4
  - 4.4 Requirements, By-Laws, Policies, and Practice, specifically Guidelines 4.4.2, 4.4.3, and 4.4.4

**4.3.1 Municipalities should plan for truck movements on municipal roads from *intermodal* terminals to connect to the provincial highway system.**

*Intermodal facilities* serve heavy truck volumes moving between terminals and the provincial highway system, and commonly run through older, industrial and mixed land use areas with physical constraints.

*Intermodal facilities* create unique challenges for truck traffic operations. Truck traffic patterns are influenced by the arrival and departure of container trains, and the availability for containers for pick up, as containers can remain at the *intermodal* facility for about three days before storage charges start to apply. The *transportation system* should be designed to accommodate this peaking.

**Strategies for Access, Capacity, and Routing**

<b>Scope:</b>	<b>Settlement size:</b>	<b>Required resources:</b>
District and Municipal	a-e. All f-g.  - 	a-d., f-g. \$\$ e. \$\$\$
<b>Land type:</b>		
a, c-g.  b. 		

- a. Provide options and multiple routes to access key freight facilities.
- b. Consider appointment systems to improve pickup and delivery scheduling, in an effort to reduce truck wait times and manage traffic.
- c. Ensure that there is enough capacity and space on roads leading to terminals, especially during peak periods of truck traffic.
- d. Work with railways to ensure that there is enough capacity on internal roads within the *intermodal facilities* to accommodate the expected truck traffic, and to prevent trucks from waiting on external roads outside of the facility.
- e. Plan and build infrastructure to accommodate increased traffic due to larger trucks and double-stack container trains.
- f. Enforce traffic operational policies on connectors to support the hours of operation of *intermodal facilities*.
- g. Provide enough staging areas around *intermodal facilities* and along their associated corridors.

*Figure 4.25: Sign showing the direction of the main highway*  
A directional sign is used to guide vehicles to the highway.



## Strategies for Guidance

- a. Provide signage to direct trucks to terminal from highway and vice-versa (see [Figure 4.25](#)).

<b>Scope:</b>	<b>Settlement size:</b>	<b>Required resources:</b>
District and Municipal	 - 	\$
<b>Land type:</b>		

## Strategies for Truck-Rail Interaction

- a. Initiate dialogue between the private sector and other levels of government to determine the appropriate treatment of locations where there is truck-rail interaction.
- b. Work with the private sector and other levels of government to construct grade separations at rail crossings on routes connecting *intermodal facilities* to highways and other key destinations.

<b>Scope:</b>	<b>Settlement size:</b>	<b>Required resources:</b>
District and Municipal	 - 	\$ - \$\$\$
<b>Land type:</b>		

# Cross-Docking and Transload Facilities

## 4.3.2 Support efficient access to truck terminals and transload facilities: Provide infrastructure and traffic control to support truck access to these sites, and create direct routes between these facilities, *intermodal facilities*, and distribution centres

Cross-dock and transload facilities are being used by shippers, ports, and carriers in response to just-in-time delivery demands and the result of the need to consolidated loads because of smaller shipments. Freight is unloaded from inbound trucks, sorted, consolidated, and reloaded into outbound trucks.

Cross-dock and transload facilities can provide freight consolidation or deconsolidation services. In some cases, a single container of freight can be divided into multiple smaller truckloads to serve multiple destinations. In other cases, freight from multiple containers can be consolidated into a single truckload. Freight often is stored between the inbound and outbound movement and on-site storage areas may be required.





### Complementary Guidelines:

- 2.2 Protecting Employment Areas and Freight Facilities, specifically Guidelines 2.2.2, 2.2.4, and 2.2.5
- 2.3 Planning for the Freight Movement Network, specifically Guidelines 2.3.2 and 2.3.6
- 2.4 Improved Integration of Transportation and Land Use Planning, specifically Guidelines 2.4.1 and 2.4.3
- 3.2 Industrial Sites
  - 4.1 Access and Intersections, specifically Guideline 4.1.6
  - 4.2 Corridors, specifically Guideline 4.2.1
  - 4.3 Freight Gateways, specifically Guidelines 4.3.1, 4.3.3, and 4.3.4
  - 4.4 Requirements, By-Laws, Policies, and Practice, specifically Guidelines 4.4.2, 4.4.3, and 4.4.4

*Figure 4.26: Cross-dock facility*

At this cross-docking facility, freight is transferred from a container, to a warehouse, and then to trucks bound for multiple destinations.

<b>Scope:</b>	<b>Settlement size:</b>	<b>Required resources:</b>
a-b. District, Municipal, and Region	a-b. All	\$
c. Municipal and Region	c. 	
<b>Land type:</b>		
a-b. 		
c. All		

**Complementary Guidelines:**

- 2.2 Protecting Employment Areas and Freight Facilities, specifically Guidelines 2.2.2 and 2.2.5
- 2.3 Planning for the Freight Movement Network, specifically Guideline 2.3.6
- 2.4 Improved Integration of Transportation and Land Use Planning, specifically Guidelines 2.4.1 and 2.4.3
- 4.1 Access and Intersections, specifically Guidelines 4.1.3 and 4.1.6
- 4.2 Corridors, specifically Guideline 4.2.1
- 4.3 Freight Gateways, specifically Guidelines 4.3.1, 4.3.2, and 4.3.4
- 4.4 Requirements, By-Laws, Policies, and Practice

**Figure 4.27: Intermodal container train**

*Intermodal* containers are only one component of freight movement through *marine facilities*. Often, containers are transferred between ships and double-stacked *intermodal* trains, such as the one pictured here, for long-distance hauls. Alternatively, trucks may be used to haul containers for shorter distances. These movements are referred to as *drayage*.

**Strategies for Cross-Docking and Transload Facilities**

- a. Initiate dialogue between municipality and rail, cross-dock and *transload facility* operators in order to plan for safe and efficient access to these facilities.
- b. Encourage distribution centres to locate in close proximity to each other in order to encourage less vehicle kilometres traveled and to dedicate road and network improvements to specific routes.
- c. Plan for integrated *logistics* centres (ILCs) that co-locate *intermodal facilities* with large shippers and eliminate the movement of trucks between these facilities.

**Marine Facilities****4.3.3 Support efficient operations within and around *marine facilities* to allow freight flows to/from and through the municipality, while promoting sustainability and livability in neighbouring communities**

*Marine facilities* are key nodes within the global supply chain that support the international trade of freight by ships, trains, and trucks. When developing strategies to improve operations in and around a marine facility, a municipality should seek a balanced approach between private and public-sector interests, between operational issues within and around the facility, and promoting economic growth.

A municipality also should conduct a *freight audit* as described in Section 2.1 to confirm the needs and benefits of building or improving road or rail connections to port facilities. There may be need to protect for exceptional load movements requiring special clearances for vehicles.

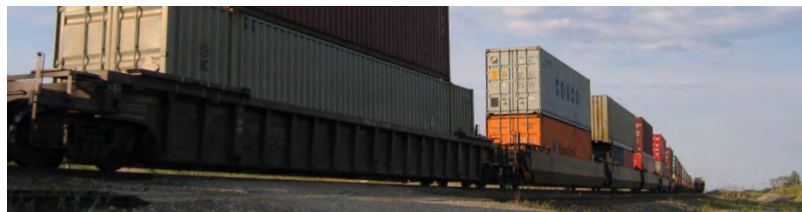
**Strategies for Engaging Stakeholders**

- a. Develop and implement a communication process between the local municipality and the port authority that allows the sharing of information about:
  - i. land use development plans and proposals within and around the marine facility; and





<b>Scope:</b>	<b>Settlement size:</b>	<b>Required resources:</b>
Municipal	 - 	\$
<b>Land type:</b>		
All		



- ii. past, current, and expected port freight volume and commodity type to identify trends, improve confidence in projections, and help in planning for future infrastructure and operational improvements.

### Strategies for Truck Operations around the Facility

- a. Based on the results of the *freight audit*, undertake site specific improvements to address geometric design issues (i.e., poor turning radii, number of turning lanes, ramp configurations, insufficient clearance or width for oversize loads) on roads most often used by trucks accessing the marine facility.
- b. Based on the results of the *freight audit*, undertake site specific improvements to traffic control problems (i.e., adjust signal timing, signage) on roads most often used by trucks accessing the marine facility.
- c. Ensure that the marine facility can be properly accessed by trucks. This involves providing connections from the truck route network and considering development of truck only corridors. Before building or improving road and rail connections, municipalities should first confirm need and benefit of the investment to the facility.
- d. Implement intelligent transport systems, which are directed at reducing and managing traffic congestion and waiting in the vicinity of the port.
- e. Encourage the modernization of the *drayage* fleet to lower air pollution impacts.



Scope:	Settlement size:	Required resources:
a-b. Site		
c-e. District and Municipal	 - 	<b>\$\$</b>
<b>Land type:</b>		
a-b. 	d. 	
c-e. All		

#### Complementary Guideline:

- a. 4.1 Access and Intersections, specifically Guideline 4.1.3

### Strategies for Rail Operations around the Facility

- a. Work with rail companies to explore options to invest in grade-separated rail infrastructure.
- b. Work with rail companies to develop a rail spur or connection to allow rail service to/from a marine facility.
- c. Work with rail companies to regain potential for relocating a rail yard to an on-dock location to minimize the need for truck *drayage*.
- d. Work with *marine facilities* to change hours of operation around *marine facilities* to manage traffic and congestion at at-grade rail crossings in areas where there are ongoing conflicts or problems.
- e. Encourage or participate in investments in intelligent transport systems that are directed at improving rail operations in the area around the port.

Scope:	Settlement size:	Required resources:
a. Site, District, and Municipal	 - 	<b>\$\$\$</b>
b. Site and District		
c. District and Municipal		
d. Site		

**Land type:**  
All

#### Complementary Guideline:

- d. 4.4 Requirements, By-Laws, Policies, and Practice, specifically Guideline 4.4.1

## Air Facilities

### Complementary Guidelines:

- 2.2 Protecting Employment Areas and Freight Facilities, specifically Guidelines 2.2.2 and 2.2.5
- 2.4 Improved Integration of Transportation and Land Use Planning, specifically Guidelines 2.4.1 and 2.4.3
- 4.1 Access and Intersections, specifically Guidelines 4.1.3 and 4.1.6
- 4.2 Corridors, specifically Guideline 4.2.1
- 4.3 Freight Gateways, specifically Guidelines 4.3.1, 4.3.2, and 4.3.4
- 4.4 Requirements, By-Laws, Policies, and Practice

Figure 4.28: Air cargo sign

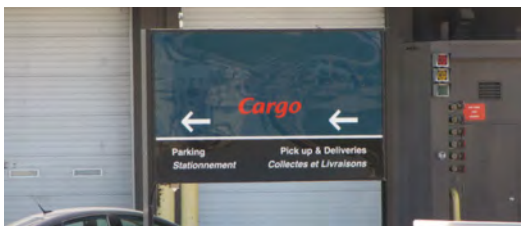

This sign, located inside an air facility, provides clear guidance to truck drivers hauling air cargo about where to find parking and pick-up/drop-off locations.

### 4.3.4 Support time-sensitive operation of air cargo facilities by improving truck operations in and around the air facility

Air cargo is a fast-growing part of the freight transportation industry. A typical air cargo trip involves the movement of high-value and/or time-sensitive cargo by an air carrier, plus the movement of that cargo by truck to/from the air cargo facility. An air carrier may be a combination carrier (passenger and freight) or an all-cargo carrier (integrated carriers or line haul carriers). Freight forwarders, companies or individuals that offer logistical and transportation services, may work with air carriers to transport freight between destinations. In certain regions, delivery of cargo to northern or remote destinations may be an important component of air cargo movements.

Strategies directed at improving operations in and around air cargo facilities involve multiple stakeholders from the private and public sectors. Stakeholders typically include the airport authority, air carriers, trucking companies, mail service providers, logistics service providers, and municipal governments.

Truck traffic operational issues are an important component of an air cargo shipment. Achieving travel time reliability in the truck route network serving an air cargo facility is an important objective.

### Strategies for Truck Operations around the Facility

Scope:	Settlement size:	Required resources:
a., c. Site		a-b. \$\$
b. Site and District		c-e. \$
d-e. Municipal		
<b>Land type:</b>		
a.		
b-e. All		

### Complementary Guideline:

- a. 4.1 Access and Intersections, specifically Guideline 4.1.3

- a. Based on the *freight audit*, undertake site specific improvements to geometric design deficiencies, traffic control devices and directional signage to improve access to and from the air facility.
- b. Collaborate with the airport authority to optimize signage and connectivity of the network.
- c. Develop truck-only routes and use appropriate signage to separate freight and passenger traffic on streets that provide direct access to air cargo centres and in passenger pickup/drop-off areas. Specific ways to achieve this strategy include developing truck only accesses and using proper signage to separate traffic as it approaches the air facility.
- d. Using the results of the *freight audit*, ensure that the municipal truck route network provides clear and adequate access to air cargo facilities.
- e. The airport operator, with support from the municipality, should provide adequate space for truck parking, waiting, and storage in the vicinity of the air facility.

## 4.4 Requirements, By-Laws, Policies, and Practice

### Harmonization of Requirements and By-laws

#### 4.4.1 Harmonize truck-related requirements and by-laws of the municipality with those in neighbouring or upper-tier municipalities to support seamless movement of freight across jurisdictional boundaries

Regulations governing trucking operations in Ontario are diverse, governing aspects such as truck size and weight, vehicle-related safety requirements, driver licensing and credentials, and environmental control. These regulations are directed at promoting vehicle productivity while ensuring safety, preserving infrastructure, and limiting negative environmental effects. The Highway Traffic Act and associated regulations pertaining to vehicle weights and dimensions are harmonized across Ontario (Reg. 413-05) and all municipalities follow these.

Harmonizing municipal requirements and by-laws related to designated truck routes, time of day for truck usage and seasonal load restrictions with those in neighbouring and upper-tier municipalities can support the seamless movement of freight across jurisdictional boundaries. Identifying opportunities for *harmonization* should include regular review of relevant requirements and by-laws and ongoing collaborative stakeholder consultation.

#### Strategies for Identifying Harmonization Opportunities

- Through the *freight audit*, identify municipal truck-related requirements and by-laws that may limit truck productivity because of a lack of cross-jurisdictional *harmonization*.

Examples of these types of requirements and by-laws are: ensuring that designated truck routes and oversize/overweight load routes continue once they cross into other municipalities, the timing of seasonal road restrictions, and noise-related considerations such as the time of day usage for certain routes.

- As part of the *freight audit*, consult industry stakeholders to help identify operational issues that result from inconsistencies between requirements or by-laws in different jurisdictions.

#### Complementary Guidelines:

- Protecting Employment Areas and Freight Facilities, specifically Guidelines 2.2.2 and 2.2.3
- Planning for the Freight Movement Network, specifically Guidelines 2.3.2 and 2.3.3
- Improved Integration of Transportation and Land Use Planning, specifically Guidelines 2.4.1 and 2.4.3
- Access and Intersections, specifically Guideline 4.1.6
- Freight Gateways, specifically Guideline 4.3.3
- Requirements, By-Laws, Policies, and Practice, specifically Guideline 4.4.3
- Implementation Tools, specifically Guideline 5.2.5

Figure 4.29: Municipal noise restriction



This sign informing truck drivers about a noise restriction is applicable for the local municipality.

Scope:	Settlement size:	Required resources:
Municipal	All	\$
<b>Land type:</b>		
All		

- c. Evaluate inconsistencies in by-laws and consider or explore opportunities for *harmonization*.
- d. Document and prioritize opportunities for harmonizing truck-related requirements and by-laws.

### Implementation Strategies

<b>Scope:</b>	<b>Settlement size:</b>	<b>Required resources:</b>
Municipal and Region	All	\$
<b>Land type:</b>	a. 	
All		

- a. Analyze the technical, economic, social, and environmental implications of implementing harmonized requirements and by-laws.
- b. Monitor trucking activity to promote compliance with new requirements and by-laws.

### Communication Strategies

<b>Scope:</b>	<b>Settlement size:</b>	<b>Required resources:</b>
Municipal and Region	All	\$
<b>Land type:</b>		
All		

#### Complementary Guideline:

- a. 4.1 Access and Intersections, specifically Guideline 4.1.6

- a. Provide proper signage to help inform truck drivers about local requirements and by-laws that may be different from neighbouring or upper-tier municipalities.  
The signs should provide regulatory, warning, and directional messages according to the principles of the positive guidance approach.
- b. Publicize information about unique municipal requirements and by-laws using the internet. Ensure that there is enough timely information provided to truck drivers to aid them when selecting alternative routes.

## Effective Truck Route Operations

### 4.4.2 Manage and communicate information about the daily operations of truck route networks

#### Complementary Guidelines:

- 2.2 Protecting Employment Areas and Freight Facilities, specifically Guidelines 2.2.2 and 2.2.3
- 2.3 Planning for the Freight Movement Network, specifically Guideline 2.3.2
- 2.4 Improved Integration of Transportation and Land Use Planning, specifically Guideline 2.4.1
- 4.1 Access and Intersections, specifically Guideline 4.1.6
- 4.2 Corridors, specifically Guideline 4.2.1
- 4.3 Freight Gateways
- 4.4 Requirements, By-Laws, Policies, and Practice, specifically Guideline 4.4.3
- 5.2 Implementation Tools, specifically Guideline 5.2.5

Truck route networks are established and managed to allow for the safe and efficient movement of freight while minimizing the impacts on *sensitive land uses*. Routes are established to address freight demands and are designed to accommodate the operational characteristics of trucks.

The ability for a truck route network to be effective depends on clear and timely communication with truck drivers who may be unfamiliar with local conditions. Proper communication helps drivers plan safe and efficient routes, deliver loads in a timely manner, avoid routing errors, and minimizes enforcement requirements.

Truck maps should include information such as full loads, restricted loads, time of day restrictions, and routes designated for specific users.

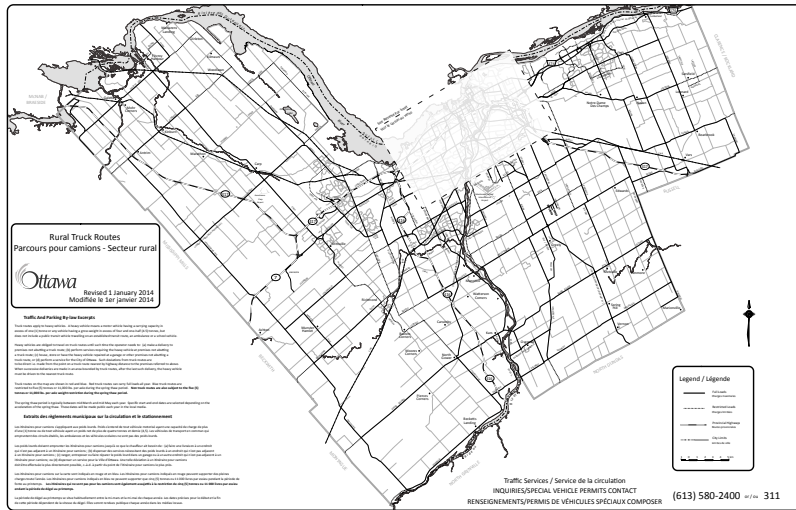

Figure 4.30: Example truck route network map/ schematic

A publicly available truck route network map provides truck drivers that may be unfamiliar with the area the information necessary for safe and efficient navigation, including which links are designated for trucks and and/or those links on which trucks are prohibited.

### Strategies for Establishing Truck Route Networks

- Ensure connectivity within a single jurisdiction’s truck route network and between truck route networks in neighbouring jurisdictions.
- Ensure that a network of truck routes are available for use year-round on a 24 hour/day and 7 day/week basis.
- Establish designated routes and/or restrictions for trucks carrying oversize/overweight loads (see Figure 4.31).

<b>Scope:</b>	<b>Settlement size:</b>	<b>Required resources:</b>
a., c. Municipal and Region	All	a., c. \$
b. Municipal		c. \$\$\$
<b>Land type:</b>		
All		



Figure 4.31: Overheight when flashing

This system of signs and sensors warns truck drivers if their truck or load exceeds the maximum height allowed for a specific route. The warning flashers are activated if the truck or load breaks a detector beam produced by devices installed on an overhead gantry. Alternative routing information is provided.

## Management Strategies

<b>Scope:</b>	<b>Settlement size:</b>	<b>Required resources:</b>
Municipal	All	\$ - \$\$
<b>Land type:</b>	b. 	
All		

### Complementary Guidelines:

- b. 2.4 Improved Integration of Transportation and Land Use Planning, specifically Guideline 2.4.1

- Monitor the performance of the truck route network over time. Performance measures (i.e., truck traffic volume, accidents involving trucks, travel time, speed) should be monitored and compared to appropriate targets. If targets are not met, consider adjustments.
- In situations where no viable truck route is available year-round, seasonal load restrictions may be necessary to protect infrastructure during periods when it is less capable of handling loads (i.e., during thaw periods or while under construction).

*Figure 4.32: Spring load restriction*

This sign indicates that spring load restrictions are in effect for this road.



## Communication Strategies

<b>Scope:</b>	<b>Settlement size:</b>	<b>Required resources:</b>
Municipal	All	\$
<b>Land type:</b>		
All		

- Ensure that proper signage is provided to help guide truck drivers who may be unfamiliar with local roads and networks (see [Figure 4.33](#) and [Figure 4.34](#)).
- Publicize truck route networks (see [Figure 4.30](#)), physical restrictions, and special restrictions related to oversize/overweight loads (see [Figure 4.32](#) and [Figure 4.35](#)), or temporary conditions (i.e., construction, road conditions) using the internet. Interactive, real-time, web-based maps, accompanied by text-based reports, are useful communication tools.
- Distribute truck route network informational brochures and maps at public rest areas and private truck stops and through municipal websites.
- Work with the trucking industry to establish and promote frequent updates on road network conditions being provided to truck drivers via on-board devices.

Figure 4.33: Truck route sign



This sign indicates that trucks are permitted along the through street.

Figure 4.34: Not a truck route



This sign, located at a major urban intersection, informs truck drivers of a truck operational restriction, likely due to the narrowing of the cross-section ahead.

Figure 4.35: Maximum width on bridge



This sign informs truck drivers of a temporary restriction on vehicle width (3.7 metres) on an upcoming bridge. Changes to the normal operating environment due to construction or other temporary conditions should be clearly communicated to drivers.

## Demand Management Strategies

### 4.4.3 Explore opportunities for managing freight transport demand in urban areas by introducing or enhancing incentives to encourage off-peak freight pickups and deliveries



Shifting urban freight pickups and deliveries away from periods of peak traffic volumes helps to lower traffic congestion and travel times, and may also curb mobile-source emissions. Successful implementation of off-peak pickup and delivery schedules requires an understanding of, and compliance with, municipal requirements and by-laws addressing delivery times as well as industry (shipper, receiver and freight delivery company) engagement and holistic policy development.

#### Complementary Guidelines:



- 2.2 Protecting Employment Areas and Freight Facilities, specifically Guidelines 2.2.2 and 2.2.3
- 2.3 Planning for the Freight Movement Network, specifically Guideline 2.3.2
- 2.4 Improved Integration of Transportation and Land Use Planning, specifically Guideline 2.4.1
- 3.2 Industrial Sites
- 3.4 Retail Sites
- 4.3 Freight Gateways
- 4.4 Requirements, By-Laws, Policies, and Practice, specifically Guideline 4.4.2
- 5.2 Implementation Tools, specifically Guidelines 5.2.5 and 5.2.7

Figure 4.36: Carrier home-base and a chain of receivers

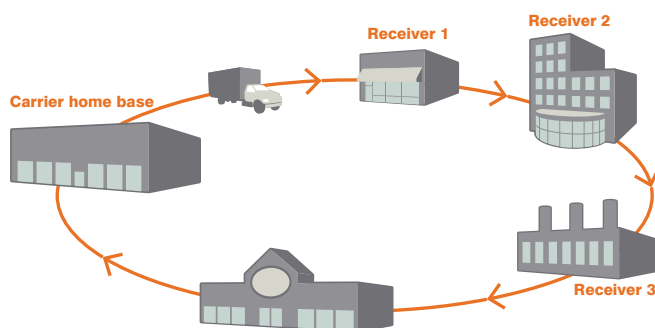
Effectively shifting urban deliveries to off-peak hours may require all receivers within a distribution chain to adjust the hours during which they accept deliveries.



## Policy and Planning Strategies

<b>Scope:</b>	<b>Settlement size:</b>	<b>Required resources:</b>
a. Municipal	a. 	a. \$ - \$\$
b. Site, District, and Municipal	b.  - 	b. \$
<b>Land type:</b>		
All		

- a. In high-density areas, with high levels of congestion on local roads, municipalities should work with local shippers and receivers to explore options for off-peak delivery.
- b. Explore opportunities to promote unassisted deliveries to allow more receivers to participate in an off-peak program.

## Multimodal System

### Complementary Guidelines:

- 2.2 Protecting Employment Areas and Freight Facilities, specifically Guidelines 2.2.2 and 2.2.3
- 2.3 Planning for the Freight Movement Network, specifically Guideline 2.3.2
- 2.4 Improved Integration of Transportation and Land Use Planning, specifically Guideline 2.4.1
- 4.2 Corridors, specifically Guideline 4.2.1
- 4.3 Freight Gateways
- 4.4 Requirements, By-Laws, Policies, and Practice, specifically Guidelines 4.4.1 and 4.4.2
- 5.2 Implementation Tools, specifically Guideline 5.2.5

### 4.4.4 Encourage *multimodal integration* and opportunities within the freight transport system to promote efficient and competitive service delivery

An efficient operating freight *transportation system* is enhanced by *multimodal integration*. Freight transportation mode selection is decided by the shipper and is based on cost and time sensitivity. Factors associated with the mode choice include the size of shipment, commodity type, costs, time sensitivity, and trip distance.

Advances in *logistics*, information technology, and increased flexibility in carriers' business models have also promoted multimodal systems.

Figure 4.37: Map showing a Hamilton to Duluth trip with four modal options

Freight originating in Hamilton, Ontario, and destined for Duluth, Minnesota could occur on any of the four modes: highway, rail, marine, or air. The type of transport choice is affected by many factors, including distance, commodity type, size and value of shipment, and the unique operating characteristics of each mode. Note: Map is conceptual and does not represent actual routes.

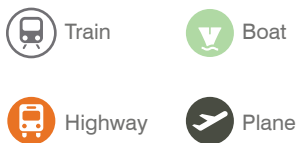



### Data and Information Strategies

- a. Collaborate with neighbouring or upper-tier municipalities on projects directed at improving operations of multimodal freight flows across jurisdictional boundaries.
- b. Based on the *freight audit*, develop criteria to direct investments in multimodal freight transportation projects.
- c. Establish a multimodal freight transportation coordinator or advisory group at regional or upper-tier municipal level.



<b>Scope:</b>	<b>Settlement size:</b>	<b>Required resources:</b>
a. Municipal and Region	 - 	\$
b. Municipal		
<b>Land type:</b>		
All		

Figure 4.38: Rail intermodal terminals

Rail *intermodal* terminals are key nodes within a multimodal system that facilitate the movement of containers between trains and trucks.



### Strategies for Freight-related Requirements, By-laws, and Policies

- a. Consider developing policies that encourage private sector involvement (i.e., through public-private partnerships) in infrastructure projects that promote multimodal freight *transportation systems* and that will mutually benefit all freight stakeholders.

<b>Scope:</b>	<b>Settlement size:</b>	<b>Required resources:</b>
Municipal and Region	All	\$
<b>Land type:</b>		
All		

### Strategies for Multimodal Freight Transportation Infrastructure and Technologies

- a. Prioritize infrastructure projects that address operational bottlenecks or blocks within the multimodal freight *transportation system*.
- b. Ensure a proper level of infrastructure investment at the municipal level.
- c. Support infrastructure projects that help in the efficient operation of multimodal freight facilities.
- d. Invest in intelligent *transportation systems* (i.e., remote tracking, and information systems) that promote multimodal freight system efficiency.

<b>Scope:</b>	<b>Settlement size:</b>	<b>Required resources:</b>
Municipal	a., c-d.  -  b. All	\$ - \$\$\$
<b>Land type:</b>		
All 		



# 5.0 IMPLEMENTATION STRATEGIES

This chapter provides an overview of tools and actions that can be used to implement the guidelines and strategies discussed in the preceding chapters.





## 5.1 Recommended Actions

### 5.1.1 Municipal Leadership

Municipal leadership is needed in order to successfully implement the purpose and objectives of the *Freight-Supportive* Guidelines. Municipalities should consider the following recommendations to aid in establishing an efficient and effective freight movement strategy:

- Recognize the importance and value of freight movement to society and an area's economic advantage within overall long term planning initiatives;
- Define a vision and direction for achieving a sustainable, strong, and adaptive transportation system. Consult applicable provincial plans and policies (e.g., PPS, Growth Plan) when defining the vision, direction and policies. The vision can be supported by quantifiable (measurable) objectives and performance metrics (statistics) and can help direct various transportation improvements projects towards a common goal;
- Develop a fundamental understanding of the freight movement system through a *freight audit*;
- Evaluate transportation system performance to identify, rank, and prioritize areas requiring improvement to help achieve the overall vision. Evaluating systems will provide structure, transparency, and efficiency in making investment decisions, and helps to defend and justify resources dedicated to making these improvements;
- Generate and share data on freight movement activities obtained through the *freight audit* at an appropriate geographic level (i.e., regionally or municipally), including best practices to form a resource for transportation and planning agency staff to address freight movement issues;
- Review or produce site design guidelines to provide direction on designing for freight;
- Review or produce municipal by-laws and regulations that can help manage freight needs within a community. For example, municipalities can designate on-street truck loading and unloading areas. Enforcement of these areas as temporary loading and unloading zones for trucks will aid the efficient movement of freight;
- Coordinate freight movement networks between jurisdictions and municipalities. Establishing coordinated truck route networks is critical for guiding freight along the most efficient route between origins, destinations and intermediate stops;
- Encourage communication, collaboration and partnerships with neighbouring municipalities, as well as between the public and private sector, by:
  - Designing, implementing and maintaining communication forums with the private and public sector partners;
  - Establishing an industry–government advisory group consisting of a range of stakeholders, to demonstrate best practices for municipal implementation and to provide recommendations on congestion and safety, conditions to support economic development, and *harmonization*; and
  - Developing strong connections and relationships with industry leaders.

- Encourage public participation, through collaboration forums and networks, regarding transportation planning and investment. This will increase public awareness on transportation issues to ensure a balance is reached between freight movement needs and livability.

## 5.1.2 Powers under the *Planning Act*

The *Planning Act* sets out the rules for land use planning in Ontario. It provides a variety of tools that municipalities can use to help in planning for the future. The tools and regulations found under the *Planning Act* play a significant role in the successful implementation of the *Freight-Supportive Guidelines*. The key *Planning Act* tools that can be used to facilitate *freight-supportive* communities and economic development are described below.

### 5.1.2.1 Official Plan

An official plan is a statutory planning document, which is required under the *Planning Act* in most municipalities in Ontario. Official plans are high-level policy documents that set out the municipal planning policy vision, guide how land is to be used, and establish where and how growth and development will occur in the future. Official plans are a critical tool for creating *freight-supportive* communities by establishing *freight-supportive* policies.

### Strategies

Official plans provide the framework for the integration of land use and transportation planning, and as such, when drafting or updating the official plan, municipalities should consider, incorporate and emphasize the following strategic elements:

- Reinforce the importance of freight to the municipality and the province from a social and economic perspective;
- Consider the requirement for and use of a freight study (or audit) to inform the drafting and development of official plan policies and designations;
- Identify official plan policies to establish a freight analysis as a requirement for complete applications for certain types of development applications;
- Designate a strategic freight movement network that will help establish an efficient street network for trucks, while balancing noise, safety and accessibility considerations;
- Consider and encourage initiatives that will facilitate effective freight movement, such as freight consolidation centres and alternative delivery strategies;
- Support the needs of the community through increased density and intensification in *settlement areas* that is balanced with requirements for efficient, *freight-supportive* design;
- Develop a multimodal strategy reflecting transportation planning alternatives, to assist in providing additional road capacity for freight movement by shifting people to transit or utilizing *transportation demand management* techniques;

- Assess the need and justification for implementing truck-supportive roads and facilities dedicated as truck routes, and truck priority lanes;
- Encourage the seamless transition of freight corridors across municipal boundaries through coordination with neighbouring jurisdictions;
- Enhance the movement of freight by alternative modes either through land use or infrastructure provisions;
- Coordinate municipal truck restrictions to minimize restrictions on arterial roads based on identified priority corridors;
- Identify *freight-supportive* built form and urban design policies to ensure the creation of a *freight-supportive* urban environment that provides appropriate landscape and buffer materials, guidelines on height, access and signage, while also balancing the needs of *pedestrians* and *cyclists*;
- Include policies enabling site plan control in areas that are affected by freight movement, to allow the approval authority to properly evaluate the development proposals;
- Protect *planned corridors*, including the planned expansion of provincial highway networks and protect for future interchanges and municipal road crossings; and
- Encourage coordination of by-laws and regulations that impact freight movement, both within municipal jurisdictions as well as among adjacent regions and municipalities, to establish acceptable processes that respect local authority and promote economic efficiency and growth in general.

Secondary Plans and Block Plans may also be useful tools in implementing freight-supportive measures.

### 5.1.2.2 Transportation Master Plans

As a supporting document to an official plan, a transportation master plan is a framework that responds to an area's future transportation needs and is intended to inform the development of the official plan and infrastructure investments. The plan anticipates and describes the way the various modes of transportation move within a specific jurisdiction. Transportation master plans need to consider the global nature of freight transportation including the use of multiple transportation modes to connect producers and consumers of goods. The increasing use of transport containers is facilitating seamless transport between modes and providing the cost and time savings necessary for international competition. Air, marine, and rail facility operations must be considered together with road design and truck operations. Municipalities should consider the following when developing Transportation Master Plans:

- Define corridors between air, marine and *rail facilities*, and alternative routings to address unexpected delays and incidents, provide real-time communications systems for trucks, respond to changes in demand, and monitor the performance of the *transportation system*;
- Undertake a *freight audit* to inform the transportation master plan;

- Identify an appropriate freight movement network that meets the needs of moving freight. Important freight corridors and activity centres should be assessed and prioritized for preservation and improvement;
- Integrate land use and transportation decisions;
- Identify strategies to improve the efficiencies of the freight industry;
- Incorporate freight operating characteristics into road design and supporting infrastructure;
- Determine the appropriate use of signage and *Intelligent Transportation Systems (ITS)* needs for freight to provide for the safe and efficient movement of freight within and between communities; and
- Encourage collaboration with other agencies and government levels.

### 5.1.2.3 Zoning By-laws

Zoning by-laws are legal regulations which provincial legislation allows municipalities in Ontario to adopt. Planning policy documents such as official plans and transportation master plans should consider *freight-supportive* policies to ensure that freight is planned for and properly accommodated. Zoning by-laws and development approvals should enforce these policies in order to effectively implement the intent of these Guidelines. These by-laws, which must conform to the municipality's official plan, specify development parameters, including built form, land use and density, which impact the development of *freight-supportive* communities.

#### Strategies

Zoning by-laws should have standards and provisions that:

- Establish complementary permitted uses and zoning along identified freight corridors that complement the freight industry and minimize conflict;
- Require the appropriate built form standards to allow freight activity on a site;
- Require appropriate standards for loading and unloading, access and internal circulation; and
- Implement setback and landscape standards that result in high-quality urban design.

### 5.1.3 Powers under the *Municipal Act, 2001*

The *Municipal Act, 2001* provides local governments with the powers and flexibility to determine the appropriate mechanisms for delivering municipal services to their communities. The *Municipal Act, 2001* provides a range of tools for upper, lower and single-tier municipalities that can be used to support freight. Examples of tools under the Act include by-laws on freight-related matters such as:

- To prohibit and regulate noise, vibration, odour, dust and outdoor illumination, including indoor lighting that can be seen outdoors (Section 129);



- Parking by-law legislation (Section 428), which provides the local municipality with the authority to fine vehicles that have been left parked, stopped or standing in areas where the by-law is applicable. This is helpful in more urbanized areas to control where freight transport deliveries occur, in effect preventing other vehicles from illegally stopping or parking where freight deliveries occur;
- Providing grants to support economic development (Section 107) for purposes that are in the interest of the municipality, such as new or expanded *employment areas* to generate jobs. In addition, Section 204 outlines that a local municipality may designate an area as a business improvement area to support economic development and employment uses; and
- Providing a system for business licensing (Section 151), with the powers to prohibit operating a business without a license, as well as the power to impose special conditions on a business to obtain, hold or renew a license. The requirement for businesses to obtain licenses enables municipalities to ensure that freight operations are appropriately located and have access to necessary freight corridors.

Other useful tools found under the Act that do not specifically speak to freight-related matters, however that can support and/or impact freight include:

- Legislation on imposing operation licensing and road closures, whereby municipalities also have the authority to impose licensing (Section 151), hours of operation regulations (Section 148) and road closures (Section 34), all of which impact freight operations; and
- The site alteration legislation, under Section 142, which states that municipalities may develop by-laws that can regulate development projects which can affect freight movement and the provisioning of infrastructure.

#### 5.1.4 Powers under the *City of Toronto Act, 2006*

The *City of Toronto Act, 2006* provides the city broad powers to pass by-laws on matters related to the City's economic, social and environmental well-being, subject to certain limitations. The Act enables Council to determine appropriate mechanisms for delivering municipal services, appropriate levels of municipal spending and the use of fiscal tools to support initiatives, which in turn affect freight movement and the development of *freight-supportive* infrastructure.

## 5.2 Implementation Tools

### 5.2.1 Community Improvement Plan

Community improvement plans are statutory planning documents which provincial legislation permits single and lower-tier municipalities to develop and adopt for a defined area in the municipality through appropriate official plan policies and designating by-laws. Upper tier municipalities may also establish community improvement plans for certain purposes including transportation corridors and facilities.

Under Section 28(7) of the *Planning Act*, municipalities may make grants or loans to registered owners or tenants of land in the community improvement project area to pay for eligible costs associated with community improvement. Eligible costs include costs related to project feasibility studies, an environmental site assessment, environmental remediation, development, redevelopment, downtown/core area and waterfront revitalization, construction and reconstruction of lands and buildings for rehabilitation purposes (including space conversion, façade improvements, heritage preservation and accessibility) or for the provision of energy efficient uses, buildings, structures, works, improvements or facilities.

Community improvement plans are a useful tool by which a municipality can implement *freight-supportive* objectives and overall better use of infrastructure, as the municipalities may, depending on how the community improvement plan framework is laid out, undertake:

- Improvements to infrastructure works, for both new or existing streets, that assist in achieving *freight-* and *transit-supportive* communities;
- Promotion of redevelopment sites such as brownfields, greyfields, underutilized *employment areas*, or *infill* and intensification sites adjacent to identified priority corridors, to help facilitate a supportive freight network;
- Municipal property acquisition, land assembly and sale of lands to facilitate objectives in identified freight centres and corridors;
- Signage, streetscaping and landscaping improvements that meet the objectives of these Guidelines; and
- Promotion of private investment in priority areas that meet the objectives of these Guidelines.

### 5.2.2 Site Plan Control

Site plan control is a development control tool provided to Ontario municipalities under the *Planning Act*. Site plan control generally addresses the layout and configuration of development lands, and building siting and massing. Once development plans are approved, a site plan agreement is generally provided, which contractually binds the developer to build and maintain a site in accordance with the approved plans, and the terms of the agreement.

The development of a site should consider the interaction of freight movement on and surrounding the development site.

The development of a checklist can be helpful to municipalities when evaluating whether development applications are *freight-supportive*. A sample checklist has been included in Section 5.4 of these Guidelines which can be tailored and used as a resource by municipal planners.

## Strategies

Use site plan review to evaluate *freight-supportive* elements, including:

- The location and design of site access/egress points to ensure that they do not conflict with *pedestrian* and vehicular access to the site;
- The location and design of the parking, loading and unloading zones, to ensure that they do not conflict with *pedestrian*/vehicular areas and internal circulation routes;
- Site/building access and circulation, including orientation, to ensure that buildings help facilitate physical separation between transportation modes;
- Designation of street rights-of-way to facilitate delivery and freight parking for commercial establishment; and
- Consideration of land requirements for the various modes of transportation.

### 5.2.3 Development Permit System

The Development Permit System (DPS) is a land use planning tool which helps to promote development, enhance environmental protection and facilitate key priorities of Ontarians such as community building, brownfield redevelopment, greenspace preservation and environmental protection. The DPS combines the zoning, site plan and minor variance processes into one application and approval process.

The DPS benefits not only municipalities and the community, but also individual land owners by providing a similar level of certainty as exists in zoning, while also providing the added benefits of streamlining, flexibility and the convenience of a one-stop source for planning approvals.

More information on the Development Permit System can be found at <http://www.mah.gov.on.ca/Page5911.aspx>

### 5.2.4 Integration of Transportation Investments and Land Use Planning

Coordinated transportation and land use planning is crucial to ensuring that the *transportation system* can support the transportation needs associated with existing and future developments, including freight needs. Land use patterns and development mixes directly affect the levels of travel between origins and destinations by determining the feasibility of transportation options and accessibility, which ultimately influence travel mode choice. Municipalities should integrate land use planning and transportation investments to increase overall transportation efficiency and optimize the use of infrastructure.

## Strategies

- Coordinate transportation investments with a land use pattern, density and mix of uses that promote minimizing the length and number of vehicle trips and support current and future use of transit and active transportation.
- Support transportation objectives within comprehensive plans, such as official plans and transportation master plans, municipal capital plans and asset management plans that can support freight movement and land use/transportation planning, while recognizing the special opportunities and issues that arise from the needs of the

freight movement industry. The plans should stage their transportation infrastructure to meet the needs of the forecasted growth.

- Prepare transportation plans that recognize how various modes of transportation needs can be met without compromising the efficiency of freight movement.
- Coordinate infrastructure investments, wherever possible, with neighbouring municipalities to ensure that the *transportation system* provides for seamless movement of people and freight.
- Ensure that economic development strategic planning initiatives are developed in tandem with and support transportation investments and land use decisions.

### 5.2.5 Maintenance of an Effective and Efficient Regional Freight Transportation System

An effective and efficient regional freight *transportation system* is needed to ensure consistent and reliable access across the region. Reliable connections to air, rail, and marine terminals throughout the province will improve Ontario's economy by shortening travel times and providing greater integration of the regional roadway network.

#### Strategies

- Work with key stakeholders to analyze needs for freight-intensive land use access.
- Work to reduce the impacts of congestion on freight movement, by ensuring that capacity for freight movement is not restricted.
- Encourage local companies to use technological and operational advancements, such as integrated *logistics* and supply-chain management systems, to ensure global competitiveness.
- Rural municipalities should review their road structure and conditions to ensure that the existing road network promotes efficient freight connectivity.
- Review opportunities to increase investment in regional mobility by developing congestion management processes, applying performance measures to road networks and supporting multimodal systems within their jurisdictional boundaries.
- Protect lands adjacent to transportation facilities for freight-intensive land uses.

### 5.2.6 Prioritization-Based Planning

Municipalities can use prioritization techniques to ensure that the projects selected for implementation match the policies and objectives identified.

This process includes the following elements, each of which should be completed with the continual involvement of stakeholders:

- A review of relevant policy documents and the extraction of key overarching and more detailed objectives;
- The breakdown of wider objectives into more detailed ones, gradually relating them more closely to transport and freight issues;
- A review of all relevant projects, initiatives, and policies;

- The creation of a matrix with objectives set against initiatives, and the development of a scoring system;
- Scoring initiatives using the scoring system, such as creating a colour coded summary of which initiatives score better against the variety of relevant policy objectives; and
- Developing a shortlist of key projects or initiatives.

An extract from the objectives matrix in South East Queensland, Australia, is shown below as an example:

<b>Strategic Objectives</b>	<b>Secondary Objectives</b>	<b>Specific Transport / Connectivity / Freight Needs</b>
Plan a sustainable and integrated freight network	Increase the capacity and flexibility of the freight network	Provide capacity on the metropolitan rail network to support the operation of a broad range of future rail services, and enhance the flexibility of available train paths
		Flexibility of freight movement outside peak times
	Optimise rail and road alignments for quick and efficient travel	Ensure road and rail design accommodates advances in vehicle technology, larger freight efficient vehicles, and increasing traffic volumes
	Disperse peak hour travel pressures through changing travel behaviour	Spreading the peak demand on the freight network

Through the use of an objectives matrix, it is possible, in a collaborative way, to create a priority list that best meets stated objectives. It is also possible to show the links between each individual preferred initiative and the selection of wider policies, and therefore to develop a priority list that each partner should be able to support and promote.

Municipalities should work together with freight operators to generate an agreed priority list for creating *freight-supportive* action plans.

### 5.2.7 Freight Exchanges

Recent advances in technology in freight management can provide additional tools for municipalities, although the necessary methodology needs to be in place to promote and advise rather than to implement the solutions themselves. In partnerships with freight operators, municipalities with significant freight clusters can suggest or promote management tools that operators could develop themselves or contract to specialized third parties.

One good example is the European Freight Exchange (called TRANS – [www.trans.eu](http://www.trans.eu)) which uses a website set up specifically to allow freight operators to ‘match’ trips and loads on roads. Through the website, operators make use of spare capacity by booking space on trucks that are making return trips empty or have available space. TRANS currently operates in 18 European countries.

The benefits associated with using a system similar to TRANS are:

- Better use of trucks that are already on the roads but not completely full, which results in fewer trucks on the road, and ultimately benefits the local environment and quality of life; and
- Freight operators and businesses requiring freight transport and eventual customers also experience a benefit from lower operating costs.

TRANS also provides mapping for routing and for real-time information on the truck's progress to its destination.

Load matching services are currently available in Ontario. One example of a freight exchange website that operates in Ontario is Freighttender.com (see <http://www.freighttender.com/>).

Another example in Ontario is TransCore LinkLogistics (<http://www.transcore.ca/>), which provides load and equipment matching services to an extensive network of carriers, owner operators, freight brokers and intermediaries. TransCore utilizes in-cab satellite tracking, messaging, and engine diagnostics as well as GPS trailer tracking to promote efficiency and satellite networking. The dispatch applications allow for carriers to organize their operations, from entering and dispatching orders through to completing accounting functions.

Municipalities should also seek opportunities to promote freight efficiency through promotion/awareness-building activities for freight exchanges. Examples include advertising load matching services on changeable message signs and links on municipal websites.

*Figure 5.1: An example of the TRANSMap interface, which allows users to identify available trucks, routes and costs associated with shipping freight.*

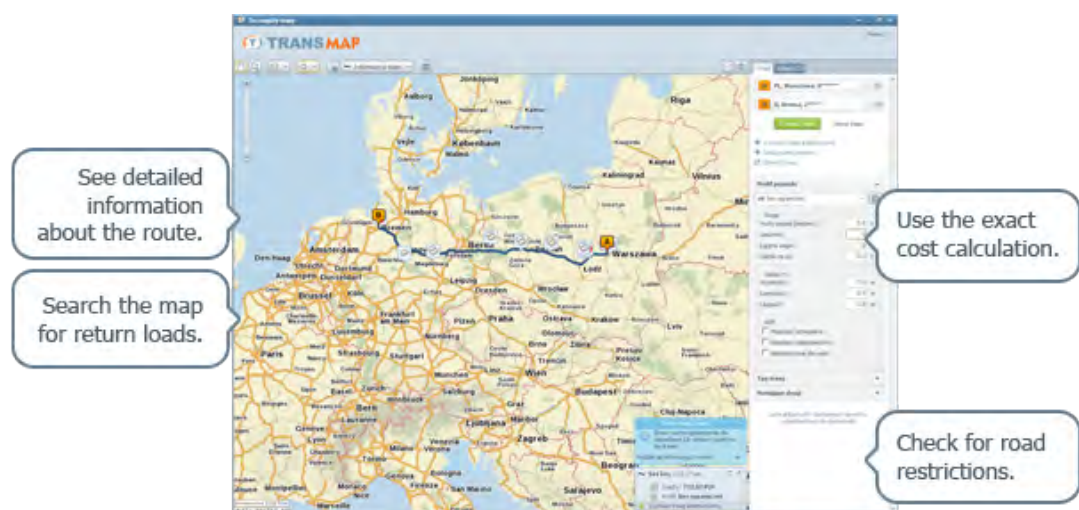

## 5.3 Infrastructure and Technology Investment and Funding Opportunities

### 5.3.1 Data Collection

Data is key to understanding current conditions and making strategic decisions and investments. It is essential for determining the current performance of the *transportation system*, objectively identifying and prioritizing areas requiring improvements, and monitoring the effects of the improvements.

The *freight audit* process is a useful tool by which a municipality can collect data, and measure freight performance. This understanding should be used to inform and define a vision and direction for achieving a sustainable, strong, and adaptive *transportation system*. The vision can be supported by quantifiable (measurable) objectives and performance metrics (statistics), informed by the *freight audit*, and can help synthesize various transportation improvement projects towards a common goal.

#### Strategies

- Establish an industry–government advisory group consisting of a range of stakeholders to obtain input/understanding of freight operations and how they are expected to change in the future. This can also inform municipal solutions and actions;
- Demonstrate best practices for municipal implementation and providing recommendations on congestion and safety, conditions to support economic development, and *harmonization*;
- Promote communication, collaboration and partnerships with neighbouring municipalities, as well as between the public and private sector; and
- Consider developing a data collection system that can assist in effectively evaluating the actions implemented from the priority-based plans.

### 5.3.2 Infrastructure Investment

Infrastructure investment is important to the successful development of a *freight-supportive* community.

#### Strategies

- Conduct a *freight audit* in order to establish a base data set that can be used for a variety of planning purposes and that can be updated on a periodic basis;
- Coordinate freight movement based on freight priorities identified in the *freight audit* and transportation master plans;
- Utilize transportation master plans, asset management plans, and findings from the *freight audit* to determine where new infrastructure investments should be directed; and
- Inventory the *transportation system* so that its performance can be measured. The temporal, spatial, and physical characteristics of truck traffic flows can be measured, bottlenecks can be identified, critical corridors can be defined, and opportunities to increase productivity can be revealed.

### 5.3.3 Technology Investment

Technological investment may be necessary for successful development of a *freight-supportive* community, and the amount of investment should be based on accurate and reliable data.

#### Strategy

- Cooperate with upper tier and neighbouring governments in implementing *Intelligent Transportation Systems* and advanced traffic management systems such as variable message signs.

### 5.3.4 Funding Opportunities

Planning for and creating *freight-supportive* communities requires investment. This has been identified as the most significant challenge with respect to implementing policies and directives that could assist the freight movement industry. The following represent the funding sources that are available in Ontario.

#### Development Charges

The *Development Charges Act, 1997* allows municipalities to levy charges on new development to help finance the growth-related capital costs.

Municipalities must undertake a background study to show estimates and calculations used to establish development charges. The study must include a 10-year growth projection, estimates of future service needs and estimates of the cost of the infrastructure required to provide those services. A municipality may choose to levy a development charge to recoup up to 100% of the capital costs for water supply services, waste water supply services, storm water drainage and control, highways, electrical power, police and fire.

#### Alternative Funding Arrangements

Some of the most successful communities have been developed using alternative funding arrangements, such as:

- **Public-Private Partnerships (P3s)**. P3s describe a government service or private business venture which is funded and operated through a partnership of government and one or more private sector companies. This can be a useful tool for developing *freight-supportive* communities. Municipalities should consider developing partnerships with private establishments where:
  - The transfer of land would be strategic in achieving the objectives of these Guidelines;
  - Proceeds from capital sales could be used to reinvest in capital infrastructure; or
  - The delivery of *freight-supportive* facilities could be done more efficiently by a private party. A municipality can enter into municipal capital facilities agreements with third parties to deliver *freight-supportive* facilities. This can include the provision or leasing of a freight facility and/or the operating or maintenance of the facility on the behalf of the municipality.



- **Municipal Services Corporation.** Through Section 203 of the *Municipal Act, 2001*, municipalities can establish corporations to assist in bringing in capital revenues to deliver infrastructure necessary to promote efficient freight movement. In addition, municipalities have the authority to use an area rate levy, which can be provided to a municipal services corporation for economic development services.
- **Tax Assistance.** Section 365.1 of the *Municipal Act, 2001* allows a municipality to implement a Brownfields Financial Tax Incentive Program (BFTIP) to provide tax assistance for the purpose of encouraging the remediation and reuse of brownfield properties.

## 5.4 Sample Checklist

The following provides a sample checklist that a municipality could consult in order to:

- Help understand the freight system in their jurisdiction;
- Aid in the determination if municipal documents, including official plans, secondary plans, transportation master plans and zoning by-laws are consistent with, and reflect, the overall objectives of the *Freight-Supportive* Guidelines;
- Assist in evaluating new development applications to ensure consideration was given in site design and planning to the movement of freight; and
- Assess freight operation and movement within their jurisdiction.

The following is a sample checklist that municipalities could consider, it is not intended to be comprehensive and would need to be customized by the municipality as needed:

### Freight-Supportive Checklist

Item	Complete			Comments/ Notes
	Y	N	N/A	
<b>Freight Audit</b>				
Has a <i>freight audit</i> been undertaken?				
If so, did it result in identifying major freight movement facilities and networks?				
Have the results and recommendations of the audit been incorporated into planning and transportation policies?				
Have these facilities and networks been communicated with neighbouring municipalities to ensure coordination?				
<b>Land Use and Transportation</b>				
Have the appropriate <i>employment areas</i> in close proximity to freight corridors been protected for future freight industries?				
Have <i>employment areas</i> outside of designated <i>employment areas</i> been considered to encourage redevelopment, reuse and <i>infill</i> ?				
• If these areas are in close proximity to residential areas, have mitigation measures been taken?				
Have development plans been reviewed to determine impact to existing freight corridors and facilities?				
• If impacts exist, have appropriate site design and mitigation measures been proposed to avoid conflicts?				

## Freight-Supportive Checklist

Item	Complete			Comments/ Notes
	Y	N	N/A	
<ul style="list-style-type: none"> <li>Is the location of the project in close proximity to highways, freight facilities (i.e., <i>logistics</i> centres), <i>intermodal facilities</i> (i.e., marine or airports) or railways to promote freight consolidation?</li> </ul>				
<ul style="list-style-type: none"> <li>Does the project conform with truck-related requirements and by-laws of the municipality, neighbouring municipalities and upper tier municipalities to ensure seamless freight movement?</li> </ul>				
Have appropriate freight movement corridors been planned?				
<ul style="list-style-type: none"> <li>Have they been designed to ensure sufficient capacity, turning movement and stability for trucks?</li> </ul>				
<ul style="list-style-type: none"> <li>Does the size of the corridor meet municipal standards, while meeting the needs of the freight industry?</li> </ul>				
<ul style="list-style-type: none"> <li>Have proper signage and pavement markers been provided to ensure wayfinding?</li> </ul>				
<ul style="list-style-type: none"> <li>Have sufficient access points (driveways) been provided?</li> </ul>				
<ul style="list-style-type: none"> <li>Has sufficient mitigation been provided along corridors to protect natural heritage features?</li> </ul>				
<ul style="list-style-type: none"> <li>If by-passes are considered, have they been properly evaluated through the Municipal Class EA Act?               <ul style="list-style-type: none"> <li>Have the potential impacts to traffic, time savings/loss, businesses, development patterns, and costs of developing the by-pass been considered?</li> </ul> </li> </ul>				
<ul style="list-style-type: none"> <li>When selecting a freight movement corridor, has preference been given to:               <ul style="list-style-type: none"> <li>Corridors with dynamic warning systems for downgrading and underpass approaches;</li> <li>Routes with railway crossings where the crossing surface at the railway track is the same plane and distance for one metre outside of the rails;</li> <li>Low-speed corridors with reduced traffic signal cycle times;</li> <li>High-speed corridors with truck priority logic programmed into traffic signals;</li> <li>Minimizing major highways that pass through rural downtowns;</li> <li>Corridors with climbing lanes for long, steep grades;</li> <li>Corridors with emergency escape ramps and downgrade passing lanes; and</li> <li>2+1 roadways that provide buffers between travel directions?</li> </ul> </li> </ul>				
<b>Site Design</b>				
Is the site designed in accordance with design guidelines as set out by the municipality?				
Have CPTED principles been incorporated into the site design?				
Have other users (i.e., <i>pedestrian</i> , cyclists) been considered in the design?				
Has site access been considered, including turning radii, driveway lengths and spacing of access points?				
<ul style="list-style-type: none"> <li>Has a balance been achieved between truck access and access for other site uses?</li> </ul>				
<ul style="list-style-type: none"> <li>Has the fire truck access on site been identified and designed in accordance with the Ontario Building Code?</li> </ul>				
<ul style="list-style-type: none"> <li>Has the location of truck acceleration and deceleration lanes been considered to enable trucks to safely merge and exit sites without impeding traffic?</li> </ul>				
Has special site design been considered for those sites adjacent to <i>sensitive land uses</i> ?				
<ul style="list-style-type: none"> <li>Have buffers, <i>berms</i> and screening been provided to reduce visual, noise and light impact of loading and delivery areas on adjacent uses?</li> </ul>				

### Freight-Supportive Checklist

Item	Complete			Comments/ Notes
	Y	N	N/A	
<ul style="list-style-type: none"> <li>Have garbage/recycling facilities and loading docks/yards been located appropriately ( i.e., centrally) to minimize impacts on adjacent uses and facilitate efficiency and adequate truck movement on site?</li> </ul>				
Has short term drop-off for delivery been provided?				
<b>Operations</b>				
In areas of high truck volumes, have the intersections been adjusted with respect to signal timings?				
If roundabouts are included in the identified freight route, have they been designed to accommodate truck turning movements, specifically, right-turns through extra turning space, right turn aprons or by-pass lanes?				
Does the freight movement corridor utilize intelligent transportation system (ITS) technologies to assist <i>freight audit</i> process by municipality?				



## 6.0 CASE STUDIES

---

The case studies provided in this chapter identify best practices to help guide Ontario municipalities in the application of the Freight-Supportive Guidelines. The case studies provide an overview of an approach to planning, site design, or operational technology, and describe why the case study is relevant to the Ontario context. In keeping with the contents of these Guidelines, case studies are presented for freight audits, planning, site design and operations. The case studies include references to complementary guidelines and, where available, provide references for more information about the case study.





## 6.1 Freight Audit Case Studies

*Freight audits* have been conducted by cities and regions across North America. Although often not specifically called a *freight audit*, these studies and reports contain many elements of a *freight audit*. These may include data collection, field visits, stakeholder consultation, and a written report summarizing the analysis and providing recommendations for future transportation investments. This section provides examples from jurisdictions large and small that have prepared documents similar to *freight audits*. The examples highlight the type of information collected and the importance of the study for freight movement. The *freight audit* case studies complement the *freight audit* guidelines presented in Chapter 2.

### 6.1.1 Regional Municipality of Peel

#### Overview

The Region of Peel is a major centre of freight movement in Ontario. The Region of Peel prepared a Study of Goods Movement in November 2004 to evaluate the current state of the freight industry and transportation infrastructure within the Region, and to identify strategic options that can facilitate freight movement. Mississauga in the south end of the Region contains Pearson International Airport as well as substantial industrial and freight movement activity. Brampton, in the centre of the Region, shares in the airport-related activity and also contains a CN Rail *Intermodal* Yard. Caledon, in the north, contains resource-based industries.

The Study was intended to provide freight movement input into the Regional Official Plan (ROP), as the 2002 ROP Strategy Update only contained two policies on freight movement and there was a desire on the part of the Region to build more freight movement policies into the ROP. The Study of Goods Movement also was one of four studies prepared in advance of the Region's first transportation master plan, the 2005 Long Range Transportation Plan. The Study was conducted by collecting existing data for air, rail, marine and road freight, and identifying the major freight generators and facilities in the Region.

Stakeholder consultation was an important part of this Study. Private industry, non-profit organizations, government staff from municipalities, provincial and federal agencies, and elected officials all were engaged in dialogue regarding freight movement. Approximately 30 shippers and carriers responded to a detailed survey asking participants about their satisfaction with the goods movement network in Peel Region and inviting them to identify Regional issues of concern. A stakeholders forum with 51

#### Location:

Region of Peel, Ontario

#### Population:

1.3 million

#### Planning Scale:

Regional level

#### Applicable Guideline:

2.1 Freight Audit

#### Why this case study is important

This case study highlights an Ontario region whose economy is strongly linked to freight movement. The case study shows how a regional municipality can begin to develop an understanding of the freight industry within its boundaries and define a baseline for on-going assessment of freight mobility. Elements of the process and the policy and program initiatives may be useful to municipalities facing similar challenges.

participants was also conducted with Regional Council, industry and other stakeholders, to identify short and long-term goods movement initiatives.

Based on the background research and consultations, strategic options to improve goods movement in the Region were identified. Recommendations for policy and program initiatives and a set of short-term “next steps” were included in the report to guide further actions in support of goods movement.

## Features

The complete Study can be downloaded from the Region of Peel’s website at:

[http://www.peelregion.ca/planning/transportation/goods\\_mvmnt.htm](http://www.peelregion.ca/planning/transportation/goods_mvmnt.htm)

Key action areas recommended in the Study included:

- Developing partnerships with government and industry;
- Developing a goods movement network, based on understanding of the activity centres and corridors in the Region;
- Addressing major issues on the corridors, including traffic congestion and impacts on adjacent communities, such as noise, safety and accessibility;
- Improving data and integration of the freight network into the Region’s overall Transportation Plan;
- Coordinating policies, and focusing on sustainable freight movement transportation; and
- Collaborating between stakeholders to fund improvements which will help improve freight movement.

Since the Study was completed, the Peel Goods Movement Task Force, comprised of public and private stakeholders, was established to guide and plan for the implementation of future improvements to the goods movement system in Peel Region. The task force is advancing items identified in the Goods Movement Strategic Plan, which was approved by Regional Council in April 2012.

Figure 6.1: Trucking activity in the Region of Peel





## 6.1.2 Delaware Valley Regional Planning Commission (Philadelphia, Pennsylvania Metropolitan Area)

### Overview

The Delaware Valley Regional Planning Commission (DVRPC) is the metropolitan planning organization for the Philadelphia Region. The DVRPC consists of 352 municipalities in nine counties stretching across the States of Pennsylvania and New Jersey, and is home to over 5.5 million people. The Region contains many major freight facilities, including the Port of Philadelphia, Philadelphia International Airport and multiple interstate highways, rail lines and over a dozen *intermodal facilities*. The DVRPC conducted “County Freight Scans” in 2009 and 2010 for the nine counties that are part of the DVRPC. The purpose of the County Freight Scans was to provide county planning agency staff with increased information and understanding of freight trends, and to help build capacity to address freight issues.

The tasks involved in producing each of the County Freight Scans included:

- Review of the freight element of the county comprehensive plan;
- Meetings with stakeholders;
- Preparation of county-specific freight data;
- Field visits to freight facilities to understand demand patterns and operational issues;
- Documentation of supply chain case studies showing how goods are produced in the county and then shipped to customers by different freight modes; and
- Mapping major transportation facilities, freight generators, and special areas, such as Foreign Trade Zones.

Once completed, DVRPC distributed the County Freight Scans to the DVRPC’s 352 municipalities.

### Features

The County Freight Scans:

- Provide guidance for local governments attempting to balance freight operations with community goals, plans, and projects;
- Serve as a basis for the preparation of a set of county-specific and regional initiatives that can inform future transportation studies and system improvements;
- Educate planners and engineers on the process of transporting freight from manufacturing centres within the county to markets locally, nationally and internationally; and
- Were distributed to planners and engineers in 352 municipalities.

#### Location:

Philadelphia, Pennsylvania metropolitan area

#### Population:

5.5 million

#### Planning Scale:

Regional level

#### Applicable Guideline:

2.1 Freight Audit

### Why this case study is important

This project is a good example of a *freight audit*, as described in Chapter 2. The process to produce the County Freight Scans included data collection, field visits, stakeholder consultation and mapping of important freight facilities. The project also gives a good example of how to distribute the final reports, as the information collected was distributed for use to all municipalities within the region.

The nine County Freight Scans can be accessed from the DVRPC’s website at:

<http://www.dvrpc.org/freight/countyfreightscans/>

Figure 6.2: Freight activity in the Delaware Valley

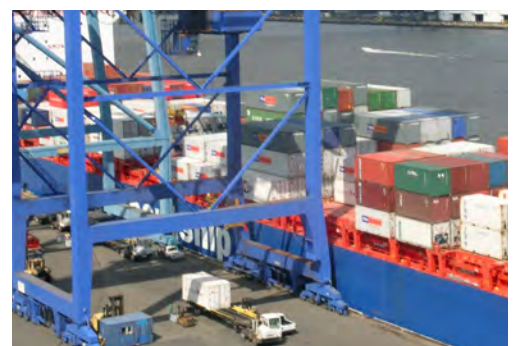

### 6.1.3 Hampton Roads Planning District Commission, Virginia

#### Overview

**Location:**

Southeastern Virginia

**Population:**

1.6 million

**Planning Scale:**

Regional level

**Applicable Guideline:**

2.1 Freight Audit

#### Why this case study is important

This case study shows how a region that depends on freight movement for a portion of its economy is taking steps to plan for freight mobility. The Region is fortunate to have a multimodal freight system and is looking to make the most of the available infrastructure in an effort to secure a positive economic future for the local freight industry. The case study also shows how freight related to military facilities can be incorporated into the freight planning process.

The entire 2012 Study Update can be accessed online at:

[http://www.hrtpo.org/uploads/t12\\_12.pdf](http://www.hrtpo.org/uploads/t12_12.pdf)

Figure 6.3: Norfolk International Airport, Virginia



The Hampton Roads Planning District Commission is the metropolitan planning organization for 16 jurisdictions and 1.6 million people in southeastern Virginia. The area is home to many facilities important to freight movement, including:

- Major U.S. military bases and associated facilities;
- Norfolk International Airport;
- Newport News / Williamsburg International Airport;
- Port of Virginia, which is the third largest seaport on the east coast of the United States;
- Four major railroad lines; and
- A network of highways.

The Commission produced a Regional Freight Study in April and produced an update to the Study in 2012. The Study reviewed the existing freight facilities in the 16 municipalities that are under the jurisdiction of the Planning Commission, and linked freight planning to the regional planning process. Due to the significant presence of U.S. military facilities in this region, special attention was paid to military freight.

The future freight needs were identified for water, air, rail and road transportation. The Study ended with a summary of the existing conditions and expected future needs. The recommended next step was to develop an action plan for implementing transportation improvements.

#### Features

- Integrated freight planning into the overall transportation planning process;
- Collected freight data that can be used in other analyses for other planning purposes;
- Considered the impact of military-related freight; and
- Identified future needs for the seaport, airports, rail and highways to support freight movement.

## 6.1.4 Rappahannock – Rapidan Regional Commission, Virginia

### Overview

The Rappahannock-Rapidan Regional Commission is the planning body for 165,000 people in five counties in rural Virginia. Freight primarily is moved by truck in the Region, using two interstate highways and a series of U.S. and state highways. The use of other modes for freight movement is limited to two freight railroad lines in the Region. There is no seaport for this land-locked region and there are no airports that support commercial aviation for air cargo.

As part of its efforts to prepare its Long-Range Transportation Plan, the Commission prepared a Freight Physical Infrastructure Profile in 2009. This Report was one of four reports on freight, which also included:

- Freight Movement Profile;
- Survey of Major Shippers; and
- Project Analysis and Recommendations.

The work on freight planning was important because it was expected to help ensure that freight-related issues were addressed and planned for in the long-range transportation planning documents.

### Features

The work to prepare the Freight Physical Infrastructure Profile included an identification of:

- Regionally significant freight facilities (mostly roadways);
- Current problems in the transportation system;
- Available capacity;
- Planning and programmed improvements; and
- Additional opportunities to support and improve the freight network.

#### Location:

Central Virginia

#### Population:

165,000

#### Planning Scale:

Regional level

#### Applicable Guideline:

2.1 Freight Audit

### Why this case study is important

This case study shows that a smaller, rural region with limited financial resources can undertake a *freight audit* and produce a report that will support freight movement.

More information on long-range transportation planning in the Rappahannock-Rapidan Regional Commission can be found at:

<http://www.rrregion.org/longrangeplan.html>

## 6.1.5 Spartanburg Area Transportation Study, South Carolina

### Overview

**Location:**

Spartanburg County, South Carolina

**Population:**

280,000

**Planning Scale:**

County level

**Applicable Guideline:**

2.1 Freight Audit

### Why this case study is important

This case study shows that a county of medium-sized population outside of a major metropolitan area can undertake a *freight audit* in an effort to support long range transportation planning and to promote economic development.

More information about long-range planning in Spartanburg can be found at:

<http://spatsmpo.org/>

Figure 6.4: Aerial view of Spartanburg, South Carolina



The Spartanburg Area Transportation Study plans for the 280,000 people living in Spartanburg County, South Carolina. The City of Spartanburg is the largest city in the county, with approximately 40,000 residents. The county is located along an interstate highway (Interstate 85) between Atlanta, Georgia, and Charlotte, North Carolina. It is also crossed by Interstate 26, which provides access to the seaport at Charleston. In 2010, the organization prepared a Freight Supply and Demand Analysis for Spartanburg to evaluate freight movement by truck, rail and air that was going towards, or passing through, the county.

In the Study, information about the supply of freight infrastructure was collected and analyzed to determine gaps, weaknesses and opportunities. In the demand side of the Study, existing freight data was collected and compared to future projections of freight movement through the county.

### Features

- The Study identified the importance of freight and how it fits into the overall planning framework, to ensure that freight-related issues are addressed and considered appropriately in the selection of projects;
- The Study included data stating the amount and the value of freight going out of, into and through the County, which will help the County to properly reflect the importance of freight movement in its long-range transportation planning exercises; and
- Greater coordination of the County's freight network was recommended between Spartanburg County and the State, as the main truck routes in the County are maintained by the State.

## 6.2 Land Use and Transportation Planning Case Studies

The planning case studies include standalone documents as well as documents that form part of a body of work on long range transportation planning. All of the case studies profiled here seek to bring freight to the forefront of planning for infrastructure investments.

### 6.2.1 City of Ottawa Truck Routes Designation Policy

#### Overview

The City of Ottawa prepared a Truck Routes Designation Policy in October 2005 in order to harmonize truck routes across the city and to bring all parts of the recently amalgamated city under one standard policy. The Policy was developed with input from the National Capital Commission and members of the Ontario Trucking Association, the former Transportation Advisory Committee and the Agriculture and Rural Affairs Committee, in addition to City staff.

The Policy included criteria to be applied to assess existing and proposed road links for their suitability as designated truck routes. These included: system/network criteria; physical characteristics of the road; and environmental criteria.

The truck route designation guidelines indicate the appropriateness of truck routes given the road classification and surrounding land use (central area, general urban area, rural area, employment and enterprise area and villages).

#### Features

- Truck routes have been designated for both urban and rural portions of the city;
- Truck routes are indicated for full loads and restricted loads (5 tonnes per axle during the spring thaw period);
- The truck routes are incorporated into the Transportation Master Plan (TMP) and undergo a comprehensive review as part of each TMP update; and
- The truck route maps are updated annually based on current pavement/structure condition and/or new construction.

#### Location:

Ottawa, Ontario

#### Population:

883,000

#### Planning Scale:

City level

#### Applicable Guidelines:

2.1 Freight Audit

4.4 Requirements, By-Laws, Policies, and Practice, specifically Guideline 4.4.2

#### Why this case study is important

This case study shows how a city in Ontario has taken a proactive approach to provide truck routes to support freight movement. The truck routes address both urban and rural settings within the city boundaries.

**The Urban Truck Routes map can be downloaded from:**

[http://documents.ottawa.ca/sites/documents.ottawa.ca/files/documents/urban\\_truck\\_routes\\_en.pdf](http://documents.ottawa.ca/sites/documents.ottawa.ca/files/documents/urban_truck_routes_en.pdf)

**The Rural Truck Routes map can be downloaded from:**

[http://documents.ottawa.ca/sites/documents.ottawa.ca/files/documents/rural\\_truck\\_routes\\_en.pdf](http://documents.ottawa.ca/sites/documents.ottawa.ca/files/documents/rural_truck_routes_en.pdf)

## 6.2.2 FAST Corridor

### Overview

The Freight Action Strategy for the Everett-Seattle-Tacoma Corridor (FAST Corridor) is a partnership of 26 local cities, counties, ports, federal, state and regional transportation agencies, railroads and trucking interests that is working together to address freight mobility in the Puget Sound Region of the State of Washington. The FAST Corridor extends from the Port of Tacoma in the south, to the Port of Seattle and onwards to the Port of Everett in the north. Together, these three ports represent the third largest marine container load centre in the United States. They are supported by two major rail lines and a network of highways. The freight network in the Puget Sound Region is important on the local, regional, state and national level for the jobs it provides and the freight shipped back and forth to Asian markets.

Through the partnership working together and gaining funding from both public and private sources, nine of the 25 priority projects identified in the Corridor have been constructed. The remaining projects address:

- Grade separation of rail lines;
- Direct highway access to the ports;
- Capacity improvements on highways; and
- Intelligent Transportation System (ITS) measures to address congestion near the ports of Seattle and Tacoma.

### Features

- The partnership has been working to support freight mobility since 1998;
- Projects have been constructed using both public and private funding; and
- The projects address freight mobility and in turn also help general mobility by removing bottlenecks/blocks and establishing safe rail crossings and reliable truck routes.

#### Location:

Seattle, Washington metropolitan area

#### Population:

3.7 million

#### Planning Scale:

Regional level

#### Applicable Guideline:

2.0 Land Use and Transportation  
Planning Guidelines

### Why this case study is important

This case study demonstrates the value of a public/private partnership that has used public and private funding for strategic freight mobility infrastructure improvements. Projects have been constructed and more projects have been identified for construction once funding is available.

More information on the FAST corridor is available at:

<http://psrc.org/transportation/freight/fast>

Figure 6.5: FAST Partnership informational brochure cover



## 6.2.3 Freight Quality Partnerships

### Overview

Freight Quality Partnerships (FQP) have been established across the United Kingdom between the freight industry, government and interested stakeholders. An example of an FQP is in the Newton Abbot area of Devon County. This area is mostly rural with a few small towns, centred on Newton Abbot. Before the creation of the FQP, concern had been increasing in government as well as among the business community about the impact of trucks on the communities in the County. Newton Abbot was selected as a place of particular concern due to traffic congestion and the resulting traffic delays.

The FQP was formed to address a number of issues relating to freight movement, including:

- Making the most of the existing transportation network and to identify the best routes for truck traffic;
- Reducing the damage to roads and pavement by identifying the maximum truck size for specific routes;
- Promoting other means of freight transport such as rail and sea;
- Improving safety between trucks and *pedestrians*, cyclists and other road users;
- Promoting research into creative, new ways to distribute and deliver goods and the possibility of freight transfer depots;
- Making the most use of modern high specification vehicles to promote efficiency and lower vehicle emissions;
- Improving air quality and lowering the amount of noise, vibration and disturbance from freight movements; and
- Monitoring the effects of different actions.

The FQP surveyed the community and worked to identify solutions to concerns raised relating to freight movement. The FQP prepared an action plan with specific tasks and timelines for implementation of the identified solutions.

#### **Location:**

Newton Abbot area of Devon County, United Kingdom

#### **Population:**

92,000

#### **Planning Scale:**

Regional level

#### **Applicable Guideline:**

2.0 Land Use and Transportation  
Planning Guidelines

### Why this case study is important

This case study shows how a rural area with small towns can bring stakeholders together and create benefits to the freight industry. By assisting the freight industry, the larger community has also benefited through more efficient delivery of freight and safer conditions for the delivery of freight.

More information about FQP in Devon County is available at:

[http://www.devon.gov.uk/index/transportroads/traffic/traffic\\_management/freight\\_quality\\_partnerships.htm](http://www.devon.gov.uk/index/transportroads/traffic/traffic_management/freight_quality_partnerships.htm)

Figure 6.6: Driver information sheet, Newton Abbot

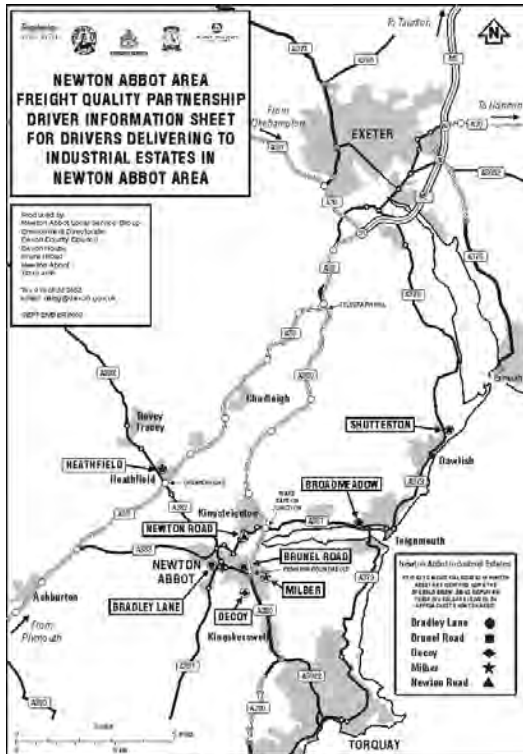

## Features

The FQP has implemented a number of the identified solutions in support of freight movement, including:

- Maps of suitable routes for truck deliveries, distributed to local businesses who in turn can provide them to their suppliers;
- Improvements to loading bay areas along the main commercial street in Newton Abbot;
- Truck parking enforcement to ensure that truck parking areas are used by trucks only;
- Information boards to direct drivers at large industrial sites; and
- Installation of traffic signals at a major industrial facility.

Figure 6.7: Loading bay in a densely developed small downtown in the United Kingdom





## 6.2.4 Atlanta Regional Freight Mobility Plan

### Overview

The Atlanta Regional Commission (ARC) is the regional planning body for ten counties and over 4 million people in the Atlanta metropolitan area. Atlanta is the centre of freight operations in the southeastern United States and is one of the three largest inland distribution centres in the nation. Three major interstate highways cross through the Region and two major rail operators service the Region. The international airport in Atlanta is the busiest in the world in terms of air passengers and also plays an important role in national and international air cargo. With severe congestion on the highways in the evening peak hour, and recognizing that 88% of the freight tonnage shipped in the Atlanta Region moves by truck, the ARC prepared the Atlanta Regional Freight Mobility Plan in February 2008 to identify and prioritize transportation improvements to accommodate mobility of both people and freight while lowering the occurrence of the negative impacts on congestion, safety, and communities.

The process to produce the Plan included:

- Data collection;
- Needs assessment;
- Land use assessment;
- Community and environmental impact scan and assessment; and
- A regional economic assessment.

Stakeholder consultation was also completed. Through the data analysis and stakeholder input, existing conditions were determined. Future conditions were predicted and an evaluation of transportation improvements needed to meet future conditions was undertaken. All of the analysis was considered in the development of the freight mobility plan strategies and recommendations, with the final product being an implementation plan.

### Features

- A principal recommendation of the Plan was the establishment of a Priority Freight Highway Network (PFHN);
- Since the adoption of the plan, ARC has been working on a strategic truck route master plan to address issues in truck routing and operations within the Atlanta region; and
- ARC is addressing inter- and intra-regional freight movement.

#### Location:

Atlanta, Georgia metropolitan area

#### Population:

4 million

#### Planning Scale:

Regional level

#### Applicable Guideline:

2.0 Land Use and Transportation  
Planning Guidelines

### Why this case study is important

The Atlanta Region is a major freight centre that has taken proactive planning measures to ensure that the freight industry is supported. The road network in the Region is radial out of the Atlanta downtown area and does not accommodate cross-town truck movements. ARC is continuing its work to produce a truck route master plan to identify and promote truck routes and to plan for improvements for inter- and intra-regional freight movement as well.

#### The entire Report can be accessed online at:

[http://documents.atlantaregional.com/transportation/freight/Freight\\_Mobility\\_Plan\\_Final\\_Report\\_Feb%206\\_%202008.pdf](http://documents.atlantaregional.com/transportation/freight/Freight_Mobility_Plan_Final_Report_Feb%206_%202008.pdf)

## 6.2.5 Metropolis Freight Plan

### Overview

**Location:**

Chicago, Illinois metropolitan area

**Population:**

8.2 million

**Planning Scale:**

Regional level

**Applicable Guideline:**

2.0 Land Use and Transportation  
Planning Guidelines

### Why this case study is important

The importance of the Plan discussed in this case study is that it was led by private business. The process to create the Plan brought together business, government and advocacy groups to form an agreement on the vision for freight movement in the region. The broad support of the Plan will help ensure its implementation.

The entire Metropolis Freight Plan can be viewed at:

<http://www.metropolisstrategies.org/documents/MetropolisFreightPlan.pdf>

The Metropolis Freight Plan for the Chicago metropolitan region is an example of private industry leading the effort to ensure freight mobility in a region. Metropolis Strategies, which developed the Plan, is a membership organization originally created by the Commercial Club of Chicago. The organization supports regional planning and infrastructure investment.

Chicago historically has been the freight capital of the United States and is the only city served by the six largest North American railroads. The region is home to 73 *intermodal* terminals that allow for the transfer of freight between transport modes, most often between rail and truck. The extensive network of highways and rail lines in the region are becoming more and more congested.

The creation of the Plan was led by a senior project team that worked with freight professionals. The work of the professionals was reviewed by an advisory council that comprised private, government and non-governmental organizations. Communication with private industry and government agencies was completed. The Plan promotes a coordinated, regional approach to maintain and strengthen facilities important to freight.

### Features

Metropolis Strategies recognized the importance of efficient freight movement to the economic competitiveness of the region and developed the Metropolis Freight Plan, which provided a series of recommendations to improve freight movement. Recommendations include:

- Creation of a regional policy board that would be a single accountable transportation and planning agency responsible for the needs of the community across the region;
- Creation of a county planning organization, governed by county and municipal staff to coordinate development and transportation plans within the county jurisdiction; and
- Designation of the State of Illinois Department of Transportation as the agency responsible for coordinating state-wide freight policies and programs.

## 6.2.6 Portland Metro Regional Freight Plan 2035

### Overview

The Portland, Oregon metropolitan area plays an important role in freight movement for the northwestern United States and is home to an international airport, seaport, and multiple interstate highways and rail lines. Portland is a leading U.S. port in the export of grain as well as other agricultural products.

The Portland region is known for its commitment to sustainability and green business practices. Portland Metro Regional Freight Plan 2035, finalized in 2010, is a long-range plan that addresses multimodal freight operations and that seeks to maintain the competitive advantage in sustainable multimodal options for freight movement. The Regional Freight and Goods Movement Task Force, a 33 member task force including representatives from the freight industry, community and government agencies, guided the formation of policy and strategy recommendations. The Plan includes a freight strategy toolkit to help implement the Plan as well as an action plan on how to achieve the goals of:

- Multimodal system planning for freight mobility and access;
- System management to increase network efficiency;
- Public understanding of freight and goods movement issues;
- Sustainable freight transportation systems;
- Freight-sensitive land use planning; and
- Strategic transportation investments.

### Features

- The 2010 Regional Freight Mobility Plan built upon other planning work, including:
  - 2000 Regional Transportation Plan; and
  - Freight planning at the city and state level.
- The Regional Freight and Goods Movement Task Force, consisting of representatives from government agencies and private industry, guided the formation of policy and strategy recommendations; and
- Keeping with the Region's reputation as a place for creative, environmentally friendly design, a focus of the Plan was on sustainability.

#### Location:

Portland, Oregon metropolitan area

#### Population:

1.5 million

#### Planning Scale:

Regional level

#### Applicable Guideline:

2.0 Land Use and Transportation  
Planning Guidelines

### Why this case study is important

This plan was prepared during the global economic crisis when freight volumes had decreased from historical levels. The Plan was designed to position the Portland region for the rebound in the freight movement economy and for any structural changes that may result after the economic crisis has ended.

The entire Report can be accessed online at:

[http://library.oregonmetro.gov/files/regional\\_freight\\_plan\\_june\\_10.pdf](http://library.oregonmetro.gov/files/regional_freight_plan_june_10.pdf)

## 6.2.7 Linking Critical Freight Facilities

### Overview

#### Location:

32km corridor between the Ports of Los Angeles and Long Beach and downtown Los Angeles, California

#### Population:

70,000 people living within 150 metres of the corridor

#### Planning Scale:

Corridor level

#### Applicable Guidelines:

- 2.2 Protecting Employment Areas and Freight Facilities, specifically Guideline 2.2.1
- 4.3 Freight Gateways, specifically Guideline 4.3.1
- 5.2 Implementation Tools, specifically Guidelines 5.2.4 and 5.2.5

### Why this case study is important

The Alameda Corridor, which took years to plan and billions of dollars to construct, remains a success story that shows how freight facilities important to the national freight movement system can be linked for the benefit of all stakeholders. Vision at the government regional planning level led to the creation of a committee that worked to address a pressing concern that was, and remains, important to the economic success of the region. Through broad support from numerous stakeholders, the vision became a reality. Multiple benefits have resulted for communities along the Alameda Corridor and the freight industry.

The Alameda Corridor is a dedicated rail corridor in Los Angeles, California, that links the Ports of Los Angeles and Long Beach with the main railway yard in downtown Los Angeles, about 32 kilometres north of the ports. The Alameda Corridor is grade separated to eliminate conflicts with private vehicles, transit, cyclists and *pedestrians*. The Corridor also reduces the number of trucks on highways and city streets by enabling freight from the ports to move to the rail lines without the need of trucks. The Alameda Corridor is playing an important role in helping to lower pollution and congestion related to truck traffic. It also has provided a reliable and efficient linkage of important freight movement facilities.

The Alameda Corridor was 20 years in the making, beginning with the Ports Advisory Committee established by the Southern California Association of Governments in 1981. A large group of stakeholders from multiple levels of governments as well as the freight industry played an active role in this and other committees, as options to improve freight movement were identified and analyzed. The Alameda Corridor Transportation Authority was established in 1989 as a Joint Powers Authority to oversee the design and construction of the Alameda Corridor.

### Features

The Alameda Corridor opened in 2002 at a cost of U.S. \$2.4 billion. It has been a success on many fronts, including:

- Increasing the volume of freight that can be transported between the ports and the downtown Los Angeles rail yards;
- Providing a reliable means to speed up the transfer of freight from the ports to the rail lines; and
- Eliminating 200 at-grade crossings, which improved mobility on the local street network and reduced delays and the air pollution associated with delays.

Building on this success, additional improvements around the Ports of Los Angeles and Long Beach are underway. An Alameda Corridor East Construction Authority also has been formed to continue the success of the Alameda Corridor by working on rail improvements on the rail lines heading east from downtown Los Angeles to the edge of the Los Angeles metropolitan region in order to reduce the number of at grade crossings, improve transportation mobility for all users in the region, improve reliability of travel time for freight and reduce pollution caused by delays.

Figure 6.8: Alameda Corridor



More information on the Alameda Corridor is available at:

<http://www.acta.org/about/history.asp>

More information on the Alameda Corridor East Construction Authority is available at:

<http://www.theaceproject.org/>

## 6.3 Site Design Case Studies

The site design case studies highlight two examples where guidelines have been prepared to accommodate a chain of retail stores, and where guidelines provide safety mechanisms in the site design to alert pedestrians of truck traffic.

### 6.3.1 Retail Design Guidelines

#### Overview

Companies with multiple locations may develop design guidelines for use in constructing their facilities in a similar way and to specifications that will suit their business. An example of this is Shoppers Drug Mart. Shoppers Drug Mart has grown into a chain of almost 1,200 stores across Canada.

Shoppers Drug Mart stores are located within indoor shopping malls, in strip mall commercial plazas, mixed-use buildings in downtown commercial cores and in standalone buildings in “main street” urban settings. Their design guidelines are flexible to accommodate different types of store locations. Implementing the guidelines ensures that the stores will have enough loading dock facilities for receiving goods, enough space to display the goods and services within the store, and parking and landscaping designed to attract customers.

#### Features

The design guidelines address:

- Parking lot, paving and landscaping;
- Receiving/loading dock facilities; and
- Building specifications.

#### Location:

Retail sites throughout Canada

#### Population:

Urban, suburban and rural

#### Planning Scale:

Site level

#### Applicable Guideline:

3.4 Retail Sites

#### Why this case study is important

This case study shows how the use of site design guidelines can streamline the development of multiple sites and provide the facilities needed to run businesses successfully. While this example is a retail site, similar principles could be applied to office, industrial, institutional and high-rise apartment sites.

Figure 6.9: Shoppers Drug Mart



## 6.3.2 Loading Bay Warning System

### Overview

The Victoria Square Shopping Centre is an indoor shopping mall with retail shops, restaurants, a movie theater and over 100 apartment units located in downtown Belfast, United Kingdom. Due to its city centre location, access to the loading bays that service the retail shops is through a narrow public road that also experiences high levels of *pedestrian* traffic. In order to improve safety and alert *pedestrians* of on-coming truck traffic, a Wireless Vehicle Detection System is installed into the roadway through embedded Light Emitting Diode (LED) road studs. As a vehicle approaches the road studs, it is detected and the road studs flash brightly, providing a clear and distinct indication of a hazard to *pedestrians*.

### Features

- Light Emitting Diode (LED) road studs alert *pedestrians* of an approaching vehicle; and
- This measure is useful for areas of high truck/*pedestrian* interaction, but could also be used across freight depots or other locations where there is a risk of multimodal interaction.

**Location:**

Belfast, United Kingdom

**Population:**

270,000

**Planning Scale:**

Site level

**Applicable Guideline:**

3.9 Site Design to Coordinate Freight Transportation with Public Transit, Cyclists and Pedestrians, specifically Guideline 3.9.3

### Why this case study is important

This case study shows an innovative use of technology to help reduce conflict between trucks and pedestrians and improve safety within a busy retail site. The principles in this case study can be applied to other types of sites as well, such as downtown office buildings.

## 6.4 Road Design and Operational Case Studies

The operations case studies highlight successful efforts to improve freight delivery times and improve the safety of freight movement by using dedicated freight facilities and truck driver education plans. Integrated *logistics* centres also are discussed as another way to increase the efficiency of freight movement.

### 6.4.1 Truck Driver and Bicycle Awareness Scheme, London, UK

#### Overview

The borough of Lambeth in London has led the way in increasing awareness of hazards for both truck drivers and cyclists. Lambeth Council run training days in which truck drivers are educated in bicycle efficiency and are put through simulation situations with truck use. The truck drivers are taken out on to the streets of the city on bicycles in order to gain a cyclists' perspective. Likewise, cyclists are given cycling efficiency training and are also given a demonstration of sitting in the cabs of trucks to show the restrictions on views for the driver.

#### Features

- Truck driver education in the classroom;
- On-street truck driver education with the truck drivers riding bicycles to get the cyclist's perspective; and
- On-street cyclist education allowing cyclists to sit behind the wheel of a truck to understand the truck driver's view of the road.

Figure 6.10: Truck driver and bicyclist in the United Kingdom



#### Location:

Lambeth Borough, London, United Kingdom

#### Population:

272,000

#### Planning Scale:

District level

#### Applicable Guideline:

2.3 Planning for the Freight Movement Network, specifically Guideline 2.3.7

#### Why this case study is important

This case study shows a way to increase truck driver awareness of cyclists through education and on-street training. The case study shows how both truck drivers and cyclists are approached in order to achieve the greatest benefit from the safety awareness training.

More information about the truck driver and cyclist awareness scheme is available at:

<http://www.lcc.org.uk/index.asp?PageID=1442>

<http://www.lcc.org.uk/index.asp?PageID=1911>

## 6.4.2 Integrated *Logistics* Centres

### Overview

**Location:**

Calgary, Alberta and Regina, Saskatchewan

**Population:**

1.1 million (Calgary) and 193,000 (Regina)

**Planning Scale:**

Site level

**Applicable Guideline:**

4.3 Freight Gateways, specifically Guideline 4.3.2

### Why this case study is important

This case study shows how the two main rail operators in Canada are combining operations into integrated logistics centres to increase efficiency and meet customer needs. Municipalities can support the formation of these facilities through zoning and the development approval process.

**More information on the CN integrated logistics centre is available at:**

<https://www.cn.ca/en/media/2013/01/cn-opens-new-intermodal-terminal-at-calgary-logistics-park>

**More information on the CP move to the integrated logistics centre in Regina is available at:**

<http://www.cpr.ca/en/investors/cp-regina-intermodal-facility-opening>

Canadian National Railways (CN) is planning to build an integrated *logistics* centre near Calgary. CN's existing Calgary Yard will be moved to the new integrated *logistics* centre. The *logistics* centre will include:

- Transload and warehouse facility for steel and lumber;
- Automotive compound;
- Liquid/bulk transload and distribution facility;
- Warehousing;
- Container storage; and
- Associated support facilities.

Space also has been provided at the *logistics* centre for CN customers to custom build their own facilities.

Canadian Pacific Railways (CP) is planning to relocate its Regina operations to a new Global Transportation Hub (GTH) that will allow for expanded operations and improvements in the efficiency of freight movement. The GTH will increase integration of rail and truck modes and provide room for CP to grow its operations in the Regina area.

The role of municipalities in the creation of integrated *logistics* centres is to zone land suitable for these types of centres and then provide a development approval process that allows these types of centres to be permitted for development.

### Features

- Large amount of dedicated land zoned for *intermodal facilities*;
- Proximity to rail and highway routes; and
- Governments provide a streamlined approval process.



### 6.4.3 Freight Consolidation Centres

#### Overview

Freight Consolidation Centres aim to reduce single deliveries by providing a facility where smaller truck loads can be combined with other loads and then delivered to a shared final destination. This results in fewer trips to the final destination, which can help reduce congestion and can save costs for the freight industry and their customers. Freight consolidation centres can be particularly effective where low impact vehicles (such as electric vehicles) are used for the final delivery journey.

One example of a freight consolidation centre is the Heathrow Consolidation Centre (HCC), which services London Heathrow Airport, the busiest airport in Europe based on passenger volumes. The HCC creates significant reductions in congestion and carbon emissions as part of the Heathrow City *Logistics* strategy. The process provides airport retailers with an easier and quicker turnaround of stock as the HCC manages all airside security with deliveries made directly to stores. By consolidating 700 deliveries a week into 300, the centre achieves significant environmental and operational benefits.

Similar to the integrated *logistics* centres, the role of municipalities in the development of freight consolidation centres is to zone land for these purposes and to ensure that the development approval and permitting process is transparent so that these types of centres can be developed in a timely manner.

#### Features

- Proximity (2.5 kilometres) to London Heathrow Airport;
- Consolidates deliveries, reducing total number of deliveries to the airport by half;
- Reduces congestion and carbon emissions; and
- Streamlined delivery process with airside security.

#### Location:

Near London Heathrow Airport, London, United Kingdom

#### Population:

Servicing the busiest airport in Europe based on passenger volumes

#### Planning Scale:

Site level

#### Applicable Guideline:

4.3 Freight Gateways, specifically Guideline 4.3.2

#### Why this case study is important

This case study shows an example of how consolidating freight operations can have benefits to multiple stakeholders. This example highlights how freight movement has become more efficient using fewer vehicles, which serves freight customers well. The general public also benefits from fewer trucks on the road.

#### More information on the Heathrow Consolidation Centre is available at:

<http://postandparcel.info/29775/news/dhl-wins-major-contract-extension-for-heathrow-consolidation-centre/>



# 7.0 REFERENCES

---

This chapter contains the acknowledgements, data references, and photo credits.



CHAPTER 2

CHAPTER 3

CHAPTER 4



## 7.1 Acknowledgements

These Guidelines were produced by the Ministry of Transportation in collaboration with provincial ministries and agencies, municipalities, federal government, academia, associations, agencies and industry partners. The following organizations are acknowledged for their significant contribution to the 2016 Freight-Supportive Guidelines:

- **Consultant Team** – MMM Group and MORR Transportation Consulting Ltd.
- **Provincial ministries and agencies** – Ministry of Municipal Affairs and Housing, Ministry of Economic Development, Employment and Infrastructure, Ministry of Environment and Climate Change, Ministry of Natural Resources and Forestry, Ministry of Tourism, Culture and Sport, Ministry of Agriculture, Food and Rural Affairs, Ministry of Northern Development and Mines, Metrolinx
- **Associations** – Association of Municipalities of Ontario, Municipal Engineers Association, Ontario Professional Planners Institute, Southern Ontario Gateway Council, Ontario Good Roads Association
- **Municipalities** – Durham Region, Peel Region, York Region, Halton Region, Waterloo Region, City of Mississauga, City of Ottawa, City of Windsor, City of Toronto, City of Hamilton, City of Brampton, City of Kingston, City of Cornwall, City of London, City of Kenora, City of Dryden, City of Greater Sudbury, City of Sault Ste. Marie, City of Thunder Bay, City of Sarnia, Town of Caledon, United Counties of Stormont, Dundas and Glengarry
- **Federal Government** – Transport Canada, Canada Post
- **Academic** – University of Waterloo, McMaster Institute for Transportation and Logistics
- **Economic Development** - Ontario East Economic Development Corporation, Canadian National Business Development, Toronto Board of Trade, Ontario Chamber of Commerce, Hamilton Chamber of Commerce
- **Rail** – Canadian Pacific, Canadian National Intermodal, Railway Association of Canada
- **Marine** – Hamilton Port Authority, Toronto Port Authority, Port of Thunder Bay
- **Air** – Airport Management Council of Ontario, Greater Toronto Airports Authority, Ottawa Airport Authority, Hamilton International Airport
- **Ground** – Private Motor Truck Council of Canada, Ontario Trucking Association, Canadian Union of Postal Workers, Ontario Stone Sand and Gravel, Supply Chain and Logistics Canada, Canadian Courier and Logistics Association, Canadian Industrial Transportation Association

## 7.2 Data References

### Chapter 1: Introduction

- Beagan, D., Fischer, M., & Kuppam, A. (2007). *Quick Response Freight Manual II*. Cambridge, MA: Cambridge Systematics Inc.
- Burks, S., Belzer, M., Kwan, Q., Pratt, S., & Shackelford, S. (2010). *Trucking 101: An Industry Primer*. Washington D.C.: Transportation Research Board.
- Cambridge Systematics; TransManagement; TransTech Management and Heanue, K. (2007). *Guidebook for Freight Policy, Planning, and Programming in Small- and Medium-Sized Metropolitan Areas*. Washington DC: Transportation Research Board.
- Greater Toronto Airport Authority. (2008). *The Airport Master Plan 2008-2030*. Toronto, ON.: Greater Toronto Airports Authority.
- Greenbaum, S. (2011, April 21). *Loading Dock*. Retrieved May 31, 2011, from Whole Building Design Guide; National Institute of Building Sciences: [http://www.wbdg.org/design/loading\\_dock.php](http://www.wbdg.org/design/loading_dock.php)
- Metrolinx. (2011). *GTHA Urban Freight Study (Final Draft)*. Toronto, ON.: Metrolinx.
- Ontario Ministry of Transportation. (2009). *Ontario Marine Transport Study – Phase 1 Final Report: Industry Profile and Economic Impact*. Toronto, ON.: Ontario Ministry of Transportation.
- Ontario Trucking Association. (2011). *Trucking Industry in Ontario*. Retrieved May 19, 2011, from Ontario Trucking Association: <http://www.ontruck.org/>
- Railway Association of Canada. (December 2010). *2011 Rail Trends*. Ottawa, ON.: Railway Association of Canada.
- Resor, R. R., & Blaze, J. R. (2004). Short-Haul Rail Intermodal: Can it Compete with Trucks? *Transportation Research Record: Journal of the Transportation Research Board (1873)*, 45-52.
- Statistics Canada. (December 2013). *Air Carrier Traffic at Canadian Airports 2012*. Ottawa, ON: Ministry of Industry.
- Statistics Canada. (2009). *Canada Year Book 2009*. Ottawa, ON.: Statistics Canada.
- Statistics Canada. (March 2012). *Shipping in Canada 2010*. Ottawa, ON: Ministry of Industry.
- Taylor, R., English, G., & Hackston, D. (2008). *Southern Ontario Gateway Transportation and Logistics Issues*. Hamilton, ON.: Research and Traffic Group; Southern Ontario Gateway Council.
- The Saint Lawrence Seaway Management Corporation. (2011). *The Seaway*. Retrieved May 10, 2011, from The Saint Lawrence Seaway Management Corporation: <http://www.greatlakes-seaway.com/en/index.html>
- Transport Canada. (2006). *Making Connections: Shortsea Shipping in Canada*. Ottawa, ON.: Transport Canada.
- Transport Canada. (2012). *Transportation in Canada 2011 Statistical Addendum*. Ottawa, ON.: Transport Canada.
- U.S. Transportation Research Board. (2004). *NCHRP Report 500: Guidance for Implementation of the AASHTO Strategic Highway Safety Plan - Volume 13: A Guide for Reducing Collisions Involving Heavy Trucks*. Washington, D.C.: U.S. Transportation Research Board.

## Chapter 2: Land Use and Transportation Planning Guidelines

- City of Hamilton, *City of Hamilton Truck Route Master Plan Study, Final Report*, April 2010, IBI Group
- City of Hamilton, *Waterdown/Aldershot Transportation Master Plan, Phase 2, Final Report*, February 2008. Dillion Consulting
- Delaware Department of Transportation (June 2004). "Delaware Freight and Goods Plan Technical Paper" Parsons. [http://www.deldot.gov/information/pubs\\_forms/freight\\_plan/pdf/technical\\_report.pdf](http://www.deldot.gov/information/pubs_forms/freight_plan/pdf/technical_report.pdf)
- iTrans (2004) *Goods Movement in Central Ontario: Trends and Issues*. Prepared for the MTO. December.
- Metrolinx. (2011). "GTHA Urban Freight Study (Final Draft)", Metrolinx.
- Ontario Ministry of Transportation, "Transit-Supportive Guidelines", 2012.
- Region of Waterloo, *Regional Transportation Master Plan, Moving Forward 2031*, January 2011, Region of Waterloo
- Toronto Pearson International Airport website. [www.torontopearson.com](http://www.torontopearson.com)
- Toronto Port Authority website. [www.torontoport.com](http://www.torontoport.com)
- Victoria Government of Australia (2009). "Green Triangle Freight Action Plan". [http://www.glenelg.vic.gov.au/files/Green\\_Triangle\\_Region\\_Freight\\_Action\\_Plan.pdf](http://www.glenelg.vic.gov.au/files/Green_Triangle_Region_Freight_Action_Plan.pdf)
- Wilbur Smith Associates and IBI Group. (2004). "Study of Goods Movement in Peel: Strategic Overview," Wilburn Smith Associates and IBI Group.

## Chapter 3: Site Plan Design Guidelines

- City of Toronto. (May 2008). *Guidelines for the Design and Management of Bicycle Parking Facilities*. Toronto: City of Toronto.
- Greenbaum, Sophia. (21 April 2011). "Loading Dock". *Whole Building Design Guide*. Accessed from [http://www.wbdg.org/design/loading\\_dock.php](http://www.wbdg.org/design/loading_dock.php) on 13 July 2011.
- Ontario Ministry of Municipal Affairs and Housing (OMMAH). (2011). *Ontario Building Code*. Toronto: OMMAH.
- Ontario Ministry of Transportation. (January 1994). *Commercial Site Access Policy and Standard Designs*. Toronto: Queen's Printer for Ontario.
- Ontario Ministry of Transportation (MTO). (March 1996). *Ontario Bikeways Planning and Design Guidelines*. Toronto: MTO.
- Pedestrian Safety Guide and Countermeasure Selection System. (2011). *Recommended Guidelines/Priorities for Sidewalks and Walkways*. Chapel Hill, North Carolina: Pedestrian and Bicycle Information Center.
- Transportation Association of Canada (TAC). (1999). *Geometric Design Guide for Canadian Roads*. Ottawa: TAC.

## Chapter 4: Operational Guidelines

- AASHTO. (2010). "Unlocking Freight – Transportation Reboot: Restarting America's Most Essential Operating System," AASHTO, Washington, DC.
- American Trade Initiatives. (2011). *Freeway Geometric Design for Active Traffic Management in Europe*. Washington, D.C.: U.S. Federal Highway Administration.
- Arizona Department of Transportation (2007). "Arizona Multimodal Freight Analysis Study," Arizona Department of Transportation. <http://azmemory.azlibrary.gov/cdm/ref/collection/statepubs/id/9338>
- Aron, M., Seidowsky, R., & Cohen, S. (2011). Safety Impact of Using the Hard Shoulder During Congested Traffic. The Case of a Managed Lane Operation on a French Urban Motorway. *Transportation Research Part C*, doi: 10.1016/j.trc.2010.12.006.
- Austrroads. (2002). *Geometric Design for Trucks - When, Where, and How?* Sydney, Australia: Austrroads.
- Battelle. (2010). NCFRP Report 7: *Identifying and using low-cost and quickly implementable ways to address freight-system mobility constraints*. Washington, D.C.: U.S. Transportation Research Board.
- Benekohal, R., & Zhao, W. (2000). Delay-Based Passenger Car Equivalents for Trucks at Signalized Intersections. *Transportation Research Part A*, 34 (6), 437-457.
- Cambridge Systematics. (2009). "FHWA Operations Support – Port Peak Pricing Program Evaluation," Federal Highway Administration, Washington, DC. <http://www.ops.fhwa.dot.gov/publications/fhwahop09014/fhwahop09014.pdf>
- Cambridge Systematics, Inc. (2003). *Intermodal Freight Connectors: Strategies for Improvement* (NCHRP Project 8-36, Task 30). U.S. Transportation Research Board, Washington, D.C.
- Canadian National Railway. Speed gate. <http://www.cn.ca/en/shipping-intermodal-terminals-speed-gate.htm> (accessed May 24, 2011).
- Caris, A., Macharis, C., & Janssens, G. (2010). Potential Benefits of Shipper Consolidation at Inland Distribution Centers. *Transportation Research Board 89th Annual Meeting*. Washington, D.C.: U.S. Transportation Research Board.
- Commercial Vehicle Safety Alliance. (2011, April). *Antilock Brake Systems (ABS) Inspections*. Retrieved May 12, 2011, from Inspection Bulletins: <http://www.cvs.org/>
- Delaware Valley Regional Planning Commission. (2010). *Freight Transportation: Municipal Implementation Tool #19*.
- Delaware Valley Regional Planning Commission. (2007). *National Highway System Connectors to Freight Facilities in the Delaware Valley Region*.
- Douglas, J. (2003). *NCHRP Synthesis 314: Strategies for Managing Increasing Truck Traffic*. U.S. Transportation Research Board, Washington, D.C.
- Duluth-Superior Metropolitan Interstate Committee. (2001). "Duluth-Superior Area Truck Route Study," Duluth, MN. [http://www.dsmic.org/documentstore/PlansandStudies\(Freight\)/2001/FINAL%20DOCUMENT-RW.pdf](http://www.dsmic.org/documentstore/PlansandStudies(Freight)/2001/FINAL%20DOCUMENT-RW.pdf)
- Eisele, W.L., Tardif, L-P, Villa, J.C., Shrank, D.L., and Lomax, T.J. (2011). "Developing and Applying Fluidity Performance Indicators in Canada to



- Evaluate International and Multimodal Freight System Efficiency,” Annual Meeting of the Transportation Research Board, Washington, DC.
- Ervin, R., Barnes, M., & Wolfe, A. (1985). *Liquid Cargo Shifting and the Stability of Cargo Tank Trucks: Executive Summary Report Volume 1*. Ann Arbor, MI: The University of Michigan Transportation Research Institute.
- Federal Highway Administration. (2010). *Access Management in the Vicinity of Intersections: Technical Summary*. Washington, D.C.
- Federal Highway Administration. (2010). *Mini-Roundabouts: Technical Summary*. Washington, D.C.
- Federal Highway Administration. (2010). *Roundabouts: Technical Summary*. Washington, D.C.
- Federal Highway Administration. (2009). “Urban Freight Case Studies: New York” Washington, DC. <http://www.ops.fhwa.dot.gov/publications/fhwahop10019/fhwahop10019.pdf>
- Federal Highway Administration. (2009). “Urban Freight Case Studies: Orlando,” Washington, DC. <http://www.ops.fhwa.dot.gov/publications/fhwahop10021/fhwahop10021.pdf>
- Federal Motor Carrier Safety Administration. (2007). *Highway/Heavy Vehicle Interaction: A Synthesis of Safety Practice*. Washington, D.C.
- Fitzpatrick, K., & Zimmerman, K. (2006). Potential Updates to the 2004 Green Book Acceleration Lengths for Entrance Terminals. Transportation Research Board 86th Annual Meeting. Washington, D.C.: U.S. Transportation Research Board.
- Frawley, W.E., Borowiec, J.D., Protopapas, A., Warner, J.E., and Morgan, C.A. (2010). “Guidebook on Landside Freight Access to Airports,” Texas Transportation Institute, College Station, TX. <http://tti.tamu.edu/documents/0-6265-P1.pdf>
- Furst, T. (2007, January/February). Freight with Urgency. *Public Roads*, 70 (4).
- Giuliano, G., Hayden, S., Dell’aquila, P., and O’Brien, T. (2008). “Evaluation of the Terminal Gate Appointment System at the Los Angeles/Long Beach Ports,” METTRANS Transportation Center.
- Giuliano, G. and O’Brien, T. (2008). “Responding to Increasing Port-Related Freight Volumes: Lessons from Los Angeles/Long Beach and Other U.S. Ports and Hinterlands,” Discussion Paper no. 2008-12, Joint Transport Research Centre, Organization for Economic Cooperation and Development and the International Transport Forum. <http://www.internationaltransportforum.org/jtrc/DiscussionPapers/DP200812.pdf>
- Giuliano, G., O’Brien, T., Clark, A., Linder, A., Rohmer, J., Tan, W., and Zhou, J. (2008). “Evaluation of Extended Gate Operations at the Ports of Los Angeles and Long Beach,” METTRANS Transportation Centre.
- Haldane, M., & Bunker, J. (2002). Examining the Impact of Large Freight Vehicles on Signalized Intersection Operation. AITPM National Conference. Perth, Australia.
- Harrison, R., Hutson, N., Prozzi, J., Gonzalez, J., McCray, J., and West, J. (2009). “The Impacts of Port, Rail, and Border Drayage Activity in Texas,” Texas Department of Transportation, Austin, TX. [http://www.utexas.edu/research/ctr/pdf\\_reports/0\\_5684\\_1.pdf](http://www.utexas.edu/research/ctr/pdf_reports/0_5684_1.pdf)
- Harwood, D. (1995). *NCHRP Report 375: Median Intersection Design*. Washington, D.C.: U.S. Transportation Research Board.

- Harwood, D., Potts, I., Torbic, D., & Glauz, W. (2003). *Commercial Truck and Bus Safety Synthesis Program*. Washington, D.C.: U.S. Transportation Research Board.
- Holguín-Veras, J., Ozbay, K., Kornhauser, A., Shorris, A., and Ukkusuri, S. (2010). "Integrative Freight Demand Management in the New York City Metropolitan Area," submitted to the U.S. Department of Transportation, Washington, DC. [http://www.transp.rpi.edu/~usdotp/DRAFT\\_FINAL\\_REPORT.pdf](http://www.transp.rpi.edu/~usdotp/DRAFT_FINAL_REPORT.pdf)
- Huynh, N.N. and Walton, C.M. (2005). "Methodologies for Reducing Truck Turn Time at Marine Container Terminals," Texas Transportation Institute, College Station, TX. <http://swuttc.tamu.edu/publications/technicalreports/167830-1.pdf>
- IBI Group. (2010). "City of Hamilton Truck Route Master Plan Study," IBI Group. <http://www.hamilton.ca/CityDepartments/PublicWorks/CommunityServicesRelatedPoliciesAndGuidelines/TruckRouteStudy.htm>
- Louis Berger Group, Inc. and A. Strauss-Weider, Inc. (2003). *NCHRP Report 497: Financing and Improving Land Access to U.S. Intermodal Cargo Hubs*. Washington, D.C.: U.S. Transportation Research Board.
- Kennedy, J. (2007). *International Comparison of Roundabout Design Guidelines*. Crowthorne, United Kingdom: Transport Research Laboratory.
- Kenny, B., Kwan, A., & Morrall, J. (2002). Design and Operational Considerations to Accommodate Long Combination Vehicles and Log Haul Trucks on Rural Highways in Alberta, Canada. *7th International Symposium on Heavy Vehicle Weights & Dimensions*, (pp. 231-240). Delft, The Netherlands.
- Kiewit Center for Infrastructure and Transportation. (2005). *Intersection Sight Design*. Salem, OR: Oregon Department of Transportation.
- Lipscomb, T. Long, S., and Grasman, S. (2011). "Sustainability Criteria for Inland Freight Hub Location Evaluation," Annual Meeting of the Transportation Research Board, Washington, DC.
- Liu, Q., & Garber, N. (2007). *Identifying the Impact of Truck-Lane Restriction Strategies on Traffic Flow and Safety Using Simulation*. University of Virginia, Center for Transportation Studies. Washington, D.C.: U.S. Department of Transportation.
- Mack-Blackwell Transportation Center. (2008). *Acceleration Lane Design for Higher Truck Volumes*. Washington, D.C.: U.S. Department of Transportation.
- Manitoba Transportation and Government Services (2005). "2020 – Manitoba Transportation Vision," Manitoba Transportation and Government Services, Winnipeg, MB. <http://www.gov.mb.ca/mit/2020/index.html>
- McMullen, B.S. (2010). "Multimodal Freight Investment Criteria," Oregon Department of Transportation, Salem, OR. [http://www.oregon.gov/ODOT/TD/TP\\_RES/docs/Reports/2010/Multimodal\\_Investment\\_Criteria.pdf?ga=t](http://www.oregon.gov/ODOT/TD/TP_RES/docs/Reports/2010/Multimodal_Investment_Criteria.pdf?ga=t)
- Metrolinx. (2011). "GTHA Urban Freight Study (Final Draft)," Metrolinx.
- National Association of Development Organizations Research Foundation. (2008). "Short Line Railroads: Saving an Endangered Species of Freight Transport," National Association of Development Organizations, Washington, DC.
- NCFRP. (2010). "Identifying and Using Low-Cost and Quickly Implementable Ways to Address Freight-System Mobility Constraints," Report 7, Transportation Research Board, Washington, DC. <http://>

- onlinepubs.trb.org/onlinepubs/nctfrp/nctfrp\_rpt\_007.pdf
- NCHRP. (2007). "Guidebook for Freight Policy, Planning, and Programming in Small- and Medium-Sized Metropolitan Areas," Report 570, Transportation Research Board, Washington, DC. [http://onlinepubs.trb.org/onlinepubs/nchrp/nchrp\\_rpt\\_570.pdf](http://onlinepubs.trb.org/onlinepubs/nchrp/nchrp_rpt_570.pdf)
- NCHRP. (2003). "Integrating Freight Facilities and Operations with Community Goals," Synthesis 320, Transportation Research Board, Washington, DC. [http://onlinepubs.trb.org/onlinepubs/nchrp/nchrp\\_syn\\_320.pdf](http://onlinepubs.trb.org/onlinepubs/nchrp/nchrp_syn_320.pdf)
- NCHRP. (2010). "Review of Canadian Experience with the Regulation of Large Commercial Motor Vehicles," Report 671, Transportation Research Board, Washington, DC. [http://onlinepubs.trb.org/onlinepubs/nchrp/nchrp\\_rpt\\_671.pdf](http://onlinepubs.trb.org/onlinepubs/nchrp/nchrp_rpt_671.pdf)
- Nebraska Transportation Center, Department of Civil Engineering. (2010). Acceleration Ramps Along High Operating Speed Roadways. Washington, D.C.: U.S. Department of Transportation.
- New Mexico Department of Transportation Research Bureau. (2007). "Establishing Freight Corridors," New Mexico Department of Transportation, Albuquerque, NM.
- New York City Department of Transportation. Truck routing. <http://www.nyc.gov/html/dot/html/motorist/truckrouting.shtml> (accessed May 12, 2011).
- New Zealand Transport Agency. (2000). *State Highway Geometric Design Manual*. Wellington, New Zealand.
- Ogden, K. (1991). Truck Movement and Access in Urban Areas. *Journal of Transportation Engineering*, 117 (1), 71-90.
- Ontario Ministry of Transportation. A guide to oversize/overweight vehicles and loads in Ontario. <http://www.mto.gov.on.ca/english/trucks/oversize/guide.shtml> (accessed May 18, 2011).
- Ontario Ministry of Transportation. The official MTO truck handbook. <http://www.mto.gov.on.ca/english/trucks/handbook/index.shtml> (accessed May 18, 2011).
- Opus Hamilton. (2008). "City of Prince George Dangerous Goods Route Study," Opus International Consultants. <http://princegeorge.ca/citybusiness/longrangeplanning/transportationplans/dangerousgoodsroute>
- Owens, N., Armstrong, A., Sullivan, P., Mitchell, C., Newton, D., Brewster, R., and Trego, T. (2010). *Traffic Incident Management Handbook*. U.S. Federal Highway Administration, Washington, D.C.
- Patmore, K., Rempel, G., Regehr, J., & Montufar, J. (2010). *Urban and Regional Transportation Emissions Modelling: Development of Spatial, Temporal, and Vehicle-Specific Factors for Manitoba*. Ottawa, ON: Environment Canada.
- PierPass. Offpeak information. <http://pierpass.org/offpeak-information/> (accessed May 12, 2011).
- Province of Ontario. Highway Traffic Act. <http://www.ontario.ca/laws/statute/90h08>
- Puget Sound Regional Council. (2010). *Transportation 2040 - Toward a Sustainable Transportation System Appendix J: Regional Freight Strategy*. Seattle, WA.
- Rempel, G., Baumgartner, T., & Montufar, J. (2011). A Methodology for Container Truck Traffic Data Collection for Inland Port Cities. *Transportation Research Record: Journal of the Transportation Research Board*, (in publication).

- SRF Consulting Group, Inc. (2002). *Access Operations Study: Intervening Access Analysis - Gaps*. St. Paul, MN: Minnesota Department of Transportation.
- Systems Technology, Inc. (2000). *The Capability and Enhancement of VDANL and TWOPAS for Analyzing Vehicle Performance on Upgrades and Downgrades Within IHSDM*. Washington, D.C.: U.S. Federal Highway Administration.
- Texas Transportation Institute. (2010). *Best Practices in Traffic Incident Management*. U.S. Federal Highway Administration, Washington, D.C.
- Texas Transportation Institute. (2003). *Truck Accommodation Design Guidance: Final Report*. Austin, TX: Texas Department of Transportation.
- Thompson, K.A., Bomba, M.A., Walton, C.M., and Botticello, J.E. (2006). "The Trans-Texas Corridor and the Texas Airport System: Opportunities and Challenges," Texas Department of Transportation, Austin, TX. [http://www.utexas.edu/research/ctr/pdf\\_reports/0\\_4644\\_1.pdf](http://www.utexas.edu/research/ctr/pdf_reports/0_4644_1.pdf)
- Transport Canada. (2008). "Estimates of the Full Cost of Transportation in Canada," Ottawa, ON.
- Transport Canada. (2006). "Making Connections: Shortsea Shipping in Canada," Transport Canada, Ottawa, ON. <http://www.tc.gc.ca/media/documents/policy/making-connections.pdf>
- Transportation Association of Canada. (2006). *Performance Measures for Road Networks: A Survey of Canadian Use*. Transport Canada, Ottawa, ON.
- Transportation Research Board. (2011). *NCFRP Report 10: Performance Measures for Freight Transportation*. Washington, D.C.
- Transportation Research Board. (2004). *NCHRP Report 500: Guidance for Implementation of the AASHTO Strategic Highway Safety Plan - Volume 13: A Guide for Reducing Collisions Involving Heavy Trucks*. Washington, D.C.: U.S. Transportation Research Board.
- Transportation Research Board. (2003). *NCHRP Report 505: Review of Truck Characteristics as Factors in Roadway Design*. Washington, D.C.
- Transportation Research Board. (2008). *NCHRP Report 600A: Human Factors Guidelines for Road Systems*. Washington, D.C.
- Transportation Research Board. (2003). *NCHRP Research Results Digest 275: Application of European 2+1 Roadway Designs*. Washington, D.C.
- Transportation Research Board. (1996). "Paying Our Way: Estimating Marginal Social Costs of Freight Transportation," Special Report 246, Washington, DC. <http://onlinepubs.trb.org/onlinepubs/sr/sr246.pdf>
- Tsao, H.-S. J. and Rizwan, A. (2000). "The Role of Intelligent Transportation Systems (ITS) in Intermodal Air Cargo Operations," Institute of Transportation Studies, University of California at Berkeley. <http://www.its.berkeley.edu/publications/UCB/2000/RR/UCB-ITS-RR-2000-5.pdf>
- U.S. Department of Transportation. (2000). *NHS Intermodal Freight Connectors: A Report to Congress*.
- The University of Michigan Transportation Research Institute. (1985). *Impact of Specific Geometric Features on Truck Operations and Safety at Interchanges*. Washington, D.C.: U.S. Federal Highway Administration.
- University of Michigan Transportation Research Institute. (1984). *NCHRP Report 270: Parameters Affecting Stopping*

*Sight Distance*. Washington, D.C.: U.S. Transportation Research Board.

University of Michigan Transportation Research Institute. (1985). *Side Friction for Superelevation on Horizontal Curves: Vol. II - Technical Report*. Washington, D.C.: U.S. Federal Highway Administration.

Valdali, S., Womack, K., & Pappu, M. (2009). Freight Route Decision Making in the Presence of Tolling - Evidence from Texas. *Transportation Research Board 88th Annual Meeting*. Washington, D.C.: U.S. Transportation Research Board.

Waddell, E., Gingrich, S. M., & Lenters, M. (2009). Trucks in Roundabouts: Pitfalls in Design and Operations. *Institute of Transportation Engineers Journal*, 40-45.

Wang, R., Wu, X. and Sivakumaran, K. (2010). "The Potential of Using Transit Infrastructure for Air Freight Movement: A Case Study in the Bay Area," Institute of Transportation Studies, University of California at Berkeley. <http://www.path.berkeley.edu/sites/default/files/publications/PRR-2010-38.pdf>

Weber, P., & Button, N. (2009). Accommodating Small and Large Users at Roundabouts. *2009 Annual Conference of the Transportation Association of Canada*. Vancouver, B.C.: Transportation Association of Canada.

Wilbur Smith Associates and IBI Group. (2004). "Study of Goods Movement in Peel: Strategic Overview," Wilbur Smith Associates and IBI Group. [http://www.peelregion.ca/planning/transportation/goods\\_mvmnt.htm](http://www.peelregion.ca/planning/transportation/goods_mvmnt.htm)

Zhou, L., Burriss, M., Baker, R., & Gieselbrecht, T. (2009). The Impact of Incentives on Toll Road Use by Trucks. *Transportation Research Board 88th Annual Meeting*. Washington, D.C.: U.S. Transportation Research Board.

## 7.3 Photo Credits

Pg	Photo Title	Source
<b>CHAPTER 1</b>		
5	<b>Figure 1.1:</b> Example of guideline features and navigation	MMM Group
7	<b>Figure 1.2:</b> Chocolate Production – Detailed Supply Chain View	Ministry of Transportation / MMM Group
7	<b>Figure 1.3:</b> Common Global Supply Chains for Ontario Products	Ministry of Transportation
11	<b>Figure 1.4:</b> Facilities that support freight movement in Ontario	MMM Group
12	<b>Table 1.1:</b> Truck classification scheme	MMM Group
13	<b>Figure 1.5:</b> CN Brampton Intermodal Terminal	Canadian National Railway. “Brampton, Ontario #EF-2956-23.” Online photograph <a href="http://www.cn.ca/en/media/media-kit/image-gallery">http://www.cn.ca/en/media/media-kit/image-gallery</a>
14	<b>Figure 1.6:</b> Port of Thunder Bay, Ontario	Port of Thunder Bay
15	<b>Figure 1.7:</b> The FedEx facility at Lester B. Pearson International Airport in Toronto	caribb. “FedEx Terminal.” October 30, 2008. Mississauga, Ontario. Online photograph <a href="http://www.flickr.com/photos/caribb/3011911090/">http://www.flickr.com/photos/caribb/3011911090/</a>
<b>CHAPTER 2</b>		
27	<b>Figure 2.1:</b> Freight nodes and corridors	Google (2011). <i>Google maps</i> . Retrieved from <a href="http://maps.google.ca">http://maps.google.ca</a> and MMM Group
27	<b>Figure 2.2:</b> New employment areas in one jurisdiction may require road improvements in another jurisdiction	Google (2011). <i>Google maps</i> . Retrieved from <a href="http://maps.google.ca">http://maps.google.ca</a> and MMM Group
30	<b>Figure 2.3:</b> Locating new employment areas	Google (2011). <i>Google maps</i> . Retrieved from <a href="http://maps.google.ca">http://maps.google.ca</a> and MMM Group
32	<b>Figure 2.4:</b> Stratifying uses to improve land use compatibility	Google (2011). <i>Google maps</i> . Retrieved from <a href="http://maps.google.ca">http://maps.google.ca</a> and MMM Group
32	<b>Figure 2.5:</b> Public transit stop in an employment area	MMM Group
32	<b>Figure 2.6:</b> Opportunities to reuse existing buildings	MMM Group

Pg	Photo Title	Source
32	<b>Figure 2.7:</b> Expansion into rural areas should be a last option	MMM Group
33	<b>Figure 2.8:</b> Port with a buffer area containing complementary uses	Google (2011). <i>Google maps</i> . Retrieved from <a href="http://maps.google.ca">http://maps.google.ca</a> and MMM Group
36	<b>Figure 2.9:</b> Traditional employment areas may not be located near highway access	Google (2011). <i>Google maps</i> . Retrieved from <a href="http://maps.google.ca">http://maps.google.ca</a> and MMM Group
36	<b>Figure 2.10:</b> An example of a complete Street	MMM Group
39	<b>Figure 2.11:</b> Flying J truck stop in Napanee, Ontario	Google (2011). <i>Google streetview</i> . Retrieved from <a href="http://maps.google.ca">http://maps.google.ca</a>
39	<b>Figure 2.12:</b> Typical road side rest area with washrooms and space for parking trucks	Google (2011). <i>Google streetview</i> . Retrieved from <a href="http://maps.google.ca">http://maps.google.ca</a>
41	<b>Figure 2.13:</b> Alternatives to addressing truck traffic that passes through a town's main street area	MMM Group
42	<b>Figure 2.14:</b> Truck supportive median options	Google (2011). <i>Google streetview</i> . Retrieved from <a href="http://maps.google.ca">http://maps.google.ca</a>
43	<b>Figure 2.15:</b> Near and far side bus stops	TCRP. <i>Near and Far Side Bus Stop Locations</i> . Retrieved from <a href="http://onlinepubs.trb.org/onlinepubs/tcrp/tcrp_rpt_19-b.pdf">http://onlinepubs.trb.org/onlinepubs/tcrp/tcrp_rpt_19-b.pdf</a>
43	<b>Figure 2.16:</b> Right-turn channelized lanes can make intersections unpleasant for pedestrians	Google (2011). <i>Google streetview</i> . Retrieved from <a href="http://maps.google.ca">http://maps.google.ca</a>
43	<b>Figure 2.17:</b> Street furniture along an arterial street	MMM Group
44	<b>Figure 2.18:</b> Idealized overlapping grids of truck routes/corridors and major transit lines	Google (2011). <i>Google maps</i> . Retrieved from <a href="http://maps.google.ca">http://maps.google.ca</a> and MMM Group
44	<b>Figure 2.19:</b> Grade-separated rail crossing	McCormick Rankin Corporation
45	<b>Figure 2.20:</b> Example of bicycle lane	Flickr.com-thelebers
46	<b>Figure 2.21:</b> Bicycle path options	MMM Group

Pg	Photo Title	Source
48	<b>Figure 2.22:</b> Freight route/corridor adjacent to an environmentally sensitive area	MMM Group
49	<b>Figure 2.23:</b> Rear lotting	MMM Group
50	<b>Figure 2.24:</b> Landscaped buffer with coniferous trees to assist in lowering the noise from the roadway from the employment area	Bing (2011). <i>Bing maps</i> . Retrieved from <a href="http://www.bing.com/maps/">http://www.bing.com/maps/</a>
50	<b>Figure 2.25:</b> Living wall	Google (2011). <i>Google streetview</i> . Retrieved from <a href="http://maps.google.ca">http://maps.google.ca</a>
50	<b>Figure 2.26:</b> Street-related development	MMM Group
51	<b>Figure 2.27:</b> Bilingual 'no engine brakes' traffic sign	Ghumplik, Flickr
51	<b>Figure 2.28:</b> Bioswale	Google (2011). <i>Google streetview</i> . Retrieved from <a href="http://maps.google.ca">http://maps.google.ca</a>
51	<b>Figure 2.29:</b> Roadside ditch	Google (2011). <i>Google streetview</i> . Retrieved from <a href="http://maps.google.ca">http://maps.google.ca</a>
51	<b>Figure 2.30:</b> Roadside berm	Google (2011). <i>Google streetview</i> . Retrieved from <a href="http://maps.google.ca">http://maps.google.ca</a>
51	<b>Figure 2.31:</b> A natural feature directly adjacent to the street with no ditch or bioswale present	Google (2011). <i>Google streetview</i> . Retrieved from <a href="http://maps.google.ca">http://maps.google.ca</a>
52	<b>Figure 2.32:</b> Amphibian crossing	MMM Group
52	<b>Figure 2.33:</b> Overhead animal crossing	Totten Sims Hubicki Associates
52	<b>Figure 2.34:</b> Animal crossing signs	Ministry of Transportation
53	<b>Figure 2.35:</b> Sharing the road	MMM Group
53	<b>Figure 2.36:</b> Aggregate/mining facility truck entrance	Google (2011). <i>Google streetview</i> . Retrieved from <a href="http://maps.google.ca">http://maps.google.ca</a>
54	<b>Figure 2.37:</b> Main Street deliveries	MMM Group
55	<b>Figure 2.38:</b> Rear delivery lane	Bing (2011). <i>Bing maps</i> . Retrieved from <a href="http://www.bing.com/maps/">http://www.bing.com/maps/</a>



Pg	Photo Title	Source
<b>CHAPTER 3</b>		
59	<b>Figure 3.1:</b> Examples of different types of sites	(From left to right) Example of an Office Land Use, July 5, 2011 Photograph taken by MMM Group;  Eatons Centre 4890832214_78806f1e01_bStrt2. Eaton Centre, Toronto. August 13, 2010 Toronto Ontario. Online photograph. <a href="http://www.flickr.com/photos/42956036@N03/4890832214/">http://www.flickr.com/photos/42956036@N03/4890832214/</a> ;  Example of Residential Land Use, July 5, 2011, Photograph taken by MMM Group  Kensington Market 3648503150_6f6a587279_b Laurenoostveen. Kensington Market. May 28, 2007 Toronto Ontario. Online photograph <a href="http://www.flickr.com/photos/laurieoostie/3648503150/">http://www.flickr.com/photos/laurieoostie/3648503150/</a> ;  St. Vincent's Hospital 888438774_923832566f_o Dugspr. St Vincent's Hospital 9. July 23 2007. Ottawa Ontario. Online photograph. <a href="http://www.flickr.com/photos/dugspr/888438774/">http://www.flickr.com/photos/dugspr/888438774/</a>
60	<b>Figure 3.2:</b> Truck entrance sign	Transportation Association for Canada (TAC). (1998). <i>Manual of Uniform Traffic Control Devices for Canada</i> . Ottawa: TAC.
60	<b>Figure 3.3:</b> Site arrangement for freight movement	MMM Group
62	<b>Figure 3.4:</b> Loading dock ramp	MMM Group
63	<b>Figure 3.5:</b> Example of loading dock design	MMM Group
65	<b>Figure 3.6:</b> Industrial site	Concert Properties Ltd. "9237-9283 Airport Road, Concert Realty Services – Brampton, ON." December 21, 2010 in Brampton, Ontario. Online photograph
66	<b>Figure 3.7:</b> Example of industrial site design	MMM Group
67	<b>Figure 3.8:</b> Example of rail-served industrial park site design	MMM Group
68	<b>Figure 3.9:</b> Office site with recessed loading dock	MMM Group
68	<b>Figure 3.10:</b> Landscaping utilized to screen loading area	MMM Group

Pg	Photo Title	Source
69	<b>Figure 3.11:</b> Appropriate use of wall screens	MMM Group
69	<b>Figure 3.12:</b> Loading docks separate from the parking areas	MMM Group
69	<b>Figure 3.13:</b> Signage used to direct deliveries to the designated areas	MMM Group
69	<b>Figure 3.14:</b> Example of office building site design	MMM Group
70	<b>Figure 3.15:</b> Appropriate screening	MMM Group
71	<b>Figure 3.16:</b> Example of big box retail	MMM Group
71	<b>Figure 3.17:</b> Separate access for trucks servicing a big box retail shopping centre	MMM Group
72	<b>Figure 3.18:</b> Appropriate screening	MMM Group
73	<b>Figure 3.19:</b> Shared loading dock facilities at a strip mall	MMM Group
74	<b>Figure 3.20:</b> A dedicated access for trucks	MMM Group
75	<b>Figure 3.21:</b> Example of residential site design	MMM Group
76	<b>Figure 3.22:</b> A hospital - example of an institutional site	York Central Hospital. "Hospital Photo." July 7, 2011. Online photograph <a href="http://yorkcentral.com/">http://yorkcentral.com/</a>
77	<b>Figure 3.23:</b> Example of institutional (hospital) site design	MMM Group
78	<b>Figure 3.24:</b> Truck turning on a narrow street	MMM Group
78	<b>Figure 3.25:</b> Example of site design in existing urban area	MMM Group
79	<b>Figure 3.26:</b> Designated on-street loading area	MMM Group
79	<b>Figure 3.27:</b> Back alley – alternative to on-street loading areas	MMM Group

Pg	Photo Title	Source
80	<b>Figure 3.28:</b> New mixed-use development containing a grocery store and residential units	MMM Group
81	<b>Figure 3.29:</b> Turning movements permitted across transit lanes in the median of a road	MMM Group
82	<b>Figure 3.30:</b> Clearly marked bike lane	Burden, Dan. Untitled photograph. 2006. Baldwin Park, California. Online photograph <a href="http://www.pedbikeimages.org/pubdetail.cfm?picid=1415">http://www.pedbikeimages.org/pubdetail.cfm?picid=1415</a>
84	<b>Figure 3.31:</b> Appropriate setbacks and sufficient sidewalk	MMM Group
85	<b>Figure 3.32:</b> Example of site design in rural industrial areas	MMM Group

#### CHAPTER 4

90	<b>Figure 4.1:</b> Acceleration lane on a major through corridor	MORR Transportation Consulting Ltd.
90	<b>Figure 4.2:</b> Pavement/shoulder extending beyond the end of the merge/acceleration lane	MORR Transportation Consulting Ltd.
91	<b>Figure 4.3:</b> Advance traffic signal warning flasher	MORR Transportation Consulting Ltd.
92	<b>Figure 4.4:</b> Lane narrowing on off-ramp	MMM Group & MORR Transportation Consulting Ltd.
94	<b>Figure 4.5:</b> Compound curve versus simple curve	MMM Group
94	<b>Figure 4.6:</b> Lateral obstructions that can impede trucks turning	Ogden, K. (1991). Truck Movement and Access in Urban Areas. <i>Journal of Transportation Engineering</i> , 117 (1), 71-90.
94	<b>Figure 4.7:</b> Turning template with swept path, off-tracking, and turning radius (side by side comparison of double trailer tractor and tractor semitrailer)	Transportation Association for Canada (TAC). (1998). <i>Manual of Uniform Traffic Control Devices for Canada</i> . Ottawa: TAC and MMM.

Pg	Photo Title	Source
95	<b>Figure 4.8:</b> Truck operating on reverse super-elevation and the rollover forces acting on the truck	MMM Group & MORR Transportation Consulting Ltd.
95	<b>Figure 4.9:</b> Truck rollover sign at a curve	Harwood, D., Potts, I., Torbic, D., & Glauz, W. (2003). <i>Commercial Truck and Bus Safety Synthesis Program</i> . Washington, D.C.: U.S. Transportation Research Board.
95	<b>Figure 4.10:</b> Placement of truck rollover sign and detection	Transportation Research Board. (2004). NCHRP Report 500: <i>Guidance for Implementation of the AASHTO Strategic Highway Safety Plan - Volume 13: A Guide for Reducing Collisions Involving Heavy Trucks</i> . Washington, D.C.: U.S. Transportation Research Board.
96	<b>Figure 4.11:</b> Plan view of storage lane length for left-turns	MMM Group & MORR Transportation Consulting Ltd.
96	<b>Figure 4.12:</b> Slotted left-turn	MORR Transportation Consulting Ltd.
98	<b>Figure 4.13:</b> Roundabout showing different turning treatments for trucks	MMM Group & MORR Transportation Consulting Ltd.
99	<b>Figure 4.14:</b> Roundabout cross-section (crowned - top left image; inward - top right image; outward - bottom images)	Waddell, E., Gingrich, S. M., & Lenters, M. (2009). Trucks in Roundabouts: Pitfalls in Design and Operations. <i>Institute of Transportation Engineers Journal</i> , 40-45.
100	<b>Figure 4.15:</b> Vehicle driving over centre island of mini roundabout	MORR Transportation Consulting Ltd.
102	<b>Figure 4.16:</b> Truck route map	City of Ottawa
103	<b>Figure 4.17:</b> Narrowed lanes and lanes that have been restriped to add capacity	MMM Group
104	<b>Figure 4.18:</b> Over-dimension warning signs	MORR Transportation Consulting Ltd.
105	<b>Figure 4.19:</b> Bridge weight rating sign	Transportation Association for Canada (TAC). (1998). <i>Manual of Uniform Traffic Control Devices for Canada</i> . Ottawa: TAC.
106	<b>Figure 4.20:</b> Alternative routing information displayed on a variable message sign	MORR Transportation Consulting Ltd.

Pg	Photo Title	Source
107	<b>Figure 4.21:</b> Truck blocking lanes while making a turn	MORR Transportation Consulting Ltd.
109	<b>Figure 4.22:</b> Climbing lane	MMM Group
110	<b>Figure 4.23:</b> Escape ramp	Sea turtle. "Runaway Truck Ramp." May 18, 2007. Online photograph <a href="http://www.flickr.com/photos/sea-turtle/899336843/">http://www.flickr.com/photos/sea-turtle/899336843/</a>
111	<b>Figure 4.24:</b> 2+1 roadway	MMM Group & MORR Transportation Consulting Ltd.
112	<b>Figure 4.25:</b> Sign showing the direction of the main highway	Transportation Association for Canada (TAC). (1998). <i>Manual of Uniform Traffic Control Devices for Canada</i> . Ottawa: TAC.
113	<b>Figure 4.26:</b> Cross-dock facility	MORR Transportation Consulting Ltd.
114	<b>Figure 4.27:</b> Intermodal container train	MORR Transportation Consulting Ltd.
116	<b>Figure 4.28:</b> Air cargo sign	MORR Transportation Consulting Ltd.
117	<b>Figure 4.29:</b> Municipal noise restriction	MORR Transportation Consulting Ltd.
119	<b>Figure 4.30:</b> Example truck route network map/schematic	City of Ottawa
119	<b>Figure 4.31:</b> Overheight when flashing	MORR Transportation Consulting Ltd.
120	<b>Figure 4.32:</b> Spring load restriction	MMM Group
121	<b>Figure 4.33:</b> Truck route sign	MORR Transportation Consulting Ltd.
121	<b>Figure 4.34:</b> Not a truck route	MORR Transportation Consulting Ltd.
121	<b>Figure 4.35:</b> Maximum width on bridge	MORR Transportation Consulting Ltd.
121	<b>Figure 4.36:</b> Carrier home-base and a chain of receivers	MMM Group & MORR Transportation Consulting Ltd.
122	<b>Figure 4.37:</b> Map showing a Hamilton to Duluth trip with four modal options	MMM Group & MORR Transportation Consulting Ltd.
123	<b>Figure 4.38:</b> Rail intermodal terminals	Canadian National Railways. "Montreal, Quebec EF-3071-103." Online photograph <a href="http://www.cn.ca/en/media/media-kit/image-gallery">http://www.cn.ca/en/media/media-kit/image-gallery</a>

Pg	Photo Title	Source
<b>CHAPTER 5</b>		
136	<b>Figure 5.1:</b> An example of the TRANSMAP interface, which allows users to identify available trucks, routes and costs associated with shipping freight	Accessed 6 March 2012 from <a href="http://www.trans.eu/en/transmaps.html">http://www.trans.eu/en/transmaps.html</a>
<b>CHAPTER 6</b>		
146	<b>Figure 6.1:</b> Trucking activity in the Region of Peel	MMM Group
147	<b>Figure 6.2:</b> Freight activity in the Delaware Valley	Courtesy of the Delaware Valley Regional Planning Authority
148	<b>Figure 6.3:</b> Norfolk International Airport, Virginia	Norfolk Airport Authority
150	<b>Figure 6.4:</b> Aerial view of Spartanburg, South Carolina	Flickr/SPAflyer
152	<b>Figure 6.5:</b> FAST Partnership informational brochure cover	FAST Partnership
154	<b>Figure 6.6:</b> Driver information sheet, Newton Abbot	Devon County Council
154	<b>Figure 6.7:</b> Loading bay in a densely developed small downtown in the United Kingdom	MMM Group
158	<b>Figure 6.8:</b> Alameda Corridor	Courtesy of the Alameda Corridor Transportation Authority
159	<b>Figure 6.9:</b> Shoppers Drug Mart	Courtesy Shoppers Drug Mart
161	<b>Figure 6.10:</b> Truck driver and bicyclist in the United Kingdom	MMM Group

# 8.0 GLOSSARY AND INDEX

---

This chapter contains a glossary and index of key terms and concepts.

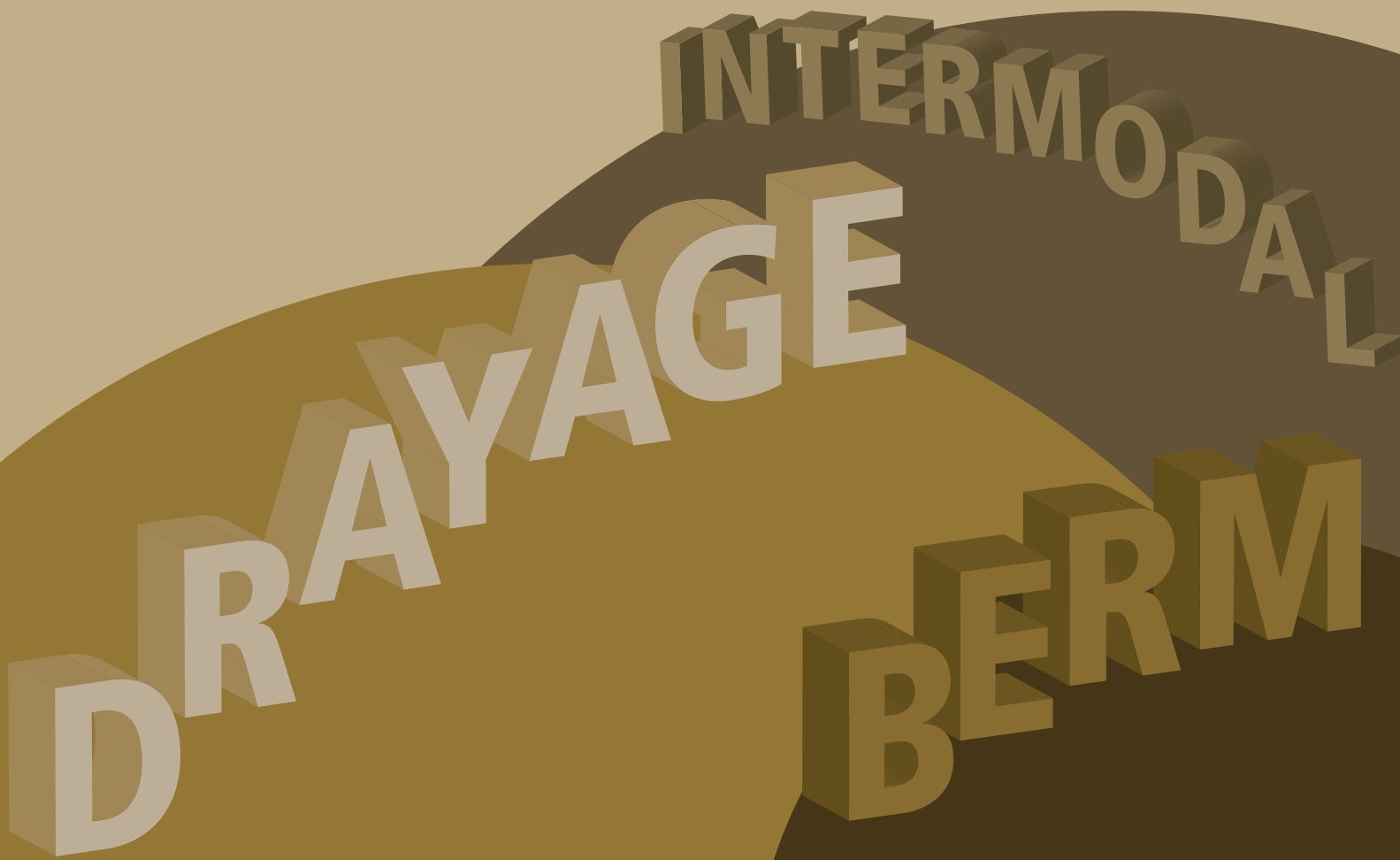





## 8.1 Glossary of Terms

**Active transportation:** human-powered travel, including but not limited to walking, cycling, inline skating and travel with the use of mobility aids, including motorised wheelchairs and other power-assisted devices moving at a comparable speed.

**Adjacent lands:** lands contiguous to existing or planned corridors and transportation facilities where development would have a negative impact on the corridor or facility. The extent of the adjacent lands may be recommended in guidelines developed by the Province or based on municipal approaches that achieve the same objectives.

**Berm:** a mound or bank of earth, used especially as a barrier.

**Big box retail:** retail stores with a large footprint and often surrounded by numerous parking spaces. Examples include home improvement stores, grocery stores and large retail shops.

**Building surface density:** constructing the outer walls of a building out of material that is designed to help lower or prevent the noise impacts of adjacent traffic on the building.

**Complete communities:** complete communities meet people's needs for daily living throughout an entire lifetime by providing convenient access to an appropriate mix of jobs, local services, a full range of housing, and community infrastructure including affordable housing, schools, recreation and open space for their residents. Convenient access to public transportation and options for safe, non-motorized travel is also provided.

**Complete streets:** streets planned to balance the needs of all road users, including trucks and service vehicles, pedestrians, cyclists, transit and motorists.

**Crime prevention through environmental design (CPTED):** multidisciplinary approach to deterring criminal behavior through the design of the built environment.

**Cross-dock facility:** distribution facility used for the transfer of traffic for rail or truck interchange. The facility is designed to transfer incoming shipments directly to outgoing trailers without storing them in between.

**Drayage:** the transportation of goods for a short distance. These short trips are often part of a longer overall move.

**Ecopassage:** overpass or underpass of a transportation facility that is designed to facilitate safe wildlife crossing from either side of the facility.

**Employment area:** those areas designated in an official plan for clusters of business and economic activities including, but not limited to, manufacturing, warehousing, offices, and associated retail and ancillary facilities.

**Freight audit:** a formal and comprehensive examination of the latent and existing demand, supply, and resources consumed, associated with the safe and efficient movement of freight in a region.

**Freight multimodal transportation system:** a transportation system that moves freight traffic between modes of transport to take advantage of the parcel size of each mode, e.g., small truck loads are gathered to form trainloads that are then transferred to ships.

**Freight-intensive land use:** land uses where the loading, unloading and storage of goods are the exclusive or dominant activities. Examples of such uses include *intermodal* terminals, distribution centres and warehouses.

**Freight-supportive:** in regard to land use patterns, means transportation systems and facilities that facilitate the movement of goods. This includes policies or programs intended to support efficient freight movement through the planning, design and operation of land use and transportation systems. Approaches may be recommended in guidelines developed by the Province or based on municipal approaches that achieve the same objectives.

**Harmonization:** to bring into agreement. In the case of the Freight-Supportive Guidelines, to ensure that regulations and by-laws are in agreement across municipal boundaries.

**Infill:** new development within existing communities on previously underutilized sites, typically at a higher density.

**Intelligent transportation systems (ITS):** the application of advanced technologies that improve the safety, security and efficiency of the transportation system.

**Intermodal:** movement of freight by two or more modes, typically by rail and truck or by ship and truck.

**Intermodal facility:** a location where transfers between modes can be made as part of a single journey. For example, a typical freight *intermodal facility* is a rail yard where containers are transferred between trucks and trains.

**Just-in-time delivery strategy:** approach where businesses limit the amount of inventory on hand and rely on freight services to deliver the goods that customers want when they want them.

**Load transfer ratio:** the extent to which a vertical load is transferred from the tires on one side of a vehicle to the other side. A load transfer ratio of 0 indicates that the load is balanced on the two sides.

**Logistics:** the process of planning, implementing, and controlling the efficient, cost effective flow and storage of raw materials, in-process inventory, finished goods and related information from point of origin to point of consumption for the purpose of meeting customer requirements.

**Long Combination Vehicle (LCV):** a tractor pulling two full-length semi-trailers up to 40 metres in overall length.

**Major facilities:** facilities which may require separation from *sensitive land uses*, including but not limited to airports, transportation infrastructure and corridors, *rail facilities*, *marine facilities*, sewage treatment facilities, *waste management systems*, oil and gas pipelines, industries, energy generation facilities and transmission systems, and resource extraction activities.

**Major goods movement facilities and corridors:** transportation facilities and corridors associated with the inter- and intra-provincial movement of goods. Examples include: *intermodal facilities*, ports, airports, *rail facilities*, truck terminals, freight corridors, freight facilities, and haul routes and primary transportation corridors used for the movement of goods.

**Marine facilities:** ferries, harbours, ports, ferry terminals, canals and associated uses, including designated lands for future *marine facilities*.

**Mixed-use development:** areas characterized by a wide variety of commercial, light industrial and residential uses. Mixed-use development may occur at the level of individual buildings or complexes or at a large-scale within activity nodes or corridors.

**Multimodal freight nodes:** points at which connections between transportation modes occur. Key examples include: highway-rail *intermodal facilities*, marine

ports, airports, freight hubs or villages, and transload facilities.

**Multimodal integration:** systems of interconnection between different transportation modes (such as air, marine, road and rail) in a transportation network so that the most appropriate modes of transportation can be used to move freight.

**Multimodal transportation:** the combination of two or more transportation modes for the movement of freight.

**Multimodal transportation system:** a transportation system which may include several forms of transportation such as automobiles, walking, trucks, cycling, buses, rapid transit, rail (such as commuter and freight), air and marine.

**Natural heritage features and areas:** features and areas, including *significant* wetlands, *significant* coastal wetlands, other coastal wetlands in Ecoregions 5E, 6E and 7E, fish habitat, *significant* woodlands and *significant* valleylands in Ecoregions 6E and 7E (excluding islands in Lake Huron and the St. Marys River), habitat of endangered species and threatened species, *significant* wildlife habitat, and *significant* areas of natural and scientific interest, which are important for their environmental and social values as a legacy of the natural landscapes of an area.

**Off-tracking:** the track that is taken by any trailer attached to a power unit. This path will occur within the turn radius of the power unit. Drivers must be aware of this so they can avoid hitting obstacles with the trailer.

**Passenger car equivalents (PCEs):** a metric used by transportation engineers to measure the impact that a mode of transportation has on traffic variables compared to a single car. (e.g. Private car = 1, Motorcycle = 0.5, Truck = 2.0)

**Pedestrian:** refers to all people on foot or moving at walking speed, including those who use mobility aids (wheelchairs, scooters, etc.), those with strollers and buggies and people with limited mobility.

**Planned corridors:** corridors or future corridors which are required to meet projected needs, and are identified through provincial plans, preferred alignment(s) determined through the Environmental Assessment Act process, or identified through planning studies where the Ontario Ministry of Transportation is actively pursuing the identification of a corridor. Approaches for the protection of *planned corridors* may be recommended in guidelines developed by the Province.

**Rail facilities:** rail corridors, rail sidings, train stations, *intermodal facilities*, rail yards and associated uses, including designated lands for future *rail facilities*.

**Rollover threshold:** the lowest value of centrifugal accelerations that will cause a truck to tip over when driving steadily in a curved path.

**Sensitive land uses:** buildings, amenity areas, or outdoor spaces where routine or normal activities occurring at reasonably expected times would experience one or more adverse effects from contaminant discharges generated by a nearby major facility. *Sensitive land uses* may be a part of the natural or built environment. Examples may include, but are not limited to: residences, day care centres, and educational and health facilities.

**Settlement areas:** urban areas and rural settlement areas within municipalities (such as cities, towns, villages and hamlets) that are:

- a) built up areas where development is concentrated and which have a mix of land uses; and

- b) lands which have been designated in an official plan for development over the long-term planning horizon. In cases where land in designated growth areas is not available, the settlement area may be no larger than the area where development is concentrated.

**Significant:**

- a) in regard to wetlands, coastal wetlands and areas of natural and scientific interest, an area identified as provincially significant by the Ontario Ministry of Natural Resources using evaluation procedures established by the Province, as amended from time to time;
- b) in regard to woodlands, an area which is ecologically important in terms of features such as species composition, age of trees and stand history; functionally important due to its contribution to the broader landscape because of its location, size or due to the amount of forest cover in the planning area; or economically important due to site quality, species composition, or past management history. These are to be identified using criteria established by the Ontario Ministry of Natural Resources.
- c) in regard to other features and areas, ecologically important in terms of features, functions, representation or amount, and contributing to the quality and diversity of an identifiable geographic area or natural heritage system;
- d) in regard to mineral potential, an area identified as provincially significant through evaluation procedures developed by the Province, as amended from time to time, such as the Provincially Significant Mineral Potential Index; and
- e) in regard to cultural heritage and archaeology, resources that have been determined to have cultural

heritage value or interest for the important contribution they make to our understanding of the history of a place, an event, or a people.

Criteria for determining significance for the resources identified in sections c) - e) are recommended by the Province, but municipal approaches that achieve or exceed the same objective may also be used.

While some significant resources may already be identified and inventoried by official sources, the significance of others can only be determined after evaluation.

**Super-elevation:** the practice of tilting a roadway to help offset centripetal forces that are developed as a vehicle goes around a curve.

**Swept path width:** the amount of road covered by a truck negotiating a turn. It is equal to the amount of off tracking plus the width of the tractor unit.

**Third-party logistics:** businesses that provide one or many of a variety of logistics-related services such as warehousing, transportation management, distribution management and freight consolidation.

**Transit-supportive:** development that makes transit viable and improves the quality of the experience of using transit. It often refers to compact, mixed-use development that has a high level of employment and residential densities. Approaches may be recommended in guidelines developed by the Province or based on municipal approaches that achieve the same objectives.

**Transload facility:** used for transferring shipments from truck to rail and vice versa.

**Transportation demand management:** a set of strategies that result in more efficient use of the *transportation system* by

influencing travel behaviour by mode, time of day, frequency, trip length, regulation, route, or cost.

**Transportation system:** a system consisting of facilities, corridors and rights-of-way for the movement of people and goods, and associated transportation facilities including transit stops and stations, sidewalks, cycle lanes, bus lanes, high occupancy vehicle lanes, *rail facilities*, parking facilities, park'n'ride lots, service centres, rest stops, vehicle inspection stations, *intermodal facilities*, harbours, airports, *marine facilities*, ferries, canals and associated facilities such as storage and maintenance.

**Truck routes/corridors:** roads designated, often through signage, as the permitted route for truck traffic. These designated roads link major truck origins and destinations and tend to avoid sensitive land uses. The roads may avoid sharp changes in elevation and may avoid other situations that hinder truck movement, such as narrow streets and may provide a bypass of downtown areas.

**Turnpike doubles (TPDs):** tractor-trailer combinations with two trailers. These are restricted to approved routes, the majority of which are on the provincial freeway system, based on engineering assessments and are permitted to access origins and destinations within about two (2) kilometers from the route, subject to municipal approval.

**Yaw:** to deviate temporarily from a straight course; a side to side movement.

## 8.2 Index

### A

---

#### Acceleration

Guideline 4.1, **89**; Guideline 4.1.1, **89**;  
Guideline 4.1.3, **93**; Guideline 4.1.5, **100**;  
Guideline 4.2.2, **107**; Section 5.4, **139**

#### Aggregate

Section 1.4.3.3, **14**; Guideline 2.1.4.1, **22**;  
Guideline 2.4.2, **53**; Guideline 3.10.1, **85**

#### Agriculture

Guideline 3.10.1, **85**; Section 6.2.1, **151**

#### Airports

Section 1.4.3, **10**; Section 1.4.3.1, **11**;  
Section 1.4.3.4, **15**; Section 1.5.4, **17**;  
Guideline 2.1.4.1, **22**; Guideline 2.1.6,  
**24**; Guideline 2.2.2, **27**; Guideline 2.2.3,  
**29**; Guideline 2.2.4, **30**; Guideline 2.2.5,  
**33**; Guideline 2.4.1, **48**; Section 5.4, **139**;  
Section 6.1.3, **148**; Section 6.1.4, **149**

### B

---

#### Box retail centres / strip malls

Guideline 3.4.4, **73**; Guideline 3.7.1, **78**

#### Buffers

Guideline 2.2.4, **30**; Guideline 2.3.6, **44**;  
Guideline 2.4.1, **48**; Guideline 3.1.4, **61**;  
Guideline 3.1.5, **64**; Guideline 3.4.1, **70**;  
Guideline 3.4.3, **72**; Guideline 3.10.1, **85**;  
Section 5.4, **139**

#### Building surface density

Guideline 2.4.1, **48**

#### By-laws

Section 1.4.1.3, **9**; Guideline 2.1.6, **24**;  
Guideline 2.1.7.1, **25**; Guideline 2.2.2, **27**;  
Guideline 3.1.4, **59**; Guideline 3.1.4, **61**;  
Guideline 3.8.1, **80**; Guideline 4.0, **87**;  
Guideline 4.4, **117**; Guideline 4.4.1, **117**;  
Guideline 4.4.4, **122**; Section 5.1, **127**;  
Section 5.1.2.1, **128**; Section 5.1.2.3, **130**;

Section 5.1.3, **130**; Section 5.1.4, **131**;  
Section 5.2.1, **132**; Section 5.4, **139**

### C

---

#### Community Improvement Plan

Guideline 3.7.1, **78**; Section 5.2.1, **132**

#### Crime Prevention through Environmental Design (CPTED)

Guideline 3.1, **59**; Guideline 3.1.1, **59**;  
Guideline 3.1.5, **64**; Guideline 3.4.3, **72**;  
Section 5.4, **139**

#### Cycling

Guideline 2.2.4, **30**; Guideline 2.3.1, **37**;  
Guideline 2.3.7, **45**; Guideline 3.7.1, **78**;  
Section 6.4.1, **161**

### D

---

#### D-Series Guidelines

Section 1.4.1.3, **9**; Guideline 2.3.6, **44**;  
Guideline 2.4.1, **48**

#### Deceleration

Guideline 2.4.1, **48**; Guideline 4.1.2, **91**;  
Guideline 4.1.5, **100**; Section 5.4, **139**

#### Demand management

Guideline 4.4.3, **121**; Section 5.1.2.1, **128**

#### Descending grades

Guideline 4.2.3, **109**

#### Divided highways

Guideline 4.2.2, **107**

### E

---

#### Ecopassages

Guideline 2.4.1, **48**

### F

---

#### Fire truck

Guideline 3.1, **59**; Guideline 3.1.3, **61**

**Freight audit**

Guideline 2.1, **21**; Guideline 2.1.1, **21**;  
 Guideline 2.1.2, **21**; Guideline 2.1.4.1, **22**;  
 Guideline 2.1.5.1, **23**; Guideline 2.1.6, **24**;  
 Guideline 2.1.7, **25**; Guideline 2.1.7.1,  
**25**; Guideline 2.2.1, **26**; Guideline 2.3.4,  
**40**; Guideline 4.1.6, **101**; Guideline 4.3.3,  
**114**; Guideline 4.3.4, **116**; Guideline 4.4.1,  
**117**; Guideline 4.4.4, **122**; Section 5.1.1,  
**127**; Section 5.1.2.2, **129**; Section 5.3.1,  
**137**; Section 5.3.2, **137**; Section 5.4, **139**;  
 Section 6.0, **143**; Section 6.1, **145**

**Freight Hubs**

Section 1.4.3.2, **13**; Guideline 2.2.5, **33**

**H****Harmonization**

Guideline 4.4.1, **117**; Section 5.1, **127**;  
 Section 5.3.1, **137**

**Highway Traffic Act**

Section 1.4.3.1, **11**

**Hospitals**

Section 1.3, **6**; Guideline 3.6.1, **76**

**I****Intermodal facilities**

Guideline 2.2.2, **27**; Guideline 2.2.5, **33**;  
 Guideline 2.3.6, **44**; Guideline 4.1.6, **101**;  
 Guideline 4.3, **112**; Guideline 4.3.1, **112**;  
 Guideline 4.3.2, **113**; Section 6.1.2, **147**;  
 Section 6.4.2, **162**

**J****Just-in-time delivery**

Section 1.4.2, **9**; Guideline 2.2.2, **27**;  
 Guideline 4.3.2, **113**

**L****Long Combination Vehicles**

Guideline 2.2.3, **29**; Guideline 4.1.1, **89**;  
 Guideline 4.1.3, **93**; Guideline 4.1.4, **97**

**M****Marine ports**

Section 1.5.4, **16**; Guideline 2.1.4.1, **22**;  
 Guideline 2.2.4, **30**; Guideline 2.2.5, **33**;

**Marine facilities**

Guideline 2.2.3, **29**; Guideline 2.2.5, **33**;  
 Guideline 4.3.3, **114**

**Mining**

Section 1.3.1, **6**; Guideline 2.4.2, **53**;  
 Guideline 3.0, **57**; Guideline 3.10.1, **85**

**Multimodal freight system**

Guideline 2.2.5, **33**; Section 6.1.3, **148**

**Municipal Act**

Section 5.1.3, **130**; Section 5.3.4, **138**

**P****Planning Act**

Section 1.4.1, **8**; Section 5.1.2, **128**;  
 Section 5.1.2.1, **128**; Section 5.2.1, **132**;  
 Section 5.2.2, **132**

**Q****Quarries**

Guideline 2.2.3, **29**; Guideline 2.4.2, **53**;  
 Guideline 3.0, **57**; Guideline 3.10.1, **85**;  
 Guideline 4.2.1, **103**

**R****Railway Safety Act**

Section 1.4.3.2, **13**

**Regulations**

Section 1.4.1.3, **9**; Guideline 2.1.1, **21**;  
 Guideline 2.1.4.1, **22**; Guideline 2.1.6, **24**;  
 Guideline 4.2.3, **109**; Guideline 4.4.1, **117**;  
 Guideline 4.4.3, **121**; Section 5.1.1, **127**;  
 Section 5.1.2, **128**; Section 5.1.2.1, **128**;  
 Section 5.1.2.3, **130**; Section 5.1.3, **130**

**Rest areas**

Guideline 2.3.3, **39**; Guideline 4.4.2, **118**

### **Restaurants**

Guideline 3.0, **57**; Guideline 3.3.1, **68**;  
Guideline 3.4.1, **70**; Guideline 3.4.2, **71**;  
Guideline 3.4.4, **73**; Section 6.3.2, **160**

### **Roundabouts**

Guideline 4.1.4, **97**; Section 5.4, **139**

### **Rural areas**

Guideline 2.2.4, **30**; Guideline 2.3.7, **45**;  
Guideline 2.4.2, **53**; Guideline 3.4.1, **70**;  
Guideline 3.10.1, **85**

## **S**

---

### **Schools**

Section 1.3, **6**; Guideline 2.2.1, **26**;  
Guideline 3.6.1, **76**

### **Sensitive land uses**

Section 1.3, **6**; Guideline 2.2.4, **30**;  
Guideline 2.2.5, **33**; Guideline 2.3.1, **37**;  
Guideline 2.3.5, **40**; Guideline 2.4.1, **48**;  
Guideline 2.4.2, **53**; Guideline 3.2.1, **65**;  
Guideline 3.4.3, **72**; Guideline 3.8.1, **80**;  
Guideline 3.10.1, **85**; Guideline 4.4.2, **118**

### **Setbacks**

Guideline 2.2.1, **26**; Guideline 2.2.4, **30**;  
Guideline 2.3.5, **40**; Guideline 2.3.6, **44**;  
Guideline 2.4.1, **48**; Guideline 3.8.1, **80**

### **Shopping malls**

Guideline 3.4.3, **72**; Section 6.3.1, **159**

### **Site access**

Section 1.5.2, **16**; Guideline 3.1, **59**;  
Guideline 3.1.2, **59**; Guideline 3.1.3, **61**;  
Section 5.4, **139**

### **Site plan control**

Guideline 2.4.1, **48**; Section 5.1.2.1, **128**;  
Section 5.2.2, **132**

### **Sound barrier walls**

Guideline 2.4.1, **48**

## **T**

---

### **Transload facilities**

Guideline 4.3.2, **113**

### **Travel time**

Section 1.5.3, **16**; Guideline 2.3.5, **40**;  
Guideline 2.3.5, **40**; Guideline 4.2.1, **103**;  
Guideline 4.3.4, **116**; Guideline 4.4.2, **118**;  
Guideline 4.4.3, **121**; Section 5.2.5, **134**;  
Section 6.2.7, **158**

### **Truck stability**

Guideline 4.1.3, **93**; Guideline 4.1.4, **97**

### **Turning movements**

Guideline 2.3.5, **40**; Guideline 2.4.3, **54**;  
Guideline 3.9.1, **81**; Guideline 3.9.3, **83**;  
Guideline 4.1.3, **93**; Guideline 4.1.4, **97**

## **U**

---

### **Urban areas**

Section 1.4.2, **9**; Guideline 2.2.6, **34**;  
Guideline 2.4.3, **54**; Guideline 3.0, **57**;  
Guideline 3.2.1, **65**; Guideline 3.7.1, **78**;  
Guideline 4.4.3, **121**





